



# MARCH PUMPS

1819 PICKWICK AVE., GLENVIEW, IL 60026-1306, U.S.A  
PHONE: (847) 729-5300 - FAX: (847) 729-7062  
WWW.MARCHPUMP.COM

## INSTRUCTIONS & REPAIR PARTS FOR MODEL AC-5C-MD PUMP



MODEL AC-5C-MD  
ASS'Y. NO. 0150-0026-0100

MODEL NO.	CONNECTORS		ELECTRICAL			G.P.M. AT LISTED HEAD						PSI GAGE	DIMENSIONS			PACK WT.
	INLET	OUTLET	HP	WATTS	AMPS	1 FT.	3 FT.	6 FT.	12 FT.	18 FT.	24 FT.		HT.	WD.	LG.	
AC-5C-MD	1" FPT	1/2" MPT	1/8	227	2.2	18	16.3	15	12.5	9.5	4.2	11.2	6-3/16"	4-1/2"	9-1/8"	14 LBS.

### PUMP CONSTRUCTION & SERVICING

March "Orbital" Magnetic Drive Pumps eliminate the conventional shaft seals found in most pumps. This means that there is no rotating seal to wear and allow the liquid being pumped to leak out. The pumping action may eventually fail, however the liquid can never leak out. The Model AC-5C-MD has an open air fan cooled, moisture protected motor, allowing the pumps to be run continuously.

All pumps can be serviced with the use of a screwdriver. The only moving part in the pump, other than the motor, is the impeller-magnet assembly. This assembly rotates on a stationary spindle and up against a thrust washer. These are the only parts that can wear, and may need to be replaced. See the Repair Parts List for replacement parts.

### ELECTRICAL CONNECTIONS AND RUNNING DRY

All models are standard with 115 volt, 50/60 cycle, 1 phase, A.C. motor. The motors are thermal overload protected, and the motor and overload combinations are U.L. and C.S.A. listed. All cord sets are U.L. approved 18/3 wire, SJO or SJT cords. The AC style pumps have 3 foot long cords with no plug attached.

We rely on the liquid being pumped to lubricate the impeller-magnet assembly spinning on the stationary spindle. The pump is not to run dry as the plastic may "freeze" onto the spindle. Teflon, and Carbon bushings are available if needed for dry run protection. Contact the factory for special applications.

### PUMP MATERIALS

All screws are type 18-8 stainless.  
All "O" ring gaskets are Buna-N rubber.  
All stationary spindles are ceramic.  
All wetted plastic parts are Glass Filled Polypropylene plastic.  
Motor Bracket is Glass Filled Polypropylene.  
The thrust washer is ceramic.  
Other materials are available, contact the factory for other than standard parts.

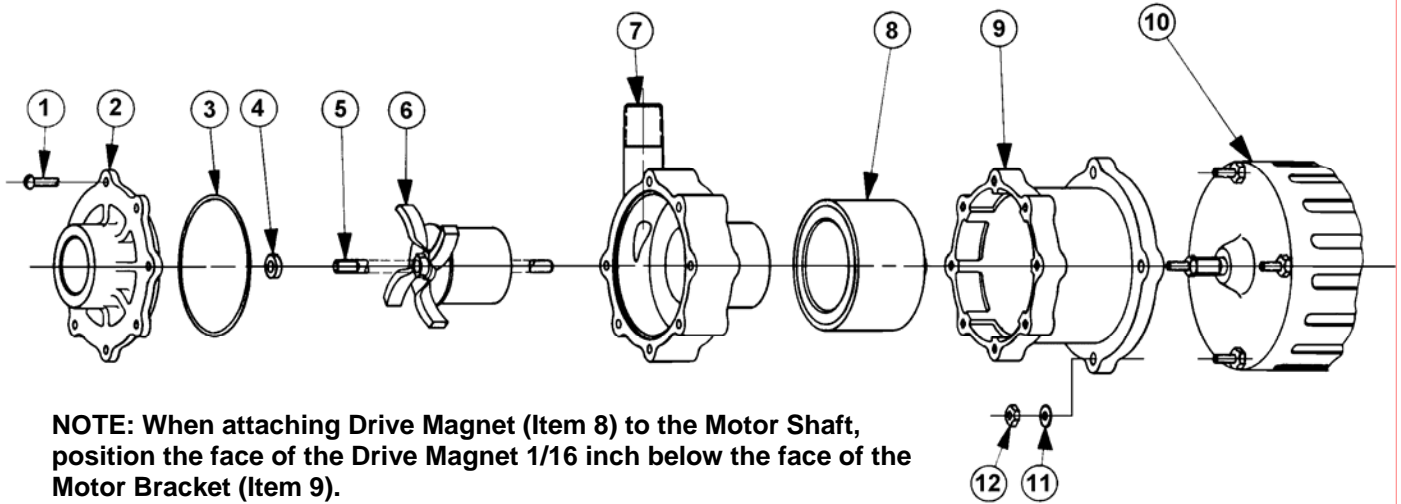

MODEL AC-5C-MD REPAIR PARTS LIST			
ITEM	DESCRIPTION	QTY.	PART NO.
1	#8 x 1¾ Long Screws	7	0150-0021-1000
2	Cover	1	0150-0032-1000
3	"O" Ring, Buna-N	1	0135-0007-1000
3A	"O" Ring, Viton	1	0135-0023-1000
4	Ceramic Thrust Washer	1	0130-0028-1000
5	Spindle	1	0130-0024-1000
6	Impeller-Magnet Ass'y.	1	0150-0030-0100
6A	Impeller-Magnet Ass'y with Stainless Cover	1	0150-0030-0200
7	Pump Housing	1	0150-0031-0100
8	Drive Magnet Ass'y.	1	0150-0081-0100
9	Motor Bracket	1	0150-0070-0100
10	Motor, 115 Volt	1	0150-0027-1000
11	Bracket Washer	4	0802-0006-1000
12	Bracket Nuts	4	0625-0024-1000

Contact factory for other materials and/or parts not listed.

### LIMITED WARRANTY

March pumps are guaranteed only against defects in workmanship or materials for a period of one year from date of manufacture pumping water. On all other solutions, contact the factory for application assistance. March Pump Application Worksheet 750-130-10 is available for additional warranty information.