



MARCH PUMPS

1819 PICKWICK AVE., GLENVIEW, IL 60026-1306, U.S.A
 PHONE: (847) 729-5300 - FAX: (847) 729-7062
 WWW.MARCHPUMP.COM

INSTRUCTIONS & REPAIR PARTS FOR MODEL AB-2F CONDENSATE DISPOSAL PUMP

LOCATION: Model AB-2F pump is designed to mount BELOW the evaporator pan. It is preferable to mount pump as close to drip pan drain as possible to minimize actual lift and to clear components usually found on floor of most A.C. units. Pump is designed to mount on side of A.C. unit, or on wall near unit by using the two ears on each end of the red plastic sump.



SERVICING AND MAINTENANCE:

Remove the 6 screws on each corner of the galvanized sump cover and lift the assembly out of the Red Sump container. Clean out all dirt accumulation on the parts. Check the float rods to be sure they work freely. Check the discharge fitting and tubing for any dirt accumulation. Place the sump cover back in place and screw down with the 6 screws. Run the unit thru one cycle by pouring water into the container. Always replace the white top cover.

ELECTRICAL AND OPERATION: Remove the 2 self tapping screws holding down the White Top Cover and lift the cover off. The Model AB-2F pump is equipped with a BX Bracket and a 5 station Terminal Board. The complete wiring diagram is attached to the inside of the White Top Cover. Attach rigid or flexible conduit to the BX Bracket and wire the 115 Volt A.C. line for the Control On-Off Switch per the wiring diagram. The 115 volt line current will operate the Motor-Pump-Float combination.

The Safety Switch must be connected to the 24 Volt A.C. relay transformer to the Air Conditioning Thermostat. If the Pump should fail to operate for any reason, the water will eventually trip the Safety Float and cause the Air Conditioning unit to shut off. This will prevent additional water from collecting and overflowing the container.

The motor is also available in 230 Volt, 60 Cycle, 1 Phase. All motors are equipped with an automatic reset type thermal protector and the combination is U.L. listed.

PIPING: The Condensate Pump Inlet is a 1" diameter hole in the rubber grommet in the top metal plate. Attach a 1" O.D. rubber or plastic tube to the evaporator drip pan drain connection, and lead it down into the pump inlet hole. Make sure the drain line is not kinked or collapsed due to sharp bends.

The Outlet fitting is a 90° tube fitting to which you attach the 1/4" I.D. plastic tubing. It is important to go straight up from the pump to the highest vertical point and then run the horizontal line to the drain. All horizontal lines should be slanted slightly downward toward the drain or disposal area in order to prevent line drain-back into the pump after it goes off (See Figure 1). If impractical to slant the horizontal run, make an inverted "U" trap directly over the pump at the highest point to prevent back-syphoning (See Figure 2). The slight amount of drain-back from vertical column is not generally enough with 1/4" I.D. tubing to short-cycle the pump. Total maximum lift is 17 feet.

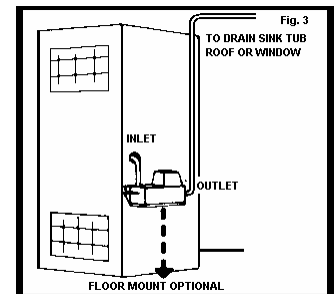
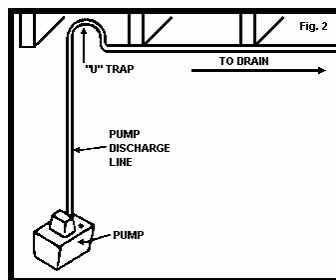
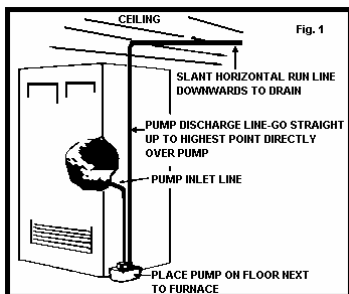

MODEL AB-2F RATINGS & SPECIFICATIONS

MOTOR SPECS.					GALLONS PER HOUR (Ratings based on using 1/4" I.D. tubing)				MAX. HEAD IN FT.	MAX. P.S.I.	OUTLET PORT	PACKED WEIGHT
VOLTS	AMPS	WATTS	H.P.	R.P.M	1 FT.	5 FT.	10 FT.	15 FT.				
115	1.7	88	1/35	3000	75	55	29	7	17	7.4	1/4" F.P.T.	6 lbs.

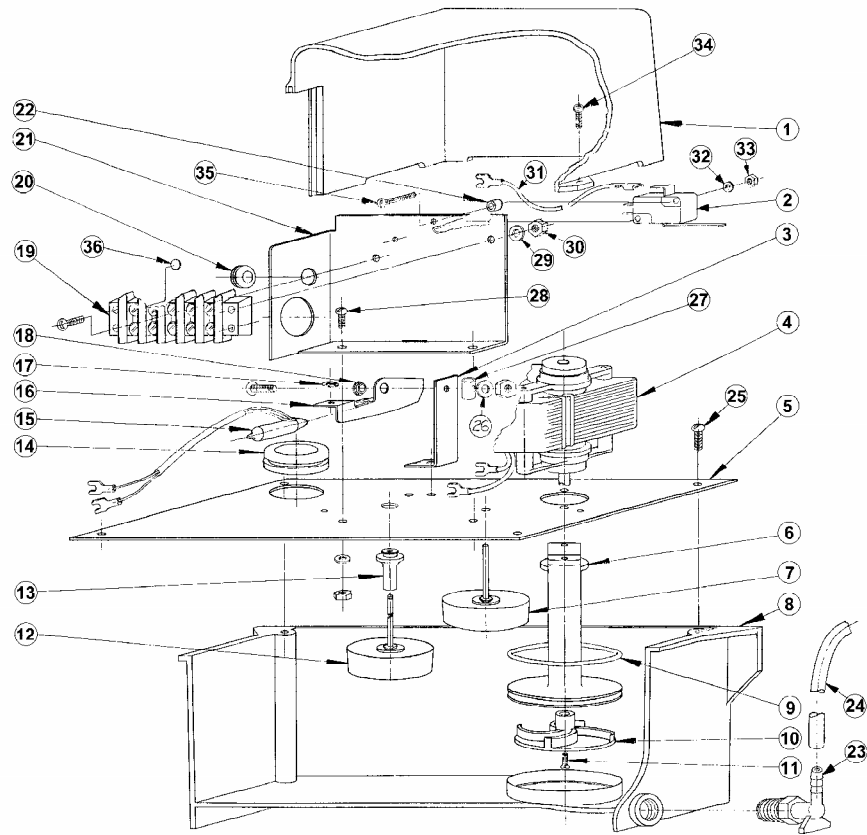

MODEL AB-2F — PARTS LIST

ITEM	DESCRIPTION	QTY.	PT. NO.	ITEM	DESCRIPTION	QTY.	PT. NO.
1	Pump Cover	1	0618-0002-1000	19	#5 Terminal Strip	1	0415-0012-1000
2	Safety Switch	1	0415-0026-1000	20	Grommet	1	0618-0032-1000
3	Mercury Switch Bracket	1	0618-0012-1000	21	Term. & Switch Mtg. Plate	1	0618-0008-1000
4	Motor – 115 Volt – 60 Cycle	1	0618-0001-1000	22	Switch Spacer	2	0618-0020-1000
5	Pump Mounting Plate	1	0618-0007-1000	23	90° Elbow	1	0618-0033-1000
6	Pump Connecting Body	1	0618-0014-1000	24	¼" I.D. X 20 Ft. Lg. Tubing	1	0410-0024-1000
7	Safety Float Rod Assem.	1	0618-0009-0100	25	#8-32 X ½" Lg. Screw	6	0410-0078-1000
8	Pump Bottom Case	1	0618-0003-1000	26	Pivot Washer	1	0410-0009-1000
9	"O" Ring	1	0618-0031-1000	27	Wire Clamp	1	0620-0023-0000
10	Impeller	1	0618-0005-1000	28	#8-32 X 3/8" Lg. Rd. Hd. Screw	5	0135-0040-1000
11	#4-40 Bass Screw	1	0618-0025-1000	29	#8 Internal Tooth Lock Washer	9	0620-0010-1000
12	Float Rod Assembly	1	0618-0010-0100	30	#8-32 Hex Nut	9	0410-0039-1000
13	Float Rod Guide	1	0618-0006-1000	31	Connecting Wire & Terminal Assy.	2	0618-0021-0100
14	Grommet	1	0618-0017-1000	32	#4-40 Lock Washer	2	0410-0034-1000
15	Mercury Switch & # 6 Terminal Assy.	1	0620-0024-0100	33	#4-40 Hex Nut	2	0618-0024-1000
16	Mercury Switch Lever Holder	1	0410-0022-1000	34	#6 Self-Tapping Screw	2	0620-0022-1000
17	Float "E" Ring	3	0410-0007-1000	35	#4-40 X ¾" Lg. Rd. Hd. Screw	2	0618-0026-1000
18	Switch Bushing	1	0620-0025-1000	36	Switch Screw Insulator	1	0618-0034-1000

Contact factory for other materials and/or parts not listed.

LIMITED WARRANTY

March pumps are guaranteed only against defects in workmanship or materials for a period of one year from date of manufacture pumping water. See March limited warranty statement on card #0410-0104-1000 packed with this pump.



1819 PICKWICK AVE., GLENVIEW, IL 60026-1306, U.S.A
 PHONE: (847) 729-5300 · FAX: (847) 729-7062 · www.marchpump.com

0618-0038-1000 R9