



MARCH PUMPS

1819 PICKWICK AVE., GLENVIEW, IL 60026-1306, U.S.A
 PHONE: (847) 729-5300 - FAX: (847) 729-7062
 WWW.MARCHPUMP.COM

INSTRUCTIONS & REPAIR PARTS FOR MODEL AB-1F CONDENSATE DISPOSAL PUMP



MODEL AB-1F RATINGS & SPECIFICATIONS

MOTOR SPECS.					GALLONS PER HOUR (Rating based on using 1/4" I.D. Tubing)				MAX HEAD IN FT.	MAX P.S.I	OUTLET PORT	PACKED WEIGHT
VOLTS	AMPS	WATTS	H.P.	R.P.M.	1 FT.	5 FT.	10 FT.	15 FT.				
115	1.55	88	1/35	3300	75	55	29	7	17	7.4	1/4 F.P.T	6 lbs.

LOCATION: Model AB-1F pump is designed to mount BELOW the evaporator pan. It is preferable to mount pump as close to drip pan drain as possible to minimize actual lift and to clear components usually found on floor of most A.C. units. Pump is designed to mount on side of A.C. unit or on wall near unit by using the two ears on each end of the red plastic sump.

PIPING: The Condensate Pump Inlet is a 1" diameter hole in the rubber grommet in the top metal plate. Attach a 1" O.D. rubber or plastic tube to the evaporator drip pan drain connection and lead it down into the pump inlet hole. Make sure the drain line is not kinked or collapsed due to sharp bends.

The Outlet is a 90° tube fitting to which you attach the 1/4" I.D. plastic tubing. It is important to go straight up from the pump to your highest vertical point and then run the horizontal line to the drain. All horizontal lines should be slanted slightly downwards toward the drain or disposal area in order to prevent line drain-back into the pump after it goes off See (Figure 1). If impractical to slant the horizontal run, make an inverted "U" trap directly over the pump at the highest point to prevent back-syphoning (See Figure 2). The slight amount of drain-back from vertical column is not generally enough with 1/4" I.D. tubing to short-cycle the pump. Total maximum lift is 17 feet.

ELECTRICAL AND OPERATION: Remove the 2 self-tapping screws holding down the White Top Cover and lift the cover off. The Model AB-1F pump is equipped with a BX BRACKET and a 3 station Terminal Board. The complete wiring diagram is attached to the inside of the White Top Cover. Attach rigid or flexible conduit to the BX Bracket and wire the 115 Volt A.C. line for the Control On-Off Switch per the wiring diagram. The 115 Volt line current will operate the Motor-Pump-Float combination.

The motor is available in 230 Volt, 60 Cycle, 1 Phase. All motors are equipped with an automatic reset type thermal protector and the combination is U.L listed.

SERVICING AND MAINTENANCE: Remove the six screws on each corner of the galvanized sump cover and lift the assembly out of the Red Sump container. Clean out all dirt accumulation on the parts. Check the float rods to be sure they work freely. Check the discharge fitting and tubing for any dirt accumulation. Place the sump cover back in place and screw down with the 6 screws. Run the unit thru one cycle by pouring water into the container. Always replace the white top cover.

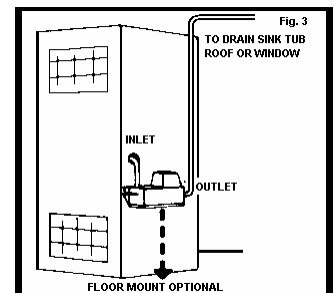
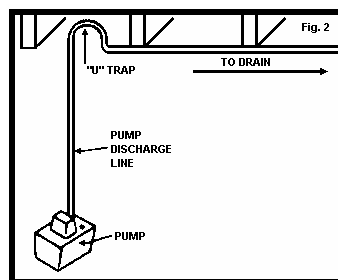
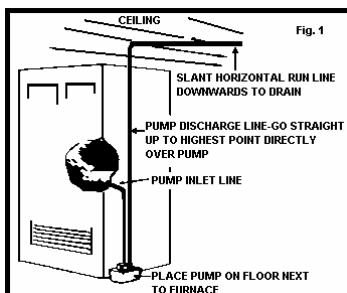

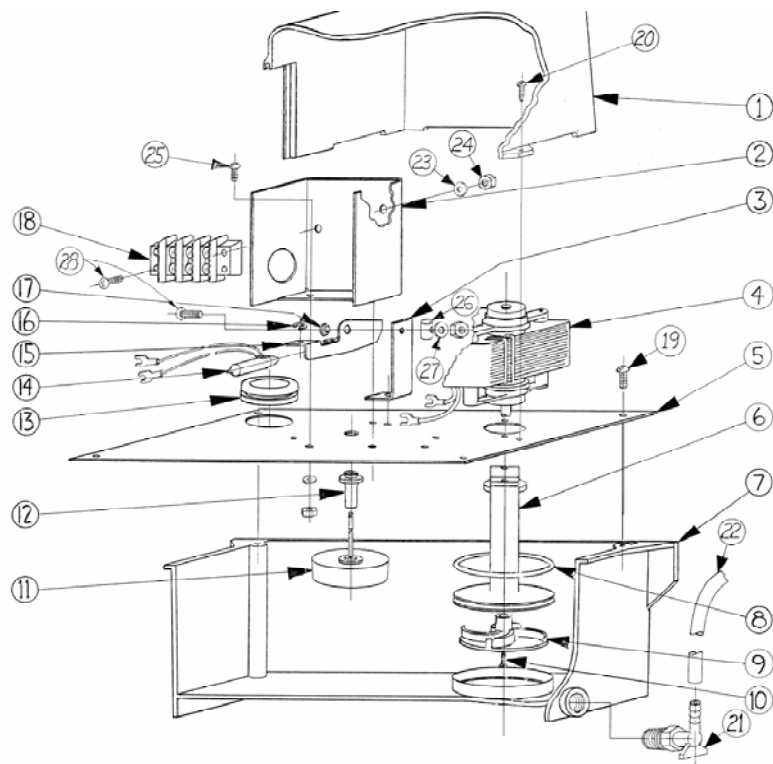

MODEL AB-1F PARTS LIST

ITEM	DESCRIPTION	QUANTITY	PART NUMBER
1	Pump Cover	1	0618-0002-1000
2	Term. & Switch Mtg. Plate	1	0618-0046-1000
3	Mercury Switch Bracket	1	0618-0012-1000
4	Motor 115V-60 Cycle	1	0618-0001-1000
5	Pump Mounting Plate	1	0618-0007-1000
6	Pump Connecting Body	1	0618-0014-1000
7	Pump Bottom Case	1	0618-0003-1000
8	"O" Ring	1	0618-0031-1000
9	Impeller	1	0618-0005-1000
10	#4-40 Brass Screw	1	0618-0025-1000
11	Float Rod Assembly	1	0618-0022-1000
12	Float Rod Guide	1	0618-0006-1000
13	Grommet	1	0618-0017-1000
14	Mercury Switch & #6 Terminal Ass'y.	1	0620-0024-0100
15	Mercury Switch Lever Holder	1	0410-0022-1000
16	Float "E" Ring	2	0410-0007-1000
17	Switch Bushing	1	0620-0025-1000
18	3-Terminal Board	1	0618-0074-1000
19	#8 x 1/2" Lg. Self Tap Screw	6	0410-0078-1000
20	#6 Screw-Self Tapping	2	0620-0022-1000
21	90° Elbow	1	0618-0033-1000
22	1/4" I.D. Tubing x 20 Ft. Long	1	0410-0024-1000
23	#8 Int. Tooth Lock washer	9	0620-0010-1000
24	#8-32 Hex Nut	10	0410-0039-1000
25	#8-32 x 3/8" Lg. Rd. Hd. Scr.	5	0135-0040-1000
26	Wire Clamp	1	0620-0023-0000
27	Pivot Washer	1	0410-0009-1000
28	#8-32 x 1/2" Lg. Rd. Hd. Scr.	3	0150-0015-1000

Contact factory for other materials and/or parts not listed.

LIMITED WARRANTY

March pumps are guaranteed only against defects in workmanship or materials for a period of one year from date of manufacture pumping water. See March limited warranty statement on card #0410-0104-1000 packed with this pump.



1819 PICKWICK AVE., GLENVIEW, IL 60026-1306, U.S.A
 PHONE: (847) 729-5300 · FAX: (847) 729-7062 · www.marchpump.com

0618-0081-1000 R10