

Little GIANT[®]

Pump Company

TE-3-MD-HC



Features

- Thermally Protected, Totally Enclosed, Fan-Cooled Motor
- Ball Bearings
- 6' Power Cord with 3-Prong Plug (No plug on 230V)
- Specific Gravity to 1.1
- Fluid Temperature to 200 Degrees F.
- Ambient Air Temperature to 77 Degrees F.
- NOTE: Consult your local distributor or the factory for applications with higher ambient temperatures, specific gravities and viscosities.

Construction

- Volute — Glass-filled Ryton[®]
- Housing — Glass-filled Ryton[®]
- Impeller — Glass-filled Ryton[®] w/Carbon Bushing (581605 has Mica-filled Teflon Bushing)
- Shaft — Ceramic
- Thrust Washers — Ceramic
- O-Ring — Viton[®]

The Little Giant MD-HC series features leakproof, seal-less magnetic drives and are designed for in-line, non submersible use. Volute, magnet housing and impeller are glass-filled Ryton[®] for excellent chemical resistance. Ceramic shaft and thrust washers are 99.5% pure alumina for excellent wear and trouble-free service. Pumping heads are easily rotated, cleaned or serviced with no special tools required. Spindle shaft is supported at both ends to prevent impeller damage during start-up and stop of pump.

Little Giant Pump Co.

TE-3-MD-HC

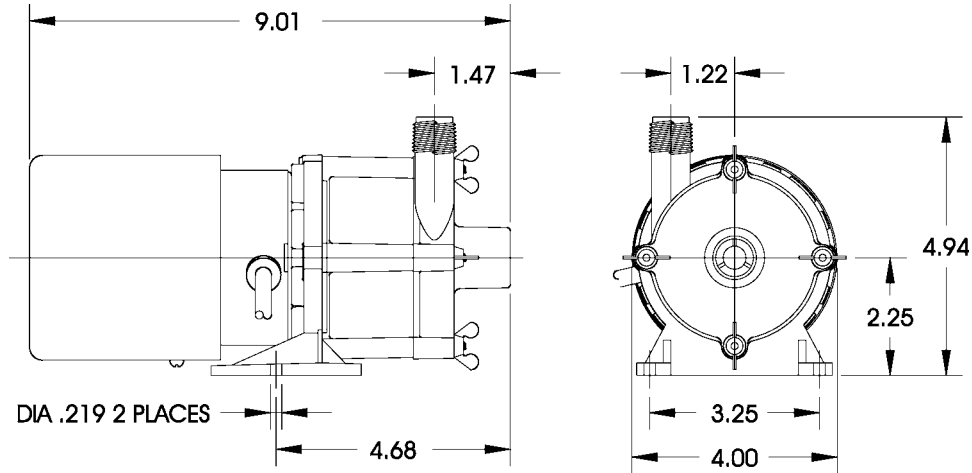

NOTE: Designs and dimensions may vary for various reasons (i.e. type of motor). This information should be used as general guide rather than an unqualified guarantee. Specifications are subject to change without prior notice.

Specifications

Model No.	Item No.	Intake	Discharge	Listing(s)	HP	Volts	Hertz	Amps	Watts	Performance (GPH @ Head)					Shut Off		Pwr. Cord (ft)	Weight (Lbs.)
										1'	3'	6'	9'	15'	Feet	PSI		
TE-3-MD-HC	581604	1/2" FNPT	1/2" MNPT	UR/C-CSA	1/25	115	60	1.3	94	590	545	490	390	150	16.3	7.1	6	8.80
TE-3-MD-HC	581605	1/2" FNPT	1/2" MNPT	UR/C-CSA	1/25	115	60	1.3	94	590	545	490	390	150	16.3	7.1	6	8.80
TE-3-MD-HC	581614	1/2" FNPT	1/2" MNPT	UR/C-CSA	1/20	230	50/60	1.1/8	135/115	590	545	490	390	150	16.3	7.1	6	8.80
TE-3-MD-HC	581698	1/2" FNPT	1/2" MNPT		PUMP HEAD LESS MOTOR													2.33

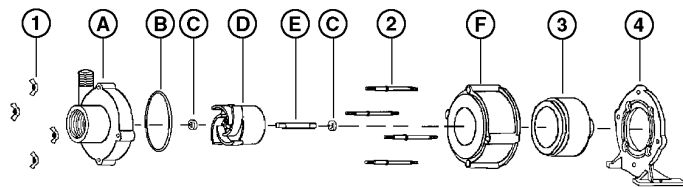

Replacement Parts

ITEM	PART NO.	DESCRIPTION
A	180080	Volute
B	924008	O-Ring
C	921077	Thrust Washer
D	181148	Impeller
D	181151	Impeller (for 581605)
E	180057	Shaft
F	182006	Housing
1	920003	Wing nut
2	911403	Stud, Collared
3	182602	Drive Magnet
4	180042	Mtg. Bracket

Note: Parts A-F Contact Fluid.

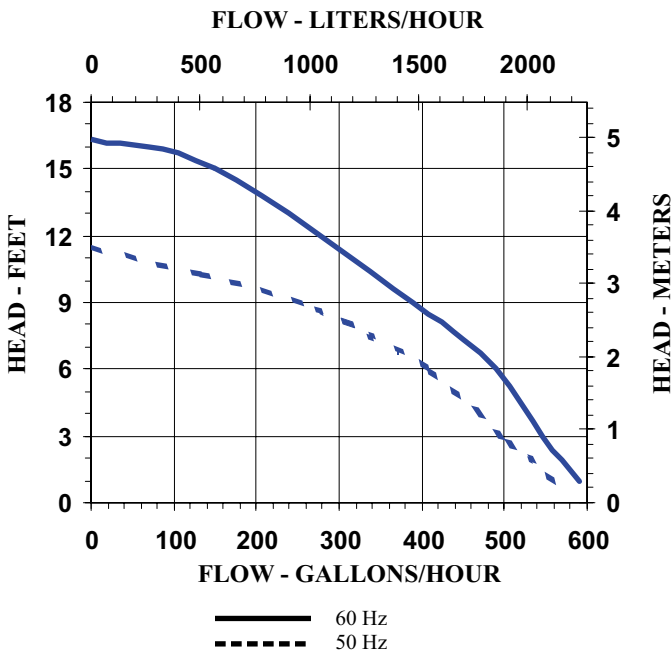

Little Giant Pump Co.
 PO Box 12010
 Okla. City, OK 73157
 Phone: 405.947.2511
 Fax: 405.228.1550
www.LittleGiantPump.com