

Little GIANT[®] Pump Company

OPWG-42/71/97



Features

- Thermally protected, enclosed, fan cooled, permanent split capacitor motor
- 115 or 230 Volt Operation (Pre-wired for 115V)
- Conduit Box (Must be field wired)
- 1-1/2" FNPT Intake and discharge ports
- Motors are enclosed for excellent protection and weather resistance
- Low power consumption
- For larger systems, plumb two or more units in parallel to economically multiply the flow

Construction

- Volute — Glass-Filled Polypropylene
- Volute Cover — Glass-Filled Polypropylene
- Impeller — Glass-Filled Noryl[®]
- Shaft Seal — Carbon/Ceramic

Cost Saving Efficiency

The Little Giant Professional Series of Pumps produce a maximum flow rate with minimal electrical consumption. The dollars saved from reduced operating costs can pay for the pump in a matter of months.

Safety

The Professional Series are end suction centrifugal pumps, designed to be located on the perimeter of the pond. This eliminates the need for wading into the pond to service the pump or pump intake filter. By locating the pump outside of the pond, you also greatly reduce the chance of electrical shock.

Reliability

The Professional Series was designed with the Professional in mind. Built tough, the pump housings are injection-molded of corrosion resistant thermoplastics, and are mounted to custom-built motors. Each Professional Series Pump is thoroughly tested prior to shipment. After proper installation, your pump will provide years of dependable, trouble free service.

Quiet Operation

Install these pumps wherever you desire. The Professional Series was designed for water gardening, not industrial applications, generating noise levels equivalent to a small electrical fan at 52 dB.

NOTE: For above the water level applications, a leaf basket (566106), is required to act as a priming chamber.

Little Giant Pump Co.

OPWG-42/71/97

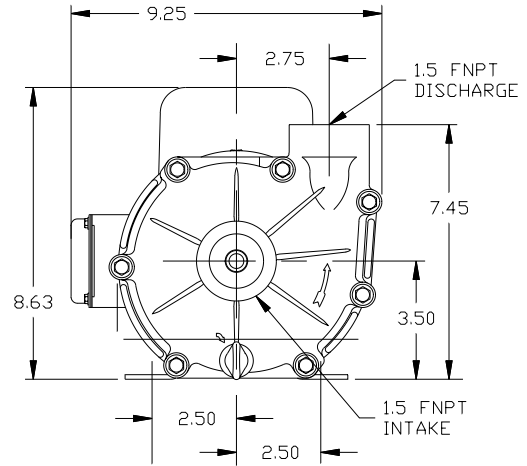
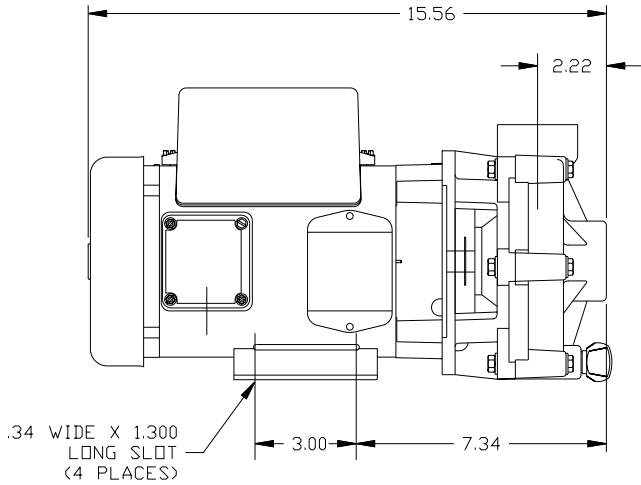

Specifications

Model No.	Item No.	Discharge Size	Intake Size	Listing(s)	HP	Volts	Hertz	Amps	Watts	Performance (GPM @ Head)				Shut Off		Pwr. Cord (ft)	Weight (Lbs.)	Height	Length	Width
										5'	10'	15'	20'	Feet	PSI					
OPWG-42	566022	1-1/2" FNPT	1-1/2" FNPT	UL/CSA	1/8	115/230	60	1.6/0.8	139	42	33	23	20	8.5	N/A	24.08	8.75	15.50	9.00	
OPWG-71	566023	1-1/2" FNPT	1-1/2" FNPT	UL/CSA	1/6	115/230	60	2.5/1.3	257	71	59	45	21	8.9	N/A	24.86	8.75	15.50	9.00	
OPWG-97	566024	1-1/2" FNPT	1-1/2" FNPT	UL/CSA	1/4	115/230	60	3.0/1.6	335	97	84	68	22	9.6	N/A	24.90	8.75	15.50	9.00	

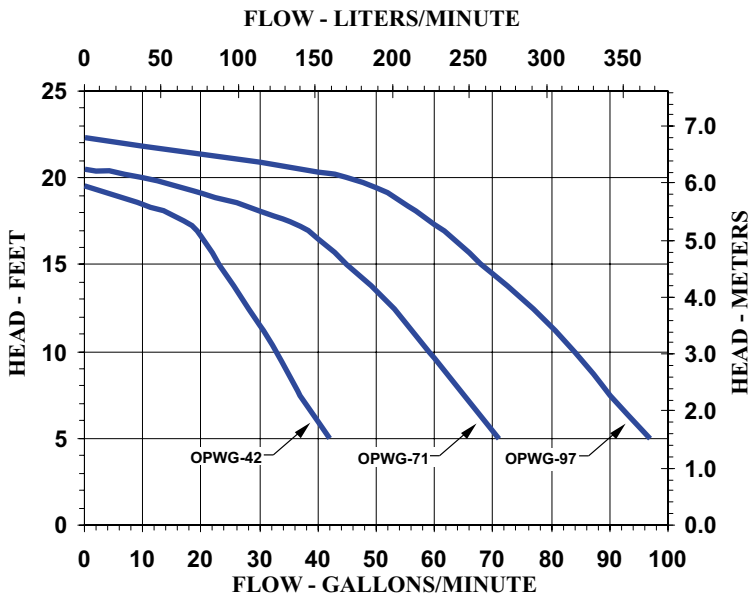

Replacement Parts

Part No.	Description
166202	Impeller OPWG-42
166203	Impeller OPWG-71
166204	Impeller OPWG-97
166206	Bracket
166208	Volute
166209	Drain Plug w/O-Ring
924042	O-Ring, Volute
926046	Seal Assy, Ceramic/Carbon

Little Giant Pump Co.
 PO Box 12010
 Okla. City, OK 73157
 Phone: 405.947.2511
 Fax: 405.228.1550
www.LittleGiantPump.com