

9S SERIES

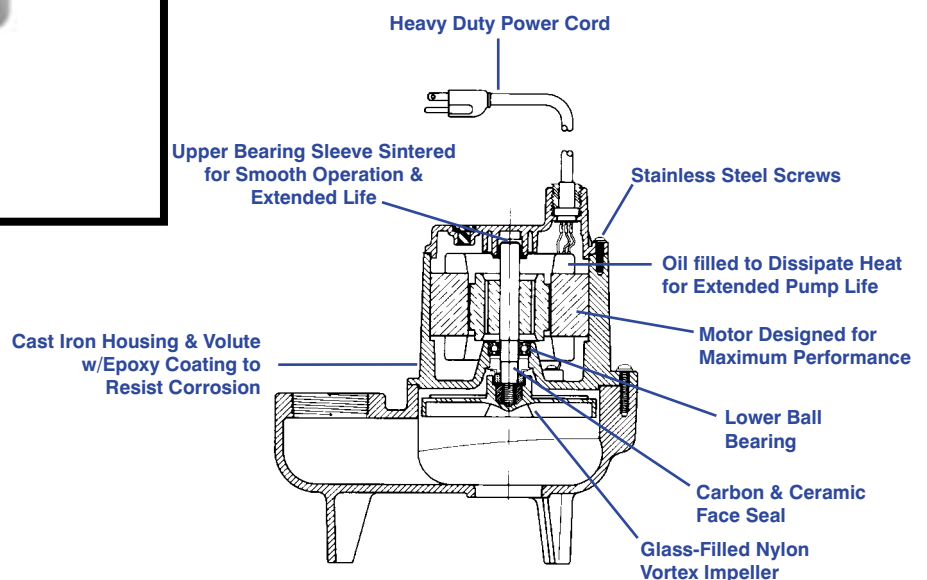

Features

- Handles liquids and solid waste materials up to 2" diameter.
- Cast iron pump housing with protective epoxy coating for corrosion resistance
- Oil-filled motor housing for lifetime lubrication and rapid heat dissipation
- Stainless steel fasteners
- Mechanical seals (stainless steel spring, nitrile parts, carbon and ceramic faces)
- Thermal overload protection
- Manual and Automatic models in each size.
- Automatic operation has 9" to 14" "On" level and 2" to 6" "Off" level range with piggyback mechanical float switch.
- All 115 volt models are UL/CSA listed.



For residential, medium commercial and agricultural, and light industrial applications, the Model 9S Series Wastewater and Sewage Ejector pumps feature a 2" discharge, with a maximum lift of 18'. Cast iron housing and volute have a protective epoxy coating.

Little Giant Pump Co.

9S SERIES SEWAGE PUMP

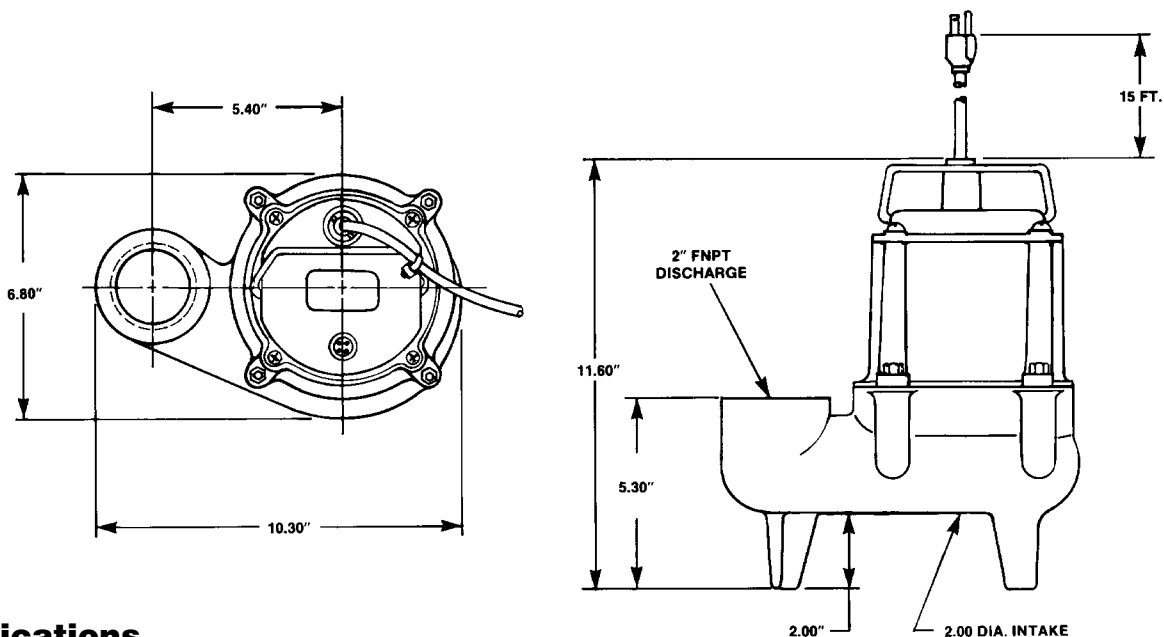

Specifications

MODEL NO.	ITEM NO.	LISTING	HP	VOLTS	SOLIDS SIZE (Dia. In.)	RUNNING AMPS/WATTS	PERFORMANCE (GPM @ HEAD)				SHUTOFF (Ft.)	PWR. CRD. (Ft.)	WEIGHT (Lbs.)	DIMENSIONS (H x L x W in.)	
							5'	10'	15'	20'					
9S-CIM	509400	UL/CSA	4/10	115	2"	13/1020	80	50	16	—	18	7.8	15	36	11.6 x 10.3 x 6.8
9S-CIA-RFS	509500	UL/CSA	4/10	115	2"	13/1020	80	50	16	—	18	7.8	15	36	11.6 x 10.3 x 6.8
9S-CIM	509450	—	4/10	230	2"	6.5/1020	80	50	16	—	18	7.8	15*	36	11.6 x 10.3 x 6.8
9S-CIA-RFS	509520	UL/CSA	4/10	115	2"	13/1020	80	50	16	—	18	7.8	20	37	11.6 x 10.3 x 6.8
9S-CIA-RFS*	509510	UL/CSA	4/10	115	2"	13/1020	80	50	16	—	18	7.8	15	37	11.6 x 10.3 x 6.8

*3" discharge RFS - Piggyback Mechanical Float Switch

* w/out plug



PUMP PERFORMANCE CURVE

115V 60Hz

Construction

Cover	Nylon
Motor Housing	Epoxy Coated Cast Iron
Impeller Material	Nylon
Impeller Type	Vortex
Volute	Epoxy Coated Cast Iron
Power Cord	SJTW
Mechanical Shaft Seal	Nitrile with carbon and ceramic faces
Fasteners	Stainless Steel
Shaft	Steel
Bearings	Upper sintered sleeve and lower ball bearing



ISO 9001 CERTIFIED

Little Giant Pump Co.

PO Box 12010
Okla. City, OK 73157

Phone: 405.947.2511
Fax: 405.228.1550

www.LittleGiantPump.com

Form No. 994342 - 11/99