

9E SERIES

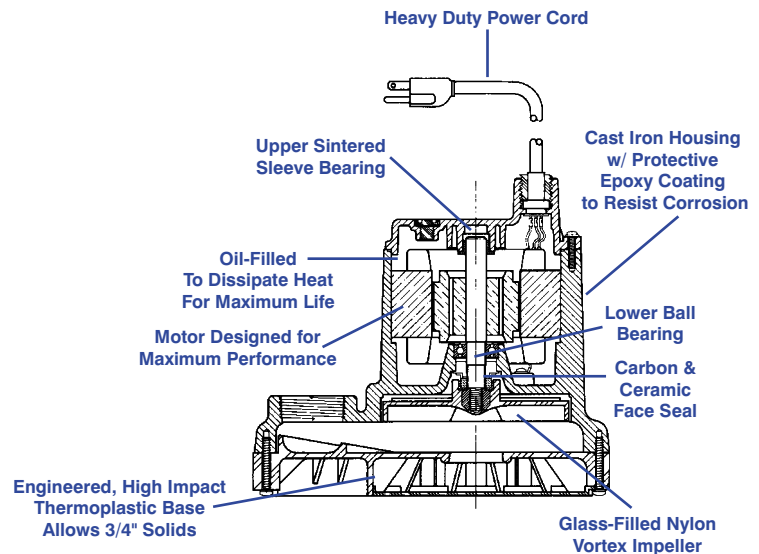

Features

- Handles liquids and solid waste materials up to 3/4" diameter.
- Cast iron pump housing with protective epoxy coating for corrosion resistance
- Oil-filled motor housing for lifetime lubrication and rapid heat dissipation
- Stainless steel screws, bolts and handle
- Mechanical seals (stainless steel spring, nitrile parts, carbon and ceramic faces)
- Bearings: Lower-Ball Bearing
- Thermal overload protection
- Manual and Automatic models
- Automatic operation has 9 to 14 "On" level and 2 to 6 "Off" level range with integral remote float switch.
- All 115 volt models are UL/CSA listed.



The Model 9E Series De-watering and Effluent pumps are for residential and light to medium commercial use. Pumps feature a 1-1/2" discharge with a lift of 23', glass-filled nylon cover and ABS base.

Little Giant Pump Co.

9E SERIES SUMP/EFFLUENT PUMP

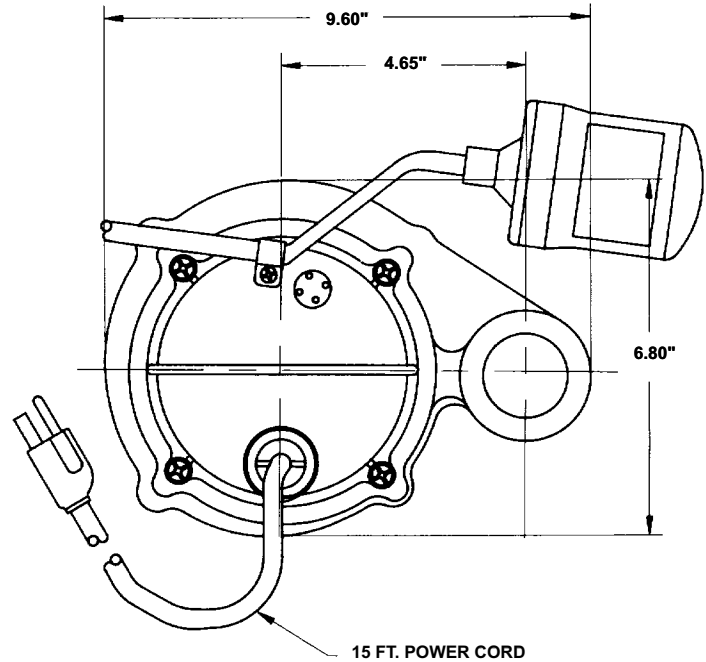
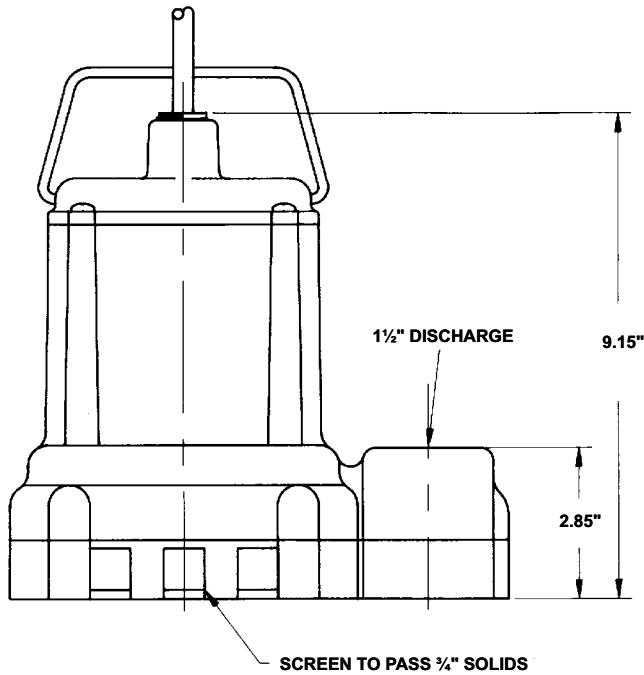

Specifications

MODEL NO.	ITEM NO.	LISTING	HP	VOLTS	SOLIDS SIZE (Dia. In.)	RUNNING AMPS/WATTS	PERFORMANCE (GPM @ HEAD)				SHUTOFF (Ft.)	PWR. CRD. (Ft.)	P.S.I.	WEIGHT (Lbs.)	DIMENSIONS (H x L x W in.)
							5'	10'	15'	20'					
9E-CIM	509200	UL/CSA	4/10	115	3/4	12.3/1000	57	53	40	15	23	10	15	26	9.15 x 9.6 x 6.8
9E-CIA-RFS	509300	UL/CSA	4/10	115	3/4	12.3/1000	57	53	40	15	23	10	15	27	9.15 x 9.6 x 6.8
9E-CIM	509250	—	4/10	230	3/4	6.2/1000	57	53	40	15	23	10	15*	26	9.15 x 9.6 x 6.8
9E-CIA-RFS	509320	UL/CSA	4/10	115	3/4	12.3/1000	57	53	40	15	23	10	20	28	9.15 x 9.6 x 6.8
9E-CIM	509225	UL/CSA	4/10	115	3/4	12.3/1000	57	53	40	15	27	10	25	26	9.15 x 9.6 x 6.8

* w/out plug

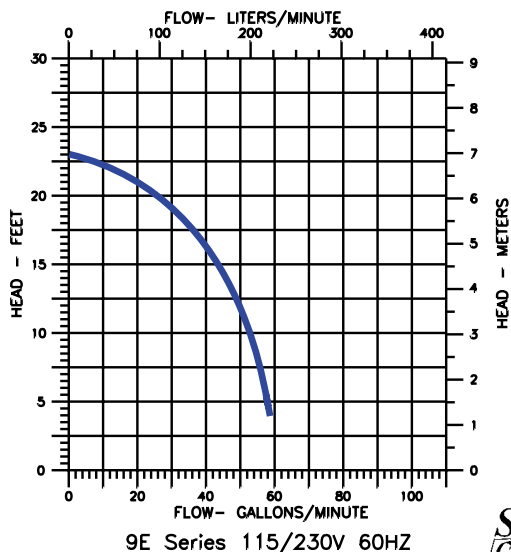

Construction

Cover	Nylon
Motor Housing	Epoxy Coated Cast Iron
Impeller Material	Nylon
Impeller Type	Vortex
Volute	Epoxy Coated Cast Iron
Power Cord	SJTW-A
Mechanical Shaft Seal	Nitrile with carbon and ceramic faces
Fasteners	Stainless Steel
Shaft	Steel
Bearings	Upper Sleeve and Lower Ball Bearings



ISO 9001 CERTIFIED

Little Giant Pump Co.

PO Box 12010
Oklahoma City, OK 73157

Phone: 405.947.2511
Fax: 405.228.1550

www.LittleGiantPump.com

Form No. 994341 - 11/99