

## 6E-CIA-SFS

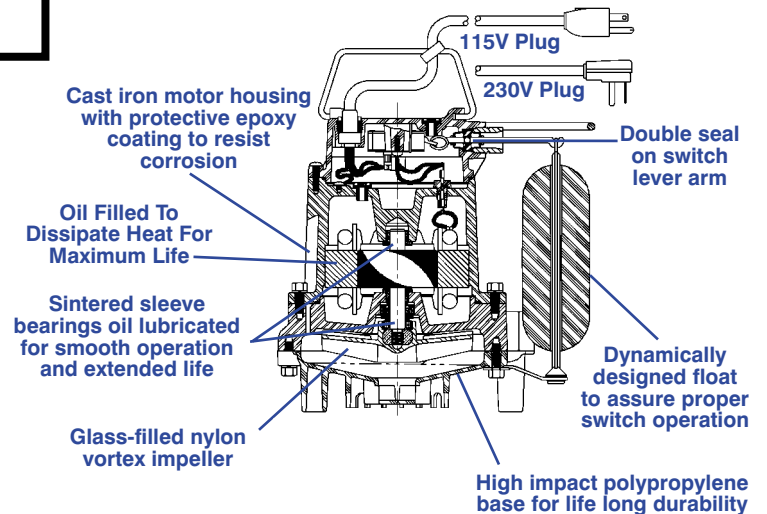

### Features

- Handles liquid and solid waste materials up to 1/2" diameter
- Cast iron pump housing with protective epoxy coating for corrosion and rust resistance
- Oil-filled motor housing for lifetime lubrication and rapid heat dissipation
- 1/3 hp Shaded Pole Motor
- Stainless steel screws, bolts and handle
- Mechanical seals (stainless steel spring, nitrile parts, carbon and ceramic faces)
- Bearings: upper and lower sintered sleeve bearings
- Thermal overload protection
- Automatic operation has 7"-10" "On" level range and 2"-5" "Off" level range
- Integral Snap Action Float Switch
- All models are UL and CSA listed



The model 6E Series Sump and Effluent Pumps are for residential and light commercial use. Pumps feature a 1-1/2" FNPT discharge with a lift of 20', polypropylene base and polycarbonate cover.

# Little Giant Pump Co.

## 6E-CIA-SFS SUMP/EFFLUENT PUMP

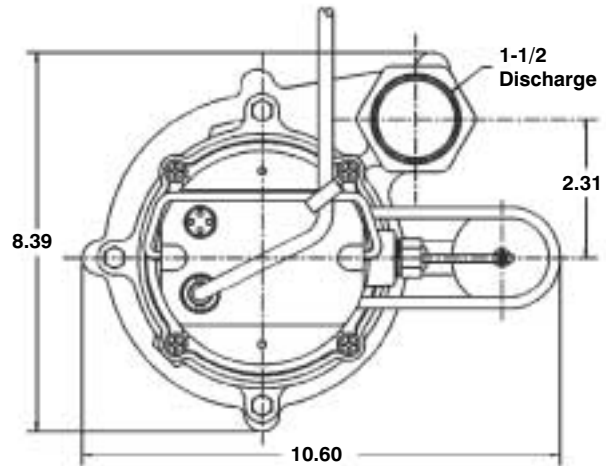
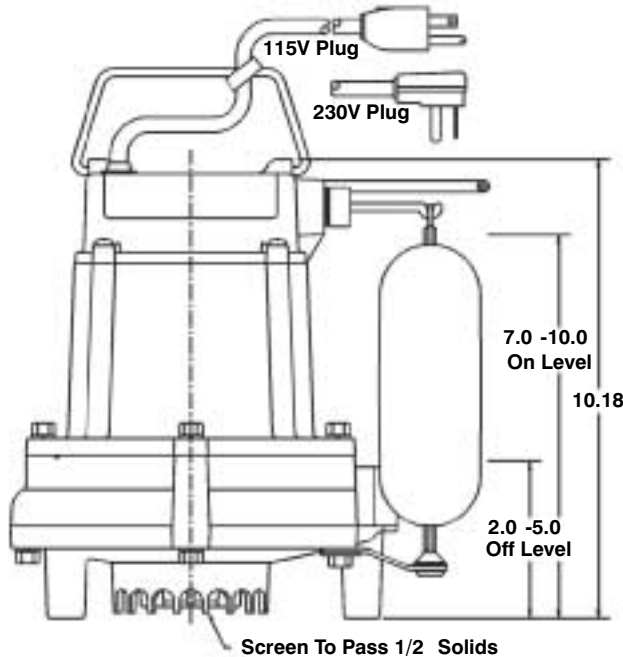

### Specifications

MODEL NO.	ITEM NO.	LISTING	HP	VOLTS	SOLIDS (DIA.)	RUNNING AMPS/WATTS	PERFORMANCE (GPM @ HEAD)			SHUTOFF		PWR CORD (FT.)	WEIGHT (LBS)	DIMENSIONS (H x L x W in.)
							5'	10'	15'	(FT.)	PS.I.			
6E-CIA-SFS	506700	UL/CSA	1/3	115	1/2"	10/750	50	42	27	20'	8.7	10	27	10.18 x 10.60 x 8.39
6E-CIA-SFS	506701	UL/CSA	1/3	115	1/2"	10/750	50	42	27	20'	8.7	25	28	10.18 x 10.60 x 8.39
6E-CIA-SFS	506720	UL/CSA	1/3	230*	1/2"	4.8/890	50	42	27	20'	8.7	15	28	10.18 x 10.60 x 8.39

\*50/60 HZ. Performance Data Based on 60 Hz.

SFS - Snap Action Float Switch

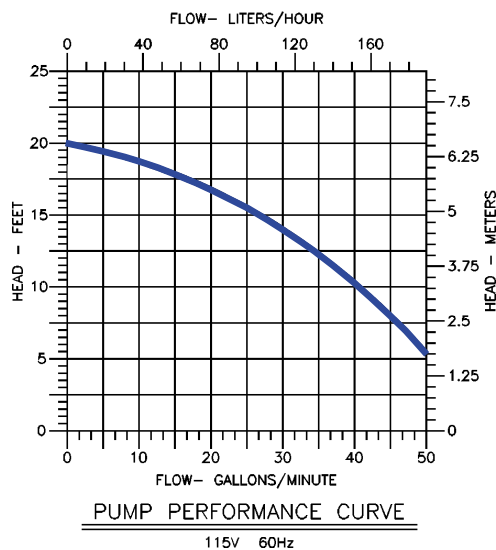

### Construction

Cover	Polycarbonate
Motor Housing	Epoxy Coated Cast Iron
Impeller Material	Nylon
Impeller Type	Vortex
Volute	Epoxy Coated Cast Iron/Polypropylene
Power Cord	SJTW-A
Mechanical Shaft Seal	Nitrile with carbon and ceramic faces
Fasteners	Stainless Steel
Shaft	Cold Rolled Steel
Bearings	Upper and lower sintered sleeve bearings



ISO 9001 CERTIFIED

**Little Giant Pump Co.**

PO Box 12010  
Okl. City, OK 73157

Phone: 405.947.2511  
Fax: 405.228.1550

[www.LittleGiantPump.com](http://www.LittleGiantPump.com)

Form No. 995226 - 05/01