

Little GIANT[®]

Pump Company

3E-12NR SERIES



Features

- For submersed or in-line use
- Epoxy coated die-cast aluminum housing
- Oil-filled motor
- 22.6' maximum lift
- 200 watts
- 1/2" MNPT discharge
- Thermal overload protection

Construction

- Motor — 1/15 HP Oil-filled
- Intermittent Liquid Temp. up to — 120° F
- Intake — 1/2" FNPT
- Discharge — 1/2" MNPT
- Housing — Epoxy coated cast aluminum
- Cover — Epoxy coated cast aluminum
- Volute — Nylon
- Impeller — Nylon
- Shaft Seal — Viton[®]
- Screen — Polypropylene

Dual purpose oil-filled pump that may be used totally submersed or in-line (fed with pipe or hose). For commercial, industrial and home applications including statuary fountains, water displays, air conditioners, machine tool coolants, and many other applications where liquid must be transferred or recirculated. This compact 670 GPH pump features a 1/2" MNPT discharge and 22.6' shut-off head capability.

Little Giant Pump Co.

3E-12NR SERIES

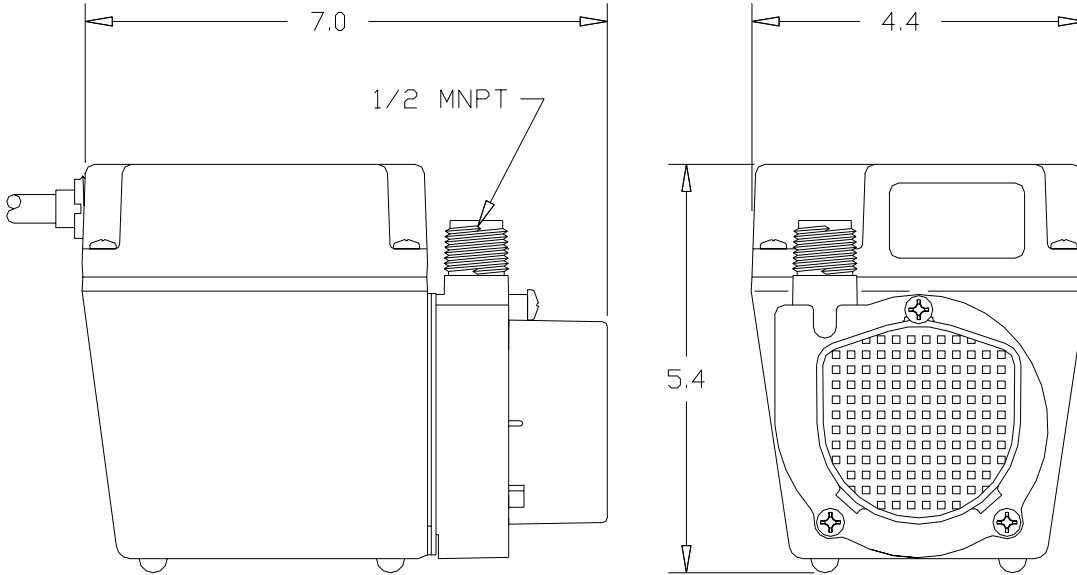

Specifications

Model No.	Item No.	Discharge	Intake	Listing(s)	HP	Volts	Hertz	Amps	Watts	Performance (GPH @ Head)					Shut Off		Pwr. Cord (ft)	Weight (Lbs.)
										1'	3'	5'	10'	20'	Feet	PSI		
3E-12NR	503203	1/2" MNPT	1/2" FNPT	UL	1/15	115	60	3.2	200	670	650	575	460	100	22.6	9.8	6	8.00

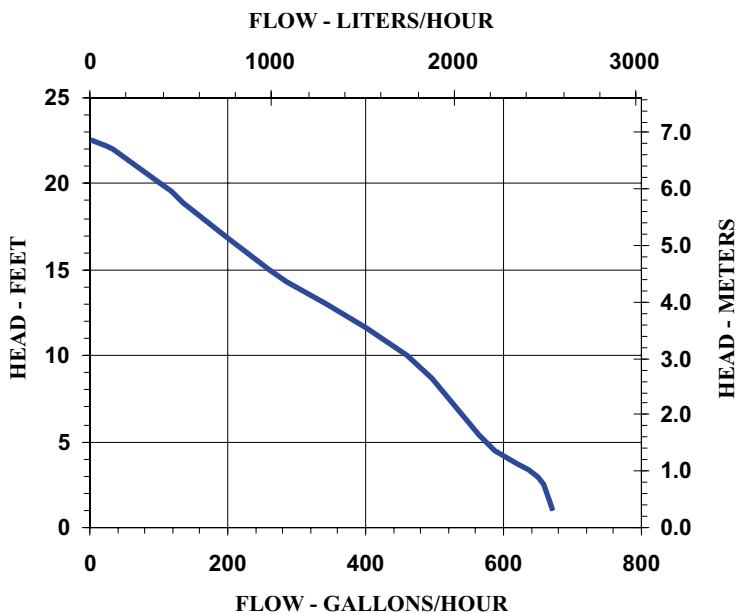

Replacement Parts

Volute	103330
Impeller	103437
Screen	102909
Gasket	103601

Little Giant Pump Co.
 PO Box 12010
 Okla. City, OK 73157
 Phone: 405.947.2511
 Fax: 405.228.1550
www.LittleGiantPump.com