

# Little GIANT<sup>®</sup> Pump Company

## 34C-SPT



### Features

- Permanently lubricated
- Epoxy coated cast aluminum housing
- Automatic, in-pan design
- Leak proof, rust proof, ABS plastic tank
- 1/2" MNPT discharge with check valve for 1/2" OD rigid-plastic or copper tubing
- 26' max lift

### Construction

- Motor — 1/12 HP
- Intermittent Liquid Temp. up to — 120° F
- Intake — N/A
- Discharge — 1/2" MNPT
- Housing — Epoxy coated cast aluminum
- Cover — Epoxy coated cast aluminum
- Volute — Nylon
- Impeller — Nylon
- Shaft Seal — Nitrile
- Screen — Polyethylene

Automatic condensate removal pump that features an "on" level in 4-1/2" of water and "off" level in 3-1/2" of water. The pump is permanently lubricated and designed to maximize heat dissipation. This model includes a 1/2" MNPT discharge with check valve for 1/2"OD rigid-plastic or copper tubing and 1 gallon ABS tank.

# Little Giant Pump Co.

## 34C-SPT

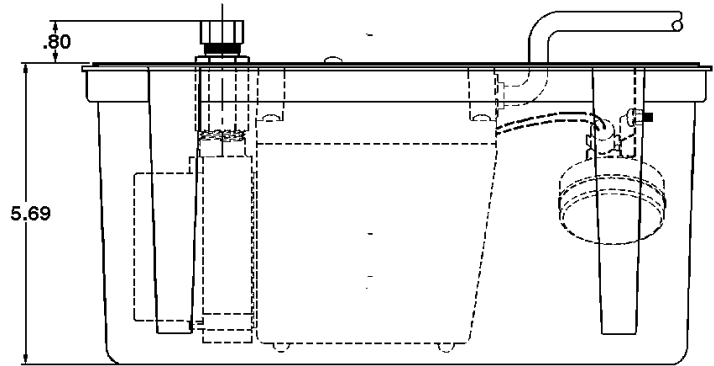
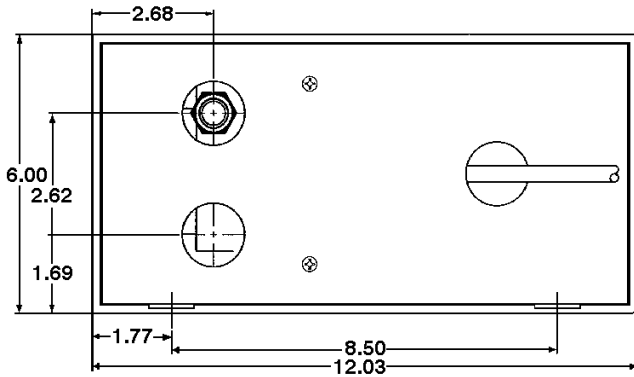

### Specifications

Model No.	Item No.	Discharge Size	Listing(s)	HP	Volts	Hertz	Amps	Watts	Performance (GPH @ Head)					Shut Off Feet	PSI	Pwr. Cord (ft)	Weight (Lbs.)	Height	Length	Width
									1'	3'	5'	10'	20'							
34C-SPT	551301	1/2" MNPT		1/12	115	60	3.5	210	310	290	280	250	110	26	11.2	6	6.25	11.00	12.00	6.00
34C-SPT	551311	1/2" MNPT		1/12	230	50/60	1.8	210	310	290	280	250	110	26	11.2	12	6.25	11.00	12.00	6.00

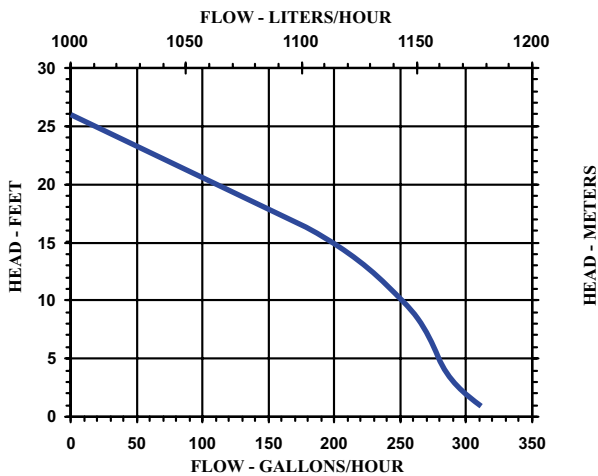

### Replacement Parts

Tank	153502
Cover	151420
Float Lever Assy	151312
Check Valve	940003
Volute	103330
Screen	102909
Impeller	104435
Gasket	103601

### Little Giant Pump Co.

PO Box 12010  
Oklahoma City, OK 73157

Phone: 405.947.2511  
Fax: 405.228.1550

[www.LittleGiantPump.com](http://www.LittleGiantPump.com)

Form No. 995122 - 12/00