

14S SERIES

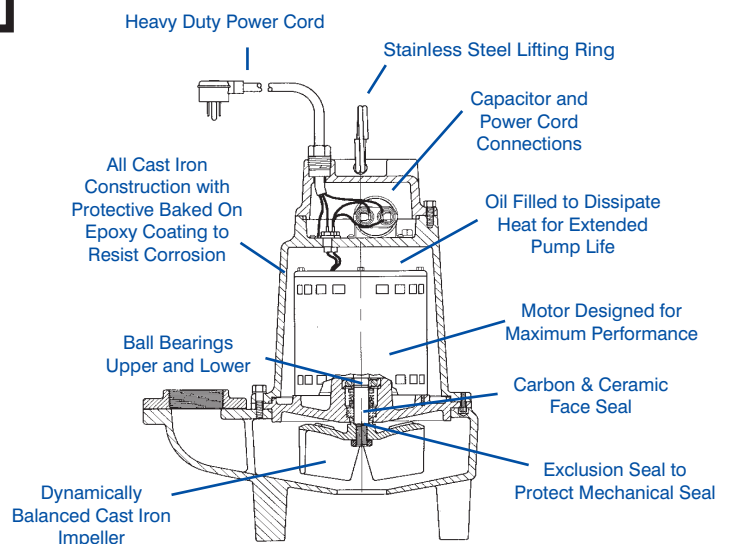

Features

- Handles liquids and solid waste materials up to 2" diameter.
- Cast iron pump housing with protective epoxy coating for corrosion resistance
- Oil-filled motor housing for lifetime lubrication and rapid heat dissipation
- Stainless steel screws, bolts and lifting ring
- Mechanical seal (stainless steel spring, nitrile parts, carbon and ceramic faces) for long life & reliability
- Secondary Exclusion Seal to help protect mechanical seal
- 1/2 HP, 1625 RPM, ball bearing motor and thermal overload protection
- Capacitor & power cord connections isolated from oil filled motor housing for ease of field maintenance
- Dynamically balanced two-vane non-clogging impeller with pump-out vanes to enhance pumping performance & efficiency



For Residential, Commercial, Industrial and Agricultural use. The model 14S Series Wastewater and Sewage Ejector pumps handle liquids and solid waste materials up to 2" in diameter. Pumps feature either a 2" or 3" FNPT discharge with a maximum head of 25', heavy duty cast iron construction and stainless steel hardware.

Little Giant Pump Co.

14S SERIES SEWAGE EJECTOR PUMP

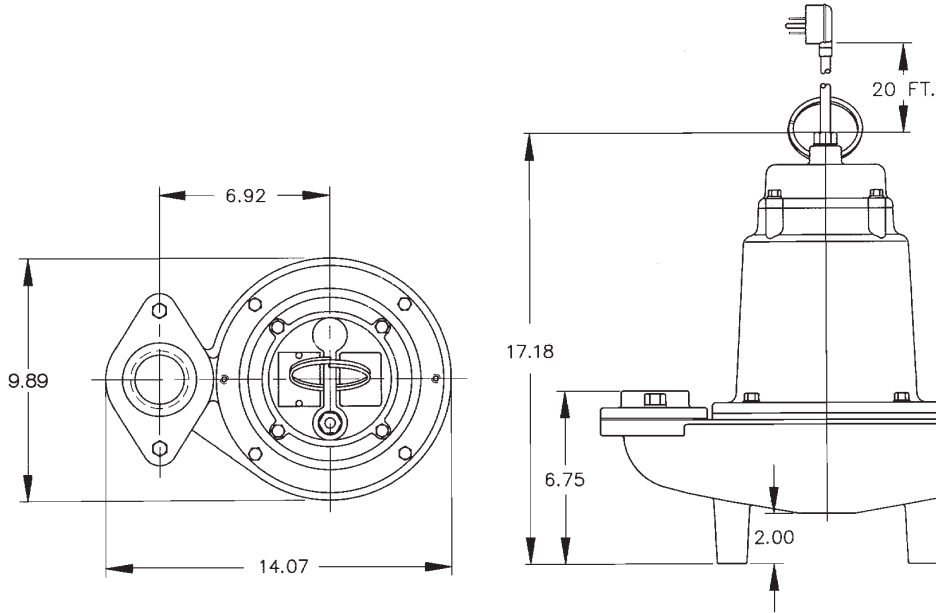

Specifications

MODEL NO.	ITEM NO.	DISCHARGE	SOLIDS SIZE (Dia. In.)	LISTING	HP	VOLTS	PHASE	Hz.	RPM	RUNNING AMPS/WATTS	SHUT OFF (Ft.)	P.S.I.	PWR CRD (Ft.)	WEIGHT (Lbs.)
14S-CIM	514320	2" FNPT	2"	UL/CSA	1/2	115	1	60	1625	11.6/1100	25'	10.8	20'	80
14S-CIM	514420	3" FNPT	2"	UL/CSA	1/2	115	1	60	1625	11.6/1100	25'	10.8	20'	80
14S-CIM	514321	2" FNPT	2"	UL	1/2	208/240	1	60	1625	4.6/1100	25'	10.8	20'	80

Continuous Duty Rated — "Little Giant Wastewater pumps are rated continuous duty as long as they are run within the published ratings for these pumps."

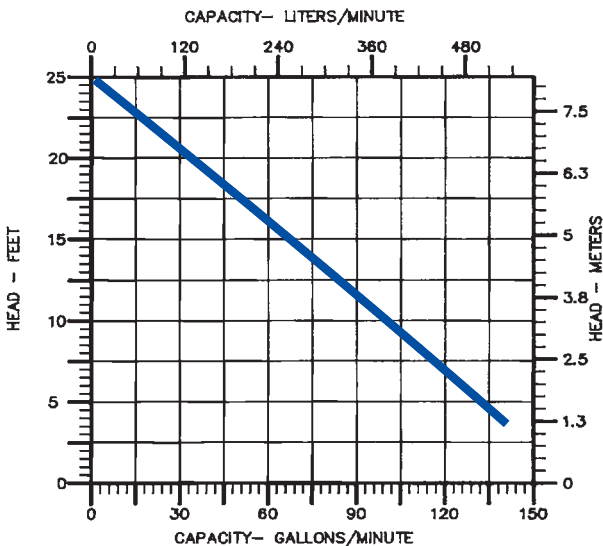

PUMP PERFORMANCE CURVE

Construction

Motor Housing	Epoxy Coated Cast Iron
Impeller Material	Epoxy Coated Cast Iron
Impeller Type	Two Vane, non-clog
Volute	Epoxy Coated Cast Iron
Power Cord	16/3, STW
Mechanical Shaft Seal	Nitrile Parts with Carbon/Ceramic Faces
Fasteners	Stainless Steel
Shaft	Stainless Steel
Bearings	Upper and lower ball bearings