

Little GIANT[®]

Pump Company

1-EUAA-MD

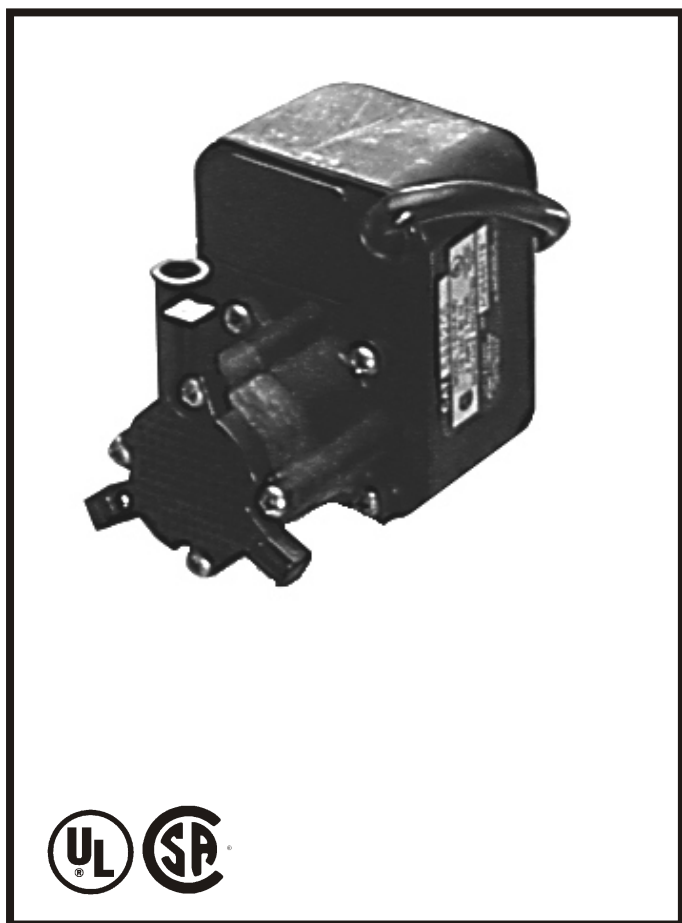

Features

Thermally Protected, Epoxy Encapsulated Motor
 For Submersible or In-line Use
 6' Power Cord with 3-Prong Plug
 Specific Gravity to 1.1
 Fluid Temperature to 120 Degrees F.
 NOTE: Consult your local distributor or the
 factory for applications with higher ambient
 temperatures, specific gravities and viscosities.

Construction

Volute — Glass-filled Polypropylene
 Magnet Housing — Glass-filled Polypropylene
 Impeller — Glass-filled Polypropylene &
 Ceramagnet "A" (Barium Ferrite)
 Shaft — Ceramic
 Thrust Washers — Rulon "J" (Teflon)
 O-Ring — Nitrile
 Motor Housing — Polyester/Polyethylene/
 Epoxy/PVC

The Little Giant 1-EUAA-MD series features leakproof, seal-less magnetic drives and are designed for in-line or submersible use. Volute and magnet housing are glass-filled polypropylene for excellent chemical resistance. Impeller is glass-filled polypropylene and Ceramagnet "A" (Barium Ferrite). Shaft is ceramic and thrust washers are Rulon "J" (Teflon) for excellent wear and trouble-free service. Pumping heads are easily rotated, cleaned or serviced with no special tools required. Spindle shaft is supported at both ends to prevent impeller damage during start-up and stop of pump.

Little Giant Pump Co.

1-EUAA-MD

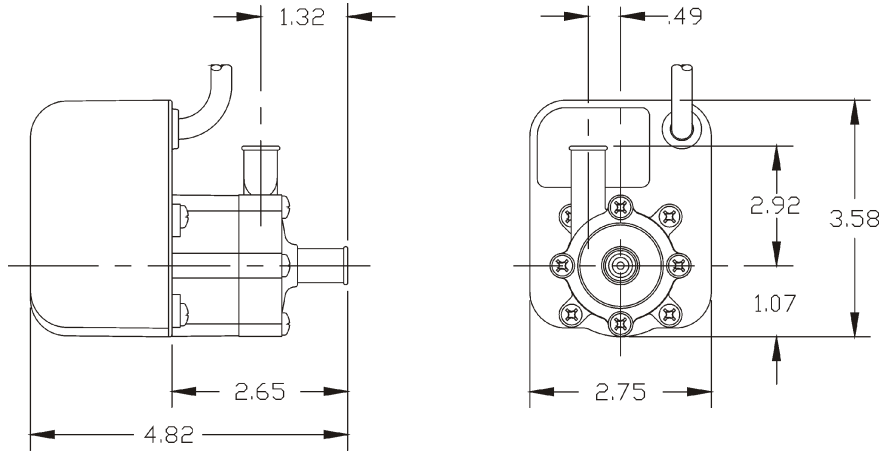

NOTE: Designs and dimensions may vary for various reasons (i.e. type of motor). This information should be used as general guide rather than an unqualified guarantee. Specifications are subject to change without prior notice.

Specifications

Model No.	Item No.	Intake	Discharge	Listing(s)	HP	Volts	Hertz	Amps	Watts	Performance (GPH @ Head)		Shut Off		Pwr. Cord (ft)	Weight (Lbs.)
										1'	3'	Feet	PSI		
1-EUAA-MD	588205	1/2" Hose	1/2" Hose	UL/CSA	1/200	115	60	0.3	17	150	105	5.0	2.2	6	3.00

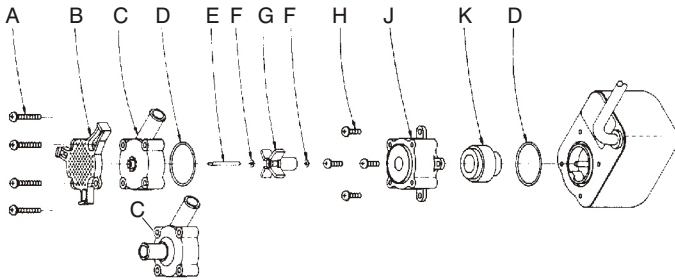

Replacement Parts

ITEM	PART NO.	DESCRIPTION
A	902420	Screw
B	188901	Screen
C	188015	Volute, Smooth
C	188016	Volute, In-Line
D	924028	O-Ring
E	188051	Shaft
F	921065	Thrust Washer
G	188105	Impeller
H	902442	Screw
J	188004	Housing
K	118124	Drive Magnet

Note: Parts A-K Contact Fluid.

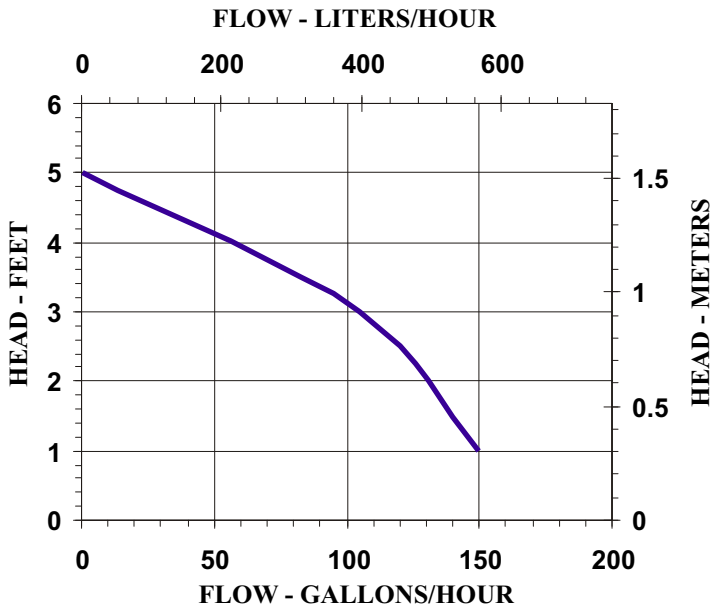

Little Giant Pump Co.
 PO Box 12010
 Okla. City, OK 73157
 Phone: 405.947.2511
 Fax: 405.228.1550
www.LittleGiantPump.com