

Little GIANT[®]

Pump Company

1-EA-42 SERIES



Features

- For submersible or in-line use
- Epoxy encapsulated motor
- 7' maximum lift
- 36 watts
- 1/4" MNPT discharge
- Thermal overload protection

Construction

- Motor — 1/125 HP Epoxy encapsulated
- Maximum Flow Rate — 170 GPH @ 1'
- Maximum Head — 7'
- Intermittent Liquid Temp up to — 120° F
- Intake — 1/2" MNPT & 1/4" FNPT
- Discharge — 1/4" MNPT
- Housing — Glass filled polyester
- Cover — Epoxy coated cast aluminum
- Volute — Nylon
- Impeller — Nylon
- Shaft Seal — Viton[®]
- Electrical — 115V, 60HZ

Dual purpose epoxy encapsulated pump that may be used totally submersed or in-line (fed with pipe or hose). For commercial, industrial and home applications including statuary fountains, water displays, air conditioners, machine tool coolants and many other applications where liquid must be transferred or recirculated. This compact 170 GPH pump features a 1/4" MNPT discharge and 7' shut-off head capability.

Little Giant Pump Co.

1-EA-42 SERIES

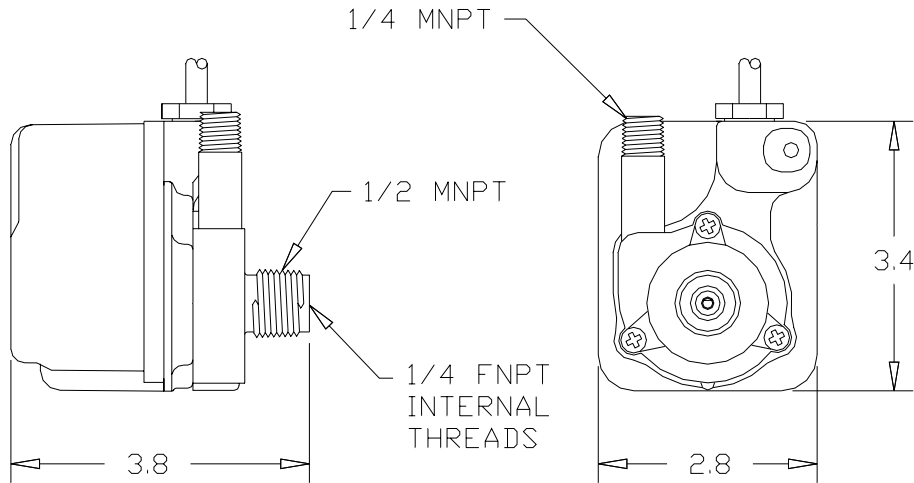

Specifications

Model No.	Item No.	Discharge	Intake	Listing(s)	HP	Volts	Hertz	Amps	Watts	Performance (GPH @ Head)			Shut Off		Pwr. Cord (ft)	Weight (Lbs.)
										1'	3'	5'	Feet	PSI		
1-EA-42	518087	1/4" MNPT	1/2" MNPT & 1/4" FNPT	UL/CSA	1/125	115	60	0.6	36	170	140	100	7	3.0	10	3.17

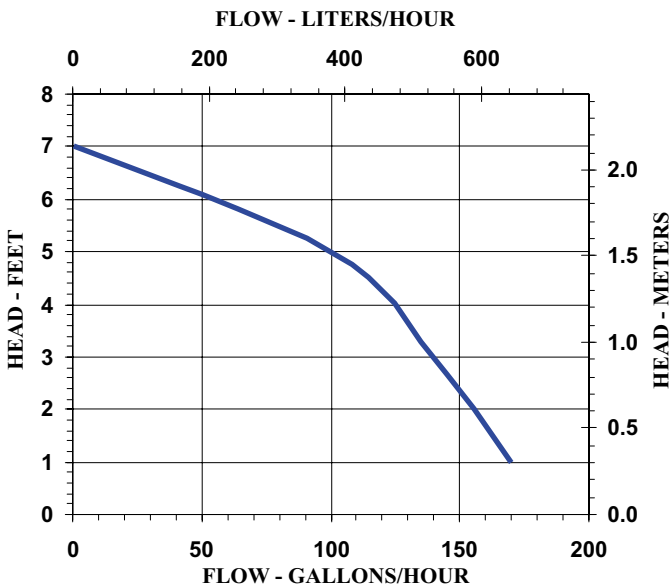

Replacement Parts

Volute	101377
Impeller	118442
Gasket	131009

Little Giant Pump Co.
 PO Box 12010
 Okla. City, OK 73157
 Phone: 405.947.2511
 Fax: 405.228.1550
www.LittleGiantPump.com