



Liberty Pump, Inc.

Liberty Pump Series - Owners Manual L - Operation & Assembly

OPERATING PRINCIPLE of the Progressing Cavity Pump is based on two pumping elements consisting of a helical Rotor turning within a double thread helical Stator. The meshing helical surfaces push the liquid ahead with uniform movement and low turbulence similar to a slow moving piston in a cylinder of infinite length. The screw-like Rotor rolls within the nut-like Stator with an eccentric rolling movement.

1. The Rotor provides an effective seal of liquid flow from port to port at all positions of rotation.
2. Displacement is positive and proportional to pump speed.
3. Pressure is independent of the pump speed.
4. There are no valves in the pump.

DRY FRICTION is harmful to this pump. Do not run the pump under power until it is filled with the liquid to be pumped. This liquid serves as a lubricant rather than a prime, since a flow of 10% of the pump displacement will satisfy cooling and lubricating requirements.

BASE & FOUNDATION

1. A concrete pier of liberal dimensions and having a level top surface makes an excellent foundation.
2. A fabricated structural steel base properly machined makes a very satisfactory base.
3. Lag screws or imbedded hold-down bolts for mounting base to foundation should be used.
4. Do not warp structural steel base by Pulling down to uneven foundation surface shim, instead.

ALIGNMENT OF DIRECT DRIVEN PUMP & DRIVE should be carefully checked after the base has been fastened down to the foundation. A 1/16" gap should be uniform. Drives should be re-aligned after reaching destination by loosening drive mounting bolts and aligning drive to best running tone.

BELT DRIVEN PUMPS should be checked after base has been fastened down to the foundation to make sure belts and pulleys are still in alignment and that the belts have the proper amount of tension.

ROTATION OF PUMP with the exception of a few larger models can be arranged to operate in either direction. A rotation plate is mounted on each pump, plainly designating the recommended direction for correct operating. This information is furnished by the pump manufacturer and is in accordance with the information received concerning the service and duty of each pump. Both inlet and outlet port designations are related to this rotation inasmuch as the Progressing Cavity Pump is fully reversible. Pump rotation is always determined when viewing the pump from the shaft extension of pulley end. If in doubt check with the factory.

PIPING TO PUMP should generally be equal in size to the pump port opening. Pipe systems handling viscous, volatile, or high temperature materials are often exceptions to this rule.

1. All screwed joints should be carefully "doped" before tightening.
2. Connected piping should make pump port fittings free of strain.
3. Make all lines as direct and free of fittings as possible and minimize suction line length by locating pump near source of liquid.



Liberty Pump, Inc.

Liberty Pump Series - Owners Manual

L - Operation & Assembly (Cont.)

VALVES of plug type are superior for most special purpose duties. Gate valves are satisfactory for thin, clear liquids, and globe valves are least satisfactory of all. Avoid use of globe valves in suction lines and when used otherwise make sure that they are in circuit correctly. Strainers and foot valves must be in good working order to be beneficial, otherwise it is often better to omit them.

PUMP BEARINGS are ball bearings on all sizes except the #12. This drive size has roller bearings. All bearings are grease lubricated.

1. Do not give these bearings routine lubrication because far more bearings are ruined due to over-attention and improper attention than otherwise.
2. Use a quality Anti-Friction Bearing Grease.
3. It is recommended, under normal use, that no lubrication be added for the first twelve months of operation.
4. At the end of this time the bearing-shaft assembly should be removed and washed with clean benzine.
5. All old grease should be removed from the bearing housing and only enough new grease applied to bearing races so as to fill them flush.
6. Add a few drops of oil to bearing seals before re-mounting assembly.

It takes several days of running for grease lubricated ball bearings in a new pump or relubricated pump to level off to final running temperature. Prior to reaching this condition the bearings might run hot to the extent that it is not comfortable to hold the hand on the housing.

PACKING MAINTENANCE PROCEDURES

1. Adjustment of packing gland should be kept sufficiently snug so as to prevent leakage but not so tight that the stuffing box feels hot to the touch. Gland bolts must be kept evenly adjusted.
2. Nearly all Progressing Cavity Pumps are supplied with a lantern ring in the mid-section of the packing and a grease fitting communicating with it. Careful lubrication of the packing with a grease insoluble in the liquid pumped will pay dividends. Greasing often but with limited quantities is best practice.
3. Scored shafts are packing destroyers. If shaft is scored as much as 1/64" deep it should be removed and polished before renewing packing.
4. Packing replacements can best be made with formed rings and these should be inserted with their joints staggered. Do not use a one piece spiral wrap of packing. Care must be exercised in slipping rings over the shaft. Part them as below to avoid deforming.



5. Forming of a new packing in the stuffing box should be done by pulling gland bolts down evenly and firmly. Bolts should then be backed off gradually as stuffing box warms up. Several adjustments with the new packing can be expected before final running condition is attained.



Liberty Pump, Inc.

Liberty Pump Series - Owners Manual

1L2 through 3L8 sizes - Assembly / Disassembly

1. Remove clamp bolts from stator housing support #38, pull top half of stator support #38 from stator #21.
2. By using pipe wrench remove stator #21 from main body casting #2. Pull stator #21 off rotor #22.
3. Remove two drive pin screws #54 with Allen Wrench and drive shaft pin #46 by pushing pin through collar.
4. Slide collar #49 back to packing gland #41.
5. Remove two drive pin washers #73. (It is usually best to use new drive pin washers when re-assembling).
6. Pull rotor #22 out of drive shaft #26.
7. To disassemble rotor and connecting rod, press rotor band #50 off rotor head, push rotor pin #45 out of rotor head, then pull connection rod #25 out of rotor head. To re-assemble rotor and connecting rod, use new connecting rod washers #53 and pack ball joint with water-proof grease.
8. Remove five cap screws from bearing cover plate #34.
9. Insert a small rod into drive shaft #26 through main body casting #1 and drive ball bearing and shaft assembly out of main body casting #2.
10. To dis-assemble drive shaft #26 and ball bearings, remove lock nut #58 and washer #59, then press bearing #29 and #30, also bearing spacer #33 off drive shaft #26. When assembling, bearing should be packed with a good bearing grease to about one-third capacity of bearing housing.
11. Remove packing gland bolts and packing gland #41.
12. Remove packing #42 and note how the packing rings are staggered. When re-packing, stagger ends of packing. Remove lantern ring #57 and packing gland insert #65.
13. Press grease seal retainer #63 out of main body casting #2 and remove radial bearing grease seal #61. Remove thrust bearing grease seal #62 from bearing cover plate #34.
14. To re-assemble, reverse the above procedure.



Liberty Pump, Inc.

Liberty Pump Series - Owners Manual

1L10 through 2L10H sizes - Assembly / Disassembly

1. Remove clamp bolts from stator housing support #38, pull top half of stator support #38 from stator #21.
2. By using pipe wrench remove stator #21 from main body casting #2. Pull stator #21 off rotor #22.
3. Remove two drive pin screws #54 with Allen Wrench and drive shaft pin #46 by pushing pin through drive pin screw holes.
4. Pull rotor #22 out of drive shaft #26.
5. To disassemble rotor and connecting rod, press rotor band #50 off rotor head, push rotor pin #45 out of rotor head, then pull connection rod #25 out of rotor head. To re-assemble rotor and connecting rod, use new connecting rod washers #53 and pack ball joint with water-proof grease.
6. Remove five cap screws from bearing cover plate #34.
7. Insert a rod into drive shaft #26 through main body casting #2 and drive ball bearing and shaft assembly out of main body casting #2.
8. To dis-assemble drive shaft #26 and ball bearings, remove lock nut #58 and washer #59, then press bearing #29 and #30, also bearing spacer #33 off drive shaft #26. When assembling, bearing should be packed with a good bearing grease to about one-third capacity of bearing housing.
9. Remove packing gland bolts and packing gland #41.
10. Remove packing #42 and note how the packing rings are staggered. When re-packing, stagger ends of packing. Remove lantern ring #57 and packing gland insert #65.
11. Press grease seal retainer #63 out of main body casting #2 and remove radial bearing grease seal #61. Remove thrust bearing grease seal #62 from bearing cover plate #34.
12. To re-assemble, reverse the above procedure.



Liberty Pump, Inc.

Liberty Pump Series - Owners Manual

1L12 through 2L12H sizes - Assembly / Disassembly

1. Remove discharge end #9. Remove clamp bolts from stator #38, pull top half of stator support #38 from stator #21.

2. By using pipe wrench remove stator #21 from stator adapter flange #12. Pull stator #21 off rotor #22.

2a. Alternate method: Remove bolts holding stator adapter flange #12 to main body casting. Remove clamp bolts from body housing support #38, pull top half of body housing support from pump body. Raise pump at suction to facilitate removal of stator #21 with stator adapter flange #12 attached. Pull stator #21 off rotor #22.

3. Remove two drive pin screws #54 with Allen Wrench and remove shaft pin #46, under drive pin screws, by pushing pin through collar #49.

4. Slide collar #49 from drive shaft #26.

5. Remove two drive pin washers #73. (It is usually best to use new drive pin washers when re-assembling).

6. Pull rotor and connecting rod assembly out of drive shaft #26.

7. To disassemble rotor and connecting rod, press rotor bands (two) #50 off head #32, push pins #46 out of rotor head, pull connection rod #25 out of rotor head #32, remove "O" ring #110B from rotor, remove connecting rod washers #53 from connecting rod #25. To re-assemble rotor and connecting rod, use new connecting rod washers #53, new "O" ring #110B and pack ball joint with water-proof grease.

8. Remove six cap screws from bearing cover plate #34 and remove cover plate. Remove grease fitting and plug from bearing housing at body support.

9. Insert a small rod into drive shaft #26 through main body casting #2 and #5 and drive bearing assembly #31 and shaft assembly out of joined main body and bearing housing casting.

10. To remove roller bearing assembly #31 from drive shaft #26, remove the Allen head screw and brass slug from bearing lock nut #58 and remove lock nut. Use a piece of tubing approximately 24" long with an inside diameter of 4-13/16" + .015 which is to be placed down over the shaft end against roller bearing cone. With tube in position bearings can be removed from the shaft. If an arbor press is not available use a piece of wood on end of tubing and strike with a heavy sledge hammer.

11. Remove packing gland bolts and packing gland #41.

12. Remove packing #42 and note how the packing rings are staggered. When re-packing, stagger ends of packing. Remove lantern ring #57 and packing washer insert #65.

13. Press bearing housing grease seal #61 and bearing cover plate grease seal #62 out of joined main body and bearing housing castings and bearing cover plate #34 respectively.

14. To re-assemble, reverse the above procedure.



Liberty Pump, Inc.

Liberty Pump Series - Owners Manual

1L2, 2L2, 3L2 sizes – Sectional Drawing

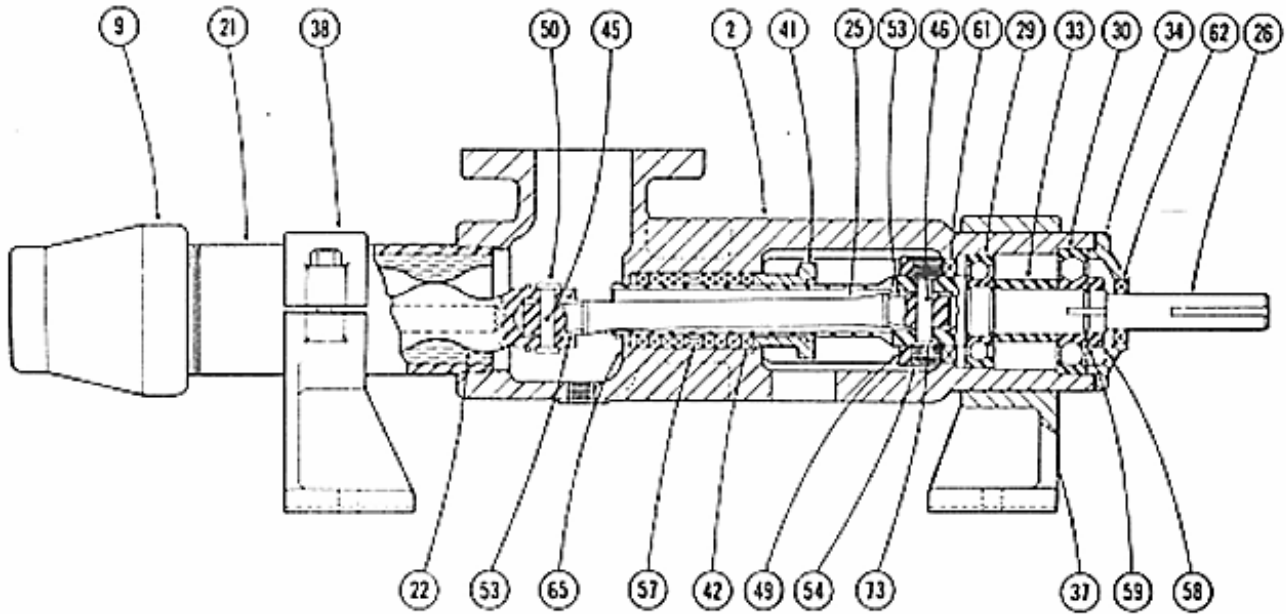

Part No.	Part Name	Part No.	Part Name
2	Suction Body	45	Rotor Pin
9	Reducer	46	Shaft Pin
21	Stator	49	Shaft Collar
22	Rotor	50	Rotor Pin Retainer - Band
25	Connecting Rod	53	Connecting Rod Washers
26	Drive Shaft	54	Drive Pin Retainer Nuts
29	Ball Bearing (Radial)	57	Lantern Ring
30	Ball Bearing (Thrust)	58	Bearing Lock Nut
33	Bearing Spacer	59	Bearing Lock Washer
34	Bearing Cover Plate	61	Grease Seal (Radial)
37	Body Support	62	Grease Seal (Thrust)
38	Stator Support	65	Packing Gland Insert
41	Packing Gland	73	Drive Pin Washers
42	Packing (set)		



Liberty Pump, Inc.

Liberty Pump Series - Owners Manual 1L3 through 3L8 sizes – Sectional Drawing

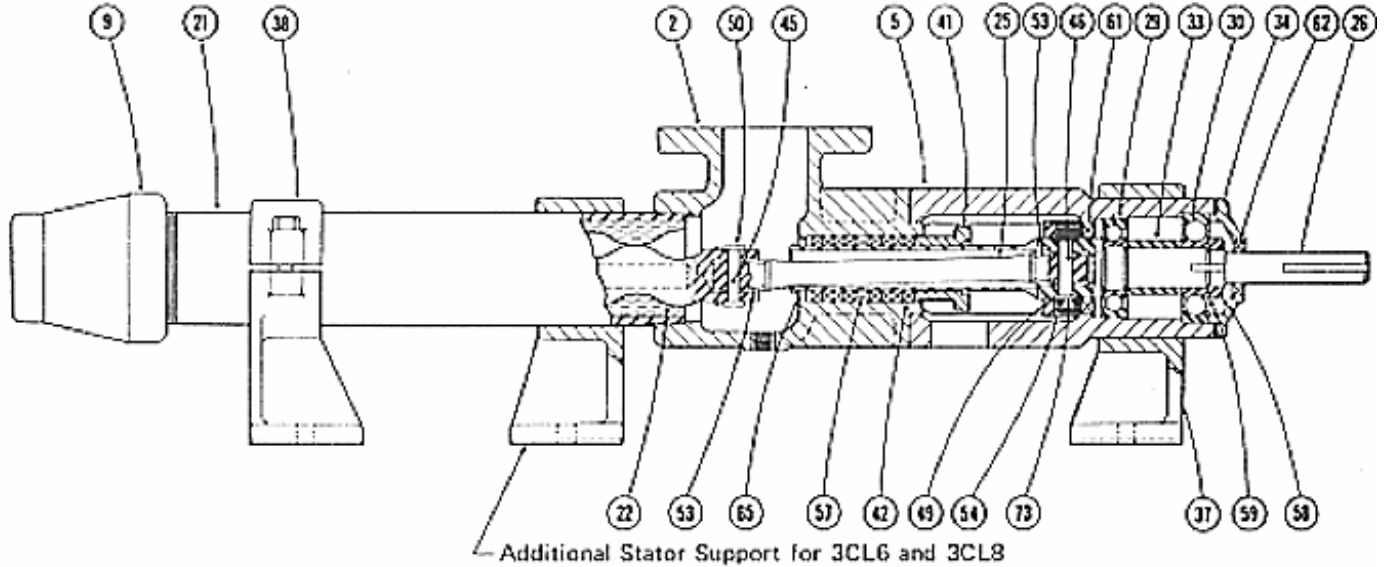

Part No.	Part Name	Part No.	Part Name
2	Suction Body	42	Packing (set)
5	Bearing Housing	45	Rotor Pin
9	Reducer	46	Shaft Pin
21	Stator	49	Shaft Collar
22	Rotor	50	Rotor Band
25	Connecting Rod	53	Connecting Rod Washers
26	Drive Shaft	54	Drive Pin Retainer Screws
29	Ball Bearing (Radial)	57	Lantern Ring
30	Ball Bearing (Thrust)	58	Bearing Lock Nut
33	Bearing Spacer	59	Bearing Lock Washer
34	Bearing Cover Plate	61	Grease Seal (Radial)
37	Pump Support	62	Grease Seal (Thrust)
38	Stator Support	65	Packing Gland Insert
41	Packing Gland	73	Drive Pin Washers



Liberty Pump, Inc.

Liberty Pump Series - Owners Manual 1L10 through 2L10H sizes – Sectional Drawing

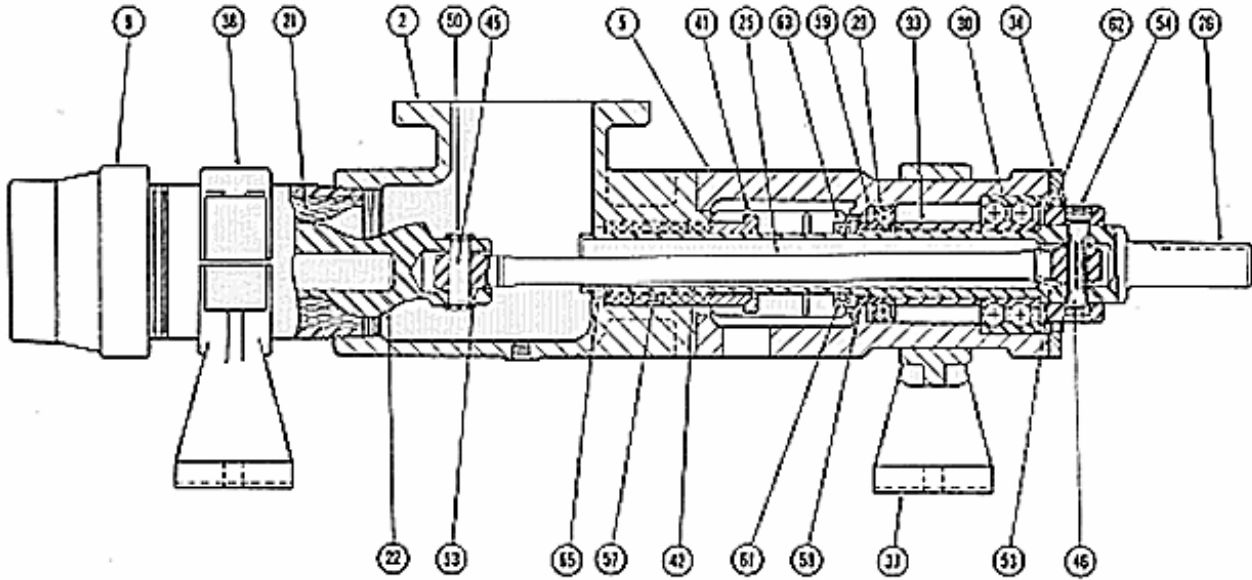

Part No.	Part Name	Part No.	Part Name
2	Suction Body	42	Packing (set)
5	Bearing Housing	45	Rotor Pin
9	Reducer	46	Shaft Pin
21	Stator	50	Rotor Band
22	Rotor	53	Connecting Rod Washers
25	Connecting Rod	54	Drive Pin Retainer Screws
26	Drive Shaft	57	Lantern Ring
29	Ball Bearing (Radial)	58	Bearing Lock Nut
30	Ball Bearing (Thrust)	59	Bearing Lock Washer
33	Bearing Spacer	61	Grease Seal (Radial)
34	Bearing Cover Plate	62	Grease Seal (Thrust)
37	Pump Support	63	Grease Seal Retainer
38	Stator Support	65	Packing Gland Insert
41	Packing Gland		



Liberty Pump, Inc.

Liberty Pump Series - Owners Manual 1L12 through 1L12H sizes – Sectional Drawing

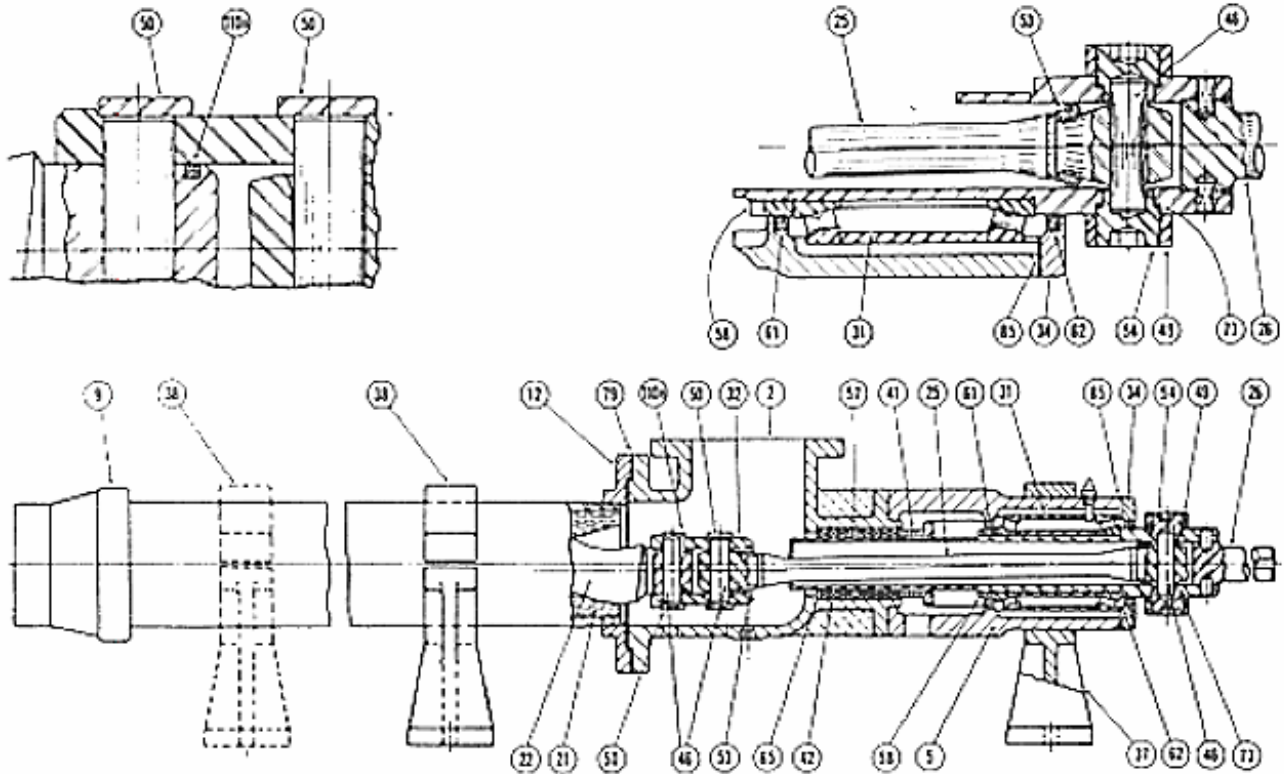

Part No.	Part Name	Part No.	Part Name
2	Suction Body	46	Shaft Pin or Rotor Pin
5	Bearing Housing	49	Shaft Collar
9	Reducer	50	Rotor Band
12	Adapter Flange	53	Connecting Rod Washers
21	Stator	54	Drive Pin Retainer Screws
22	Rotor	57	Lantern Ring
25	Connecting Rod	58	Bearing Lock Nut
26	Drive Shaft	61	Grease Seal (Radial)
31	Roller Bearing Assembly	62	Grease Seal (Thrust)
32	Rotor Head	65	Packing Gland Insert
34	Bearing Cover Plate	73	Drive Pin Washers
37	Pump Support	79	Gasket
38	Stator Support	85	Cover Plate Gasket
41	Packing Gland	110B	"O" Ring (Rotor Head)
42	Packing (set)		



Liberty Pump, Inc.

Liberty Pump Series - Owners Manual 1L2 through 3L6 sizes – Dimensional Drawing

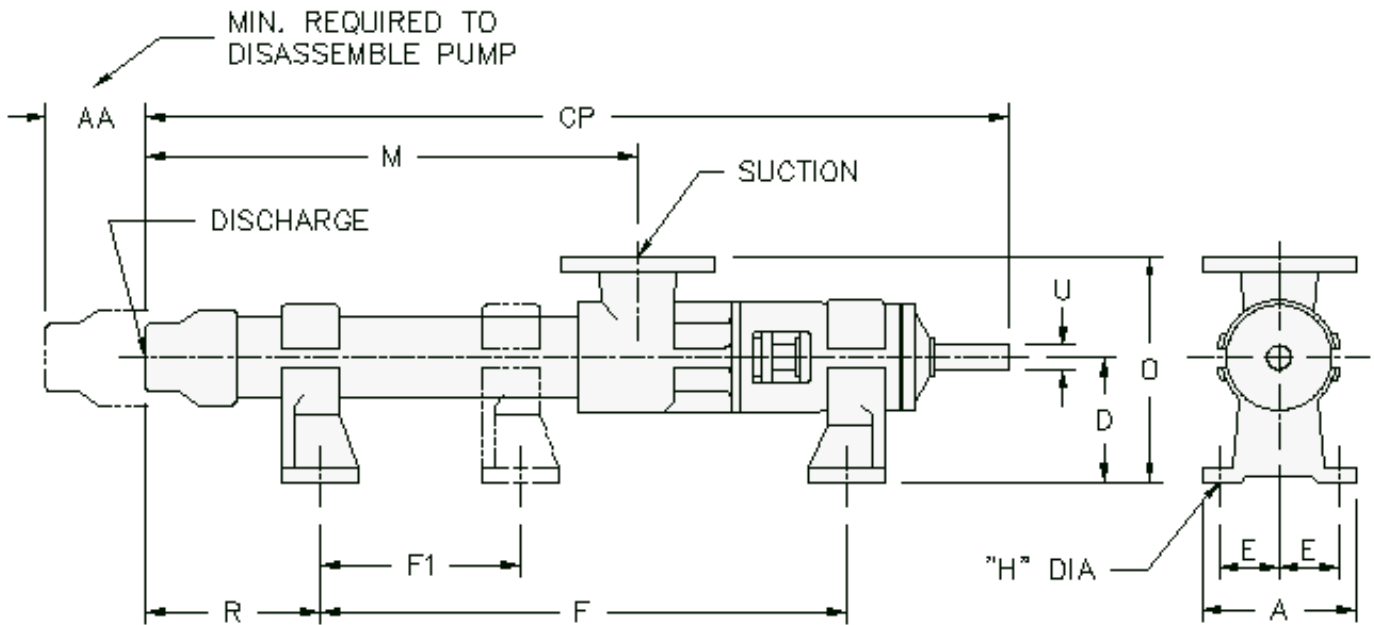

Model No.	AA	CP	A	D	E	F	F1	H	M	O	R	U	Keyway	Suction	Discharge	Weight Lbs.
2M1	6.50	Part	Part	Part	Part	Part	Part	Part	Part	Part	Part	Part	.19x.09	Part	Part	Part
2M1	6.50	Part	Part	Part	Part	Part	Part	Part	Part	Part	Part	Part	.19x.09	Part	Part	Part
2M1	6.50	Part	Part	Part	Part	Part	Part	Part	Part	Part	Part	Part	.19x.09	Part	Part	Part
2M1	6.50	Part	Part	Part	Part	Part	Part	Part	Part	Part	Part	Part	.19x.09	Part	Part	Part
2M1	6.50	Part	Part	Part	Part	Part	Part	Part	Part	Part	Part	Part	.19x.09	Part	Part	Part
2M1	6.50	Part	Part	Part	Part	Part	Part	Part	Part	Part	Part	Part	.19x.09	Part	Part	Part
2M1	6.50	Part	Part	Part	Part	Part	Part	Part	Part	Part	Part	Part	.19x.09	Part	Part	Part
2M1	6.50	Part	Part	Part	Part	Part	Part	Part	Part	Part	Part	Part	.19x.09	Part	Part	Part
2M1	6.50	Part	Part	Part	Part	Part	Part	Part	Part	Part	Part	Part	.19x.09	Part	Part	Part
2M1	6.50	Part	Part	Part	Part	Part	Part	Part	Part	Part	Part	Part	.19x.09	Part	Part	Part
2M1	6.50	Part	Part	Part	Part	Part	Part	Part	Part	Part	Part	Part	.19x.09	Part	Part	Part
2M1	6.50	Part	Part	Part	Part	Part	Part	Part	Part	Part	Part	Part	.19x.09	Part	Part	Part
2M1	6.50	Part	Part	Part	Part	Part	Part	Part	Part	Part	Part	Part	.19x.09	Part	Part	Part
2M1	6.50	Part	Part	Part	Part	Part	Part	Part	Part	Part	Part	Part	.19x.09	Part	Part	Part
2M1	6.50	Part	Part	Part	Part	Part	Part	Part	Part	Part	Part	Part	.19x.09	Part	Part	Part
2M1	6.50	Part	Part	Part	Part	Part	Part	Part	Part	Part	Part	Part	.19x.09	Part	Part	Part
2M1	6.50	Part	Part	Part	Part	Part	Part	Part	Part	Part	Part	Part	.19x.09	Part	Part	Part
2M1	6.50	Part	Part	Part	Part	Part	Part	Part	Part	Part	Part	Part	.19x.09	Part	Part	Part
2M1	6.50	Part	Part	Part	Part	Part	Part	Part	Part	Part	Part	Part	.19x.09	Part	Part	Part



Liberty Pump, Inc.

Liberty Pump Series - Owners Manual 1L12 through 1L12H sizes – Dimensional Drawing

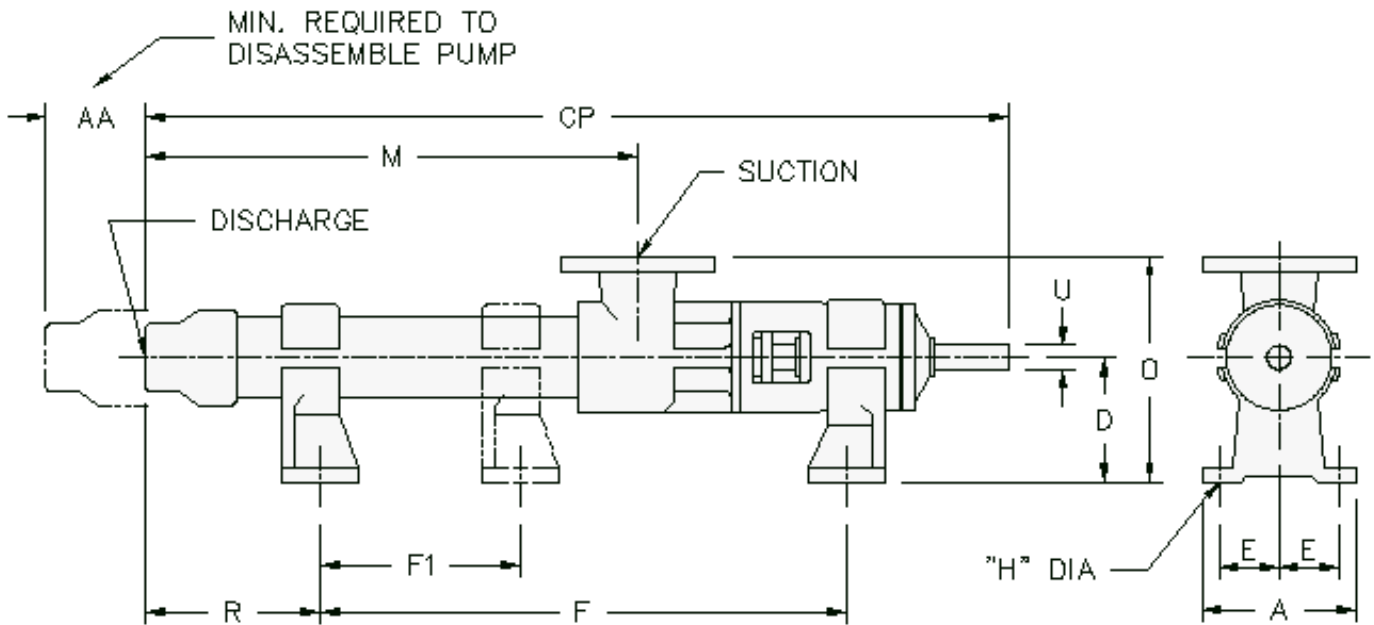

Model No.	AA	CP	A	D	E	F	F1	H	M	O	R	U	Keyway	Suction	Discharge	Weight Lbs.
2M1	6.50	Part	Part	Part	Part	Part	Part	Part	Part	Part	Part	Part	.19x.09	Part	Part	Part
2M1	6.50	Part	Part	Part	Part	Part	Part	Part	Part	Part	Part	Part	.19x.09	Part	Part	Part
2M1	6.50	Part	Part	Part	Part	Part	Part	Part	Part	Part	Part	Part	.19x.09	Part	Part	Part
2M1	6.50	Part	Part	Part	Part	Part	Part	Part	Part	Part	Part	Part	.19x.09	Part	Part	Part
2M1	6.50	Part	Part	Part	Part	Part	Part	Part	Part	Part	Part	Part	.19x.09	Part	Part	Part
2M1	6.50	Part	Part	Part	Part	Part	Part	Part	Part	Part	Part	Part	.19x.09	Part	Part	Part
2M1	6.50	Part	Part	Part	Part	Part	Part	Part	Part	Part	Part	Part	.19x.09	Part	Part	Part
2M1	6.50	Part	Part	Part	Part	Part	Part	Part	Part	Part	Part	Part	.19x.09	Part	Part	Part
2M1	6.50	Part	Part	Part	Part	Part	Part	Part	Part	Part	Part	Part	.19x.09	Part	Part	Part
2M1	6.50	Part	Part	Part	Part	Part	Part	Part	Part	Part	Part	Part	.19x.09	Part	Part	Part
2M1	6.50	Part	Part	Part	Part	Part	Part	Part	Part	Part	Part	Part	.19x.09	Part	Part	Part
2M1	6.50	Part	Part	Part	Part	Part	Part	Part	Part	Part	Part	Part	.19x.09	Part	Part	Part
2M1	6.50	Part	Part	Part	Part	Part	Part	Part	Part	Part	Part	Part	.19x.09	Part	Part	Part
2M1	6.50	Part	Part	Part	Part	Part	Part	Part	Part	Part	Part	Part	.19x.09	Part	Part	Part
2M1	6.50	Part	Part	Part	Part	Part	Part	Part	Part	Part	Part	Part	.19x.09	Part	Part	Part
2M1	6.50	Part	Part	Part	Part	Part	Part	Part	Part	Part	Part	Part	.19x.09	Part	Part	Part
2M1	6.50	Part	Part	Part	Part	Part	Part	Part	Part	Part	Part	Part	.19x.09	Part	Part	Part
2M1	6.50	Part	Part	Part	Part	Part	Part	Part	Part	Part	Part	Part	.19x.09	Part	Part	Part
2M1	6.50	Part	Part	Part	Part	Part	Part	Part	Part	Part	Part	Part	.19x.09	Part	Part	Part
2M1	6.50	Part	Part	Part	Part	Part	Part	Part	Part	Part	Part	Part	.19x.09	Part	Part	Part



Liberty Pump, Inc.

Liberty Pump Series - Owners Manual 2L12 through 3L6 sizes – Performance Data

Frame Size	Gal./100 Rev.	Pump Speed	300 RPM		450 RPM		600 RPM		750 RPM		900 RPM		1200 RPM	
		Diff.Pres.PSI	GPM	HP	GPM	HP	GPM	HP	GPM	HP	GPM	HP	GPM	HP
1L2	.260	0	.54	1/8	1.1	1/6	1.5	1/6	2.0	1/4	2.2	1/4	3.0	1/3
		30	.51	1/8	.95	1/6	1.3	1/6	1.8	1/4	2.1	1/4	2.8	1/3
		60	.40	1/8	.50	1/6	.9	1/6	1.4	1/4	1.7	1/4	2.3	1/3
2L2	.260	0	.54	1/4	1.1	1/4	1.5	1/4	2.0	1/3	2.2	1/3	3.0	1/2
		60	.51	1/4	.95	1/4	1.3	1/4	1.8	1/3	2.1	1/3	2.8	1/2
		120	.50	1/4	.50	1/4	.9	1/4	1.4	1/3	1.7	1/3	2.3	1/2
3L2	.260	0	.54	1/4	1.1	1/4	1.5	1/3	2.0	1/3	2.2	1/3	3.0	3/4
		90	.51	1/4	.95	1/4	1.3	1/3	1.8	1/3	1.7	1/3	2.3	3/4
		180	.50	1/4	.50	1/4	.9	1/3	1.4	1/3	1.7	1/3	2.3	3/4
1L3	.860	0	2.5	1/3	3.8	1/3	5.1	1/3	6.4	1/3	7.5	1/2	10	3/4
		40	1.6	1/3	3.0	1/3	4.3	1/3	5.5	1/2	6.8	1/2	9.3	3/4
		75	-	-	1.5	1/3	2.7	1/3	4.2	1/2	5.0	3/4	7.7	3/4
2L3	.860	0	2.5	1/3	3.8	1/3	5.1	1/2	6.4	1/2	7.5	3/4	10	1
		80	1.6	1/3	3.0	1/3	4.3	1/2	5.5	3/4	6.8	3/4	9.3	1
		150	-	-	1.4	1/3	2.7	1/2	4.2	3/4	5.0	1	7.7	1-1/2
3L3	.860	0	2.5	1/3	3.8	1/2	5.1	3/4	6.4	3/4	7.5	3/4	10	1
		120	1.6	1/3	3.0	1/2	4.3	3/4	5.5	1	6.8	1	9.3	1-1/2
		225	-	-	1.6	3/4	2.7	1	4.2	1-1/2	5.0	1-1/2	7.7	2
1L4	2.02	0	538	1/2	9.0	1/2	2.0	1/2	15	1/2	18	3/4	24	1
		40	4.0	1/2	6.7	1/2	9.5	1/2	12.5	3/4	16	1	22	1
		75	-	-	2.7	3/4	5.5	3/4	8.5	1	12	1-1/2	18	1-1/2
2L4	2.02	0	5.8	3/4	9.0	1/2	12	3/4	15	3/4	18	1	24	1-1/2
		80	4.0	3/4	6.7	3/4	9.5	1	12.5	1-1/2	16	1-1/2	22	2
		150	-	-	2.7	1	5.5	1-1/2	8.5	2	12	2	18	3
3L4	2.02	0	5.0	3/4	9.0	3/4	12.0	1	15	1	18	1-1/2	24	2
		120	4.0	3/4	6.7	1	9.5	1-1/2	12.5	1-1/2	16	2	22	3
		255	2.0	1	3.7	1-1/2	5.5	2	8.5	3	12	3	18	5
1L6	5.20	0	15	1	23	1	31	1-1/2	39	1-1/2	47	2		
		40	11	1	19	1	27	1-1/2	35	2	43	2		
		75	6.5	1	13	1-1/2	21	2	28	3	36	3		
2L6	5.20	0	15	1	23	1-1/2	31	2	39	2	47	3		
		80	11	1	19	1-1/2	27	2	35	3	43	3		
		150	5	2	13	3	21	5	28	5	36	5		
3L6	5.20	0	15	1-1/2	23	2	31	3	39	3	47	5		
		120	11	1-1/2	19	3	27	3	35	5	43	5		
		225	5	3	13	5	21	5	28	7-1/2	36	7-1/2		



Liberty Pump, Inc.

Liberty Pump Series - Owners Manual 1L8 through 2L12H sizes – Performance Data

Frame Size	Gal./100 Rev.	Pump Speed	300 RPM		450 RPM		600 RPM		750 RPM		900 RPM	
		Diff.Pres.PSI	GPM	HP	GPM	HP	GPM	HP	GPM	HP	GPM	HP
1L8	11.7	0	33	2	51	2	68	3	87	3	100	5
		40	27	2	45	2	62	3	76	5	94	5
		75	17	2	35	3	52	5	66	7-1/2	84	7-1/2
2L8	11.7	0	33	3	51	3	68	5	87	5	100	7-1/2
		80	27	3	45	5	62	5	76	7-1/2	94	7-1/2
		150	18	5	35	7-1/2	52	7-1/2	66	10	84	10
3L8	11.7	0	33	5	51	5	68	7-1/2	87	7-1/2	100	10
		120	27	5	45	5	62	7-1/2	76	10	94	10
		225	18	7-1/2	35	10	52	10	66	15	84	15
1L10	18.8	0	56	2	84	3	115	5	140	5		
		40	46	2	74	3	105	5	130	7-1/2		
		75	26	5	53	5	84	7-1/2	106	10		
2L10	18.8	0	56	3	84	5	115	7-1/2	140	7-1/2		
		80	46	5	74	7-1/2	105	7-1/2	130	10		
		150	24	7-1/2	53	10	84	15	106	20		
3L10	18.8	0	56	5	84	7-1/2	115	10	140	10		
		120	46	5	74	10	105	10	130	15		
		225	22	10	53	15	84	20	106	25		
1L10H	27.7	0	83	3	127	5	168	7-1/2	210	7-1/2		
		40	73	3	117	5	158	7-1/2	202	10		
		75	55	5	100	7-1/2	143	10	187	15		
2L10H	27.7	0	83	5	127	7-1/2	168	10	210	10		
		80	73	5	117	7-1/2	158	10	202	15		
		150	64	10	100	15	143	20	187	25		
1L12	43.5	0	130	5	196	7-1/2	255	10				
		40	118	7-1/2	184	10	240	15				
		75	85	10	149	15	210	20				
2L12	43.5	0	130	10	196	15	255	20				
		80	118	10	184	15	240	20				
3L12	43.5	150	85	15	149	25	208	30				
		0	130	15	196	20	255	25				
		120	118	15	184	20	240	25				
		225	85	25	149	30	210	40				