



Liberty Process Equipment, Inc.

American Pump Series - Owners Manual

AP - Operation & Assembly

Speed, temperature, viscosity, suction lift, discharge pressure, abrasive content and corrosive action of the liquid to be handled should all be considered in applying these pumps. Pump should always be filled with the liquid to be handled before running. The liquid serves as a lubricant and is easily poured into pump through the discharge port before final assembly of the piping or hose connections. A filling tee with a plug or valve can be installed above the discharge port for ease in filling.

Liquid to be pumped should never exceed 190°F temperature. Maximum speed that any of these pumps should be run is 2,800 rpm and then only in handling thin, abrasive-free liquids. Preferably the speed should be 1,750 rpm for longest life. When liquid contains abrasive material or is viscous, the speed should be reduced.

For various viscosities of abrasive-free liquids, the maximum operating speed of the pump is set forth below:

SUGGESTED MAXIMUM OPERATING SPEED OF PUMP							
2800 RPM	1750 rpm	1150 RPM	870 RPM	580 RPM	430 RPM	180 RPM	100 RPM
VISCOSITY (Centipoise)							
1	1 to 100	100 to 500	500 to 1000	1000 to 3000	3000 to 5000	5000 to 10,000	10,000 to 20,000
Water	Canned Milk	Motor Oil	Table Syrup	Honey	Molasses	Paste	Peanut Butter
ABRASIVE FLUIDS							
None	None	None	Light	Medium	Medium	Heavy	Heavy
Clear Water Gasoline		Dirty Water		Clay Slurries		Lapping Compounds	

Capacity and life of these pumps will depend upon the liquid being handled. Piping to pump should be properly selected and should not be smaller in size than the suction and discharge ports of the pump. All pipe and hose fitting joints should be tight. Discharge lines should be open or if pump is operated in an enclosed system, provision should be made for pressure relief when the pump pressure exceeds the limits as set forth for each model pump. Pump bearings do not require lubrication as they are pre-lubricated. We recommend that the pump be flushed after its use. **PUMP SHOULD NOT BE RUN DRY.**

When necessary to dismantle pump, disconnect pipe or hose at suction and discharge ports. Remove bolts which connect Suction Housing to Discharge Housing. Rotor can be removed by turning it in opposite direction to pump rotation. Grip Rotor with wrench, whose teeth have been protected, and hold Shaft externally-hold Motor Shaft with Screwdriver on 'M Models. To replace Rotary Seal, unscrew Flexible Joint with 3/16" hexagonal wrench. Rotary Seals can be easily removed from shaft.

To replace Pump Bearings remove Retaining Ring and then tap shaft at threaded end. Protect threaded end with wood or rubber block. If any parts of the Rotary Seal are worn or broken, replace complete Rotary Seal. The parts of each Rotary Seal are precision matched and are not interchangeable. Illustration below shows how Rotary Seal is installed by parts and how it looks after it is complete. Part A is pressed into the Discharge Housing. Care should be taken to assure that rubbing surfaces of Part A and B are not scratched. Moisten rubber sleeve of Part B with water to permit easy fitting over Shaft. Part B is then slipped down Shaft until face fits firmly against face of Part A. Part C is placed against Part B. Flexible Joint should then be screwed into Shaft against Part C. Use hexagonal wrench to tighten Flexible Joint, then screw Rotor onto Flexible Joint. It is not necessary to tighten Rotor with a wrench as it is self-tightening when pump starts. Moisten inside of Stator with water and slip it over Rotor. Mount Suction Housing to Discharge Housing and fasten with body screws. Refill pump with liquid to be handled, connect pipe or hose to suction and discharge ports and pump is ready to run.

ROTARY SEAL ASSEMBLY

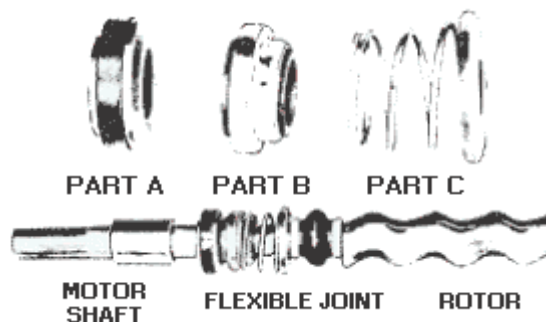



Liberty Process Equipment, Inc.

AP – Sectional Drawing

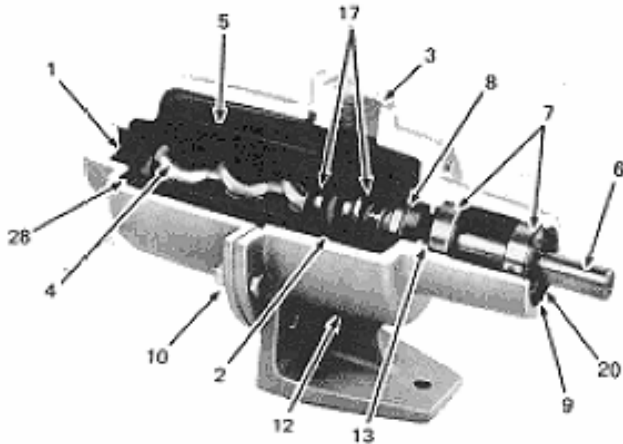

Mechanical Seal Types

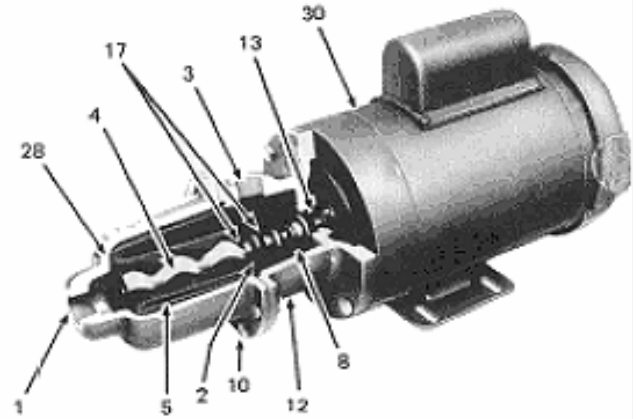

Closed-Coupled Types

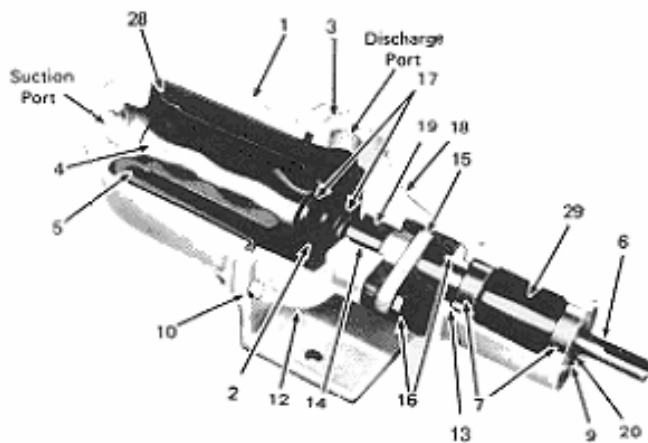

Packing Gland Types

Materials Nomenclature

B - Butyl/EPDM	P - Pinned Connection
C - Cast Iron	Q - Buna N/Nitrile
CC - Closed-Coupled	M - Mech. Seal
PG - Packing Gland	S - Stainless
F - Viton	T - Threaded

Part No.	Part Name	Part No.	Part Name	Part No.	Part Name
1	Suction Body	9	Retaining Ring	18	Grease Fitting
2	Flexible Joint	10	Screws and Nuts	19	Lantern Ring
3	Discharge Housing	12	Drain Plug	20	Shaft Retaining Ring
4	Rotor	13	Slinger Ring	28	Stator Ring
5	Stator	14	Packing	29	Bearing Spacer
6	Shaft	15	Packing Gland	30	Motor
7	Pump Bearings	16	Packing Gland Bolt		
8	Rotary Seal	17	Roll Pins		



Liberty Process Equipment, Inc.

American Pump Series - Owners Manual

AP – Dimensional Drawing

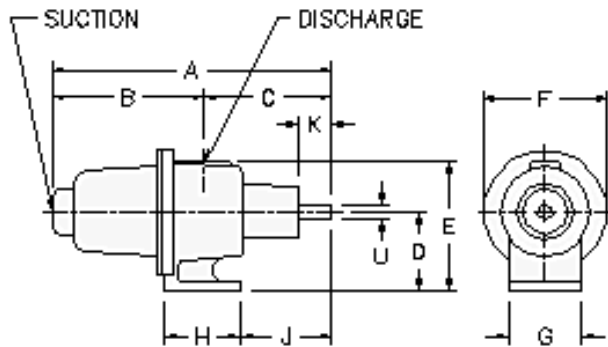

**AP-15M through AP-67M
MECHANICAL SEAL**

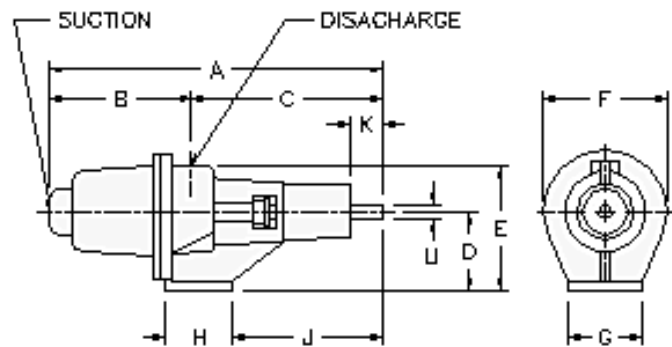

**AP-15D through AP-67D
PACKING**

Dimensions In Inches

MODEL NO.	A	B	C	D	E	F	G	H	J	K	U	SUCT NPT	DISC NPT
AP-15M thru AP-44M	12.40	6.00	5.63	3.50	5.75	5.50	3.25	3.38	3.12	1.46	.62	3/4"	3/4"
AP-15D thru AP-44D	14.75	6.25	8.50	3.50	5.03	5.50	3.25	3.00	6.03	1.46	.62	3/4"	3/4"
AP-56M	16.03	9.75	6.00	4.00	7.00	7.50	6.00	4.75	3.03	2.40	.75	1-1/2"	1-1/4"
AP-56D	18.03	9.75	9.00	7.94	7.00	7.50	6.00	4.75	5.03	2.40	.75	1-1/2"	1-1/4"
AP-67M	19.00	11.00	7.60	4.50	8.25	8.25	6.00	4.09	4.00	2.12	1.00	2"	2"
AP-67D	22.00	12.00	10.00	4.50	8.25	8.25	6.00	4.75	7.09	2.12	1.00	2"	2"



Liberty Process Equipment, Inc.

American Pump Series - Owners Manual

APM – Dimensional Sheet

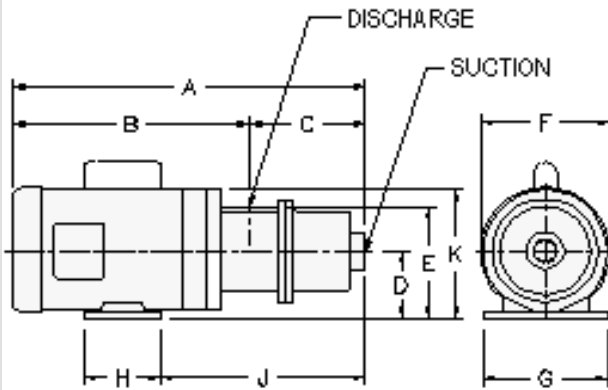

**APM-15 through APM-44
APML-15 through APML-44**

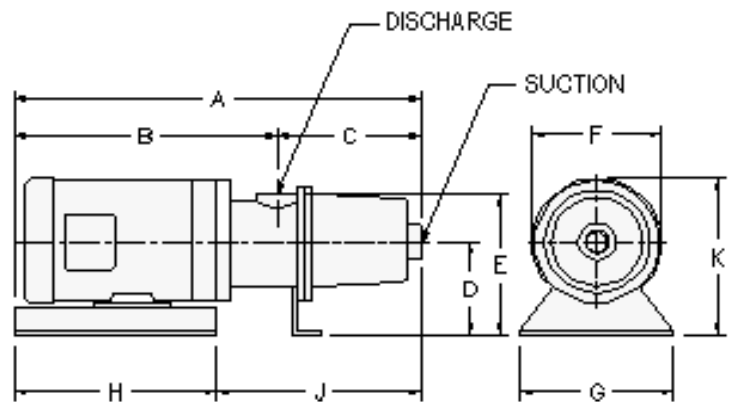

APM-56, APML-56, APM-67, APML-67

Dimensions In Inches

MODEL NO.	A	B	C	D	E	F	G	H	J	K	U	SUCT NPT	DISC NPT
APM-15 thru APM-44	18.30	11.50	6.03	3.50	5.87	6.25	6.50	4.00	10.62	7.00	-	3/4"	3/4"
APML-15 thru APML-44	20.35	13.75	6.03	3.50	5.87	6.25	6.56	4.00	12.87	7.00	-	3/4"	3/4"
APM-56	22.25	12.50	9.75	4.50	7.50	7.50	9.00	10.00	8.31	2.00	-	1-1/2"	1-1/4"
APML-56	24.00	14.00	9.75	4.50	7.50	7.50	9.00	10.00	14.00	2.00	-	1-1/2"	1-1/4"
APM-67	24.62	12.81	12.00	4.50	7.50	8.25	9.00	10.00	14.56	8.12	-	2"	2"
APML-67	27.00	15.03	12.00	4.50	7.50	8.25	9.00	10.00	17.00	8.12	-	2"	2"



Liberty Process Equipment, Inc.

American Pump Series - Owners Manual

P – Performance Data

Model No.	Discharge Pressure	Capacity - GPM (Water at 70 F)					Motor HP
		1750 rpm	1150 rpm	870 rpm	580 rpm	430 rpm	
AP-15	0	1.9	1.3	1.0	.7	.5	½
	25	1.7	1.0	.5	.2	.1	
	50	1.5	.9	.2			
	75	1.2	.8				
	100	1.0	.7				
	125	.8	.5				
	150	.6	.4				
AP-22	0	4.9	3.2	2.4	1.6	1.2	½
	25	4.1	2.7	2.0	1.3	.9	
	50	1.9	2.2	1.6	1.0	.7	
	75	2.6	1.7	1.3	.8	.6	
	100	2.0	1.5	1.0	.6	.4	
AP-33	0	9.4	6.0	4.6	3.1	2.3	½
	25	7.0	4.5	3.4	2.3	1.7	
	50	4.2	2.7	2.0	1.3	.9	
AP-44	0	15.0	9.7	7.3	4.9	3.6	½
	25	12.0	7.8	5.9	4.0	3.0	
	50	9.4	6.1	4.6	3.1	2.3	¾
AP-56	0	24.0	15.6	11.7	7.9	5.8	1
	25	22.0	14.3	10.7	7.2	5.3	
	35	20.5	13.3	10.0	6.7	4.9	
	50	19.5	12.7	9.5	6.4	4.1	
AP-67	0	53.0	34.5	26.0	17.5	13.0	1
	10	48.0	31.0	23.4	15.8	11.7	
	20	43.0	28.0	21.0	14.0	10.3	
	35	34.0	22.0	16.5	11.0	8.1	1-½
	50	25.0	16.3	12.3	8.3	6.1	1