

CM90 - HEAVY-DUTY CIRCULATION PUMP

FEATURES & BENEFITS

- Maximum flow of 17.2 or 30 GPM @ 1.5 psi (65 or 115 l/min @ 0.1 bar)
- Designed for liquid temperatures of -40 °F to +212 °F (-40°C to +100°C)
- Ambient operational temperature range: -40°F till +194°F (-40°C to +90°C)
- Seal-less magnetic drive
- Specifically engineered for continuous operation
- Extended service life
- Ball bearing brush motor - Enclosure IP67
- Equipped with heat flanges for improved cooling
- Steel motor housing
- 12V or 24V motors
- Thermal overload protection
- Universal mounting bracket
- Industry standard ports
- Complies with Recreational Craft Directive 94/25/EEC: (ISO 8846), (ISO 10133)
- Complies with Electromagnetic Compatibility Directive 2004/108/EC: (EN55014-1: 2006), (EN55014-2: 1997 +A1: 2001), (EN61000-6-3: 2007 + A1: 2011)

Electrically powered, centrifugal pump with magnetic transmission

The CM90 circulation pump has been developed primarily for heating and cooling applications in buses, trains and boats, but it is much more. In closed systems or wherever else self-priming is not required, the CM90 is an all-round pump that distinguishes itself for its dependability, capacity and long service life.

The CM90 pump has a magnetic drive, which means that no shaft seal is necessary, as the motor shaft does not penetrate the pump house. With no mechanical seal, longer service life is assured.

Heat flanges on both the motor and the pump also increase service life as they dissipate heat from the unit, which can pump liquids efficiently at a very wide range of temperatures. The CM90 also features integral thermal overload protection and is EMC approved according to EN 55014 standards.

The CM90 magnetic driven centrifugal pump combines a high flow rate with very low electricity consumption, making it ideal for vehicular heating and cooling systems.



CM90

TECHNICAL SPECIFICATIONS

CM90 GENERAL INFORMATION

CAPACITY	¾" port (20 mm)	17.2 GPM (65 l/min) at 1.5 psi (0.1 bar)
	1 ½" port (38 mm)	30.4 GPM (115 l/min) at 1.5 psi (0.1 bar)
SYSTEM PRESSURE	-3 to + 36 psi (-0.2 to +2.5 bar); stationary max. 58 psi (4.0 bar)	
LIQUID	Water/glycol mixture; max. 60% glycol	
MOTOR SERVICE LIFE	10,000 hours at nominal voltage (and 86°F (30°C) ambient temperature) 10,000 start/stops. Interchangeable motor.	
MOTOR VOLTAGE	Nominal 13.6V DC for use between 10-16V Nominal 27.2V DC for use between 20-32V	
INPUT POWER	Max. 125 W	
DRY RUNNING	30 minutes	
PORTS	¾" (20 mm) or 1 ½" (38 mm) diameter	
WEIGHT	6.6 lb (3.0 kg)	
BODY	PPA, fiberglass reinforced	
MOUNTING	Separate universal bracket for flat surfaces	

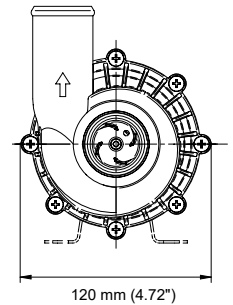
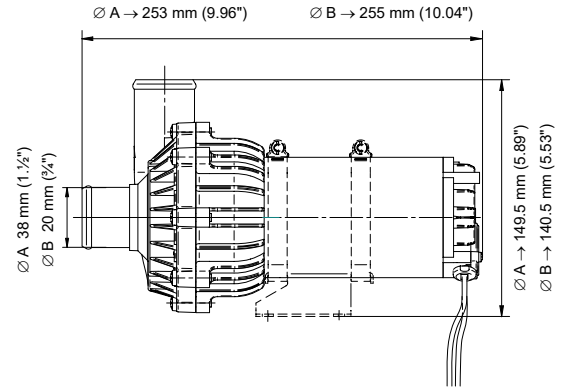

Directives:

Recreational Craft Directive 94/25/EEC
(ISO 8846), (ISO 10133)

Electromagnetic Compatibility Directive 2004/108/EC
(EN5501 4-1: 2006), (EN55014-2: 1997 +A1: 2001),
(EN61000-6-3: 2007 + A1: 2011)

CM90 Pressure and capacity data Based on water at 68°F (20°C) and recommended hose))

HOSE CONNECTION	BACK PRESSURE			FLOW		AMPERAGE	
	BAR	kPA	FT _{H₂O}	L/MIN	GPM	(13.6V)	(27.2V)
1 ½" (Ø 38 mm)	0.1	10	3.4	115	30.4	10	4.6
	0.25	25	8.4	85	22.5	9.5	4.5
	0.4	40	13.4	40	10.6	9	4.2
¾" (Ø 20 mm)	0.1	10	3.4	65	17.2	8.5	4
	0.25	25	8.4	50	13.2	8	3.8
	0.4	40	13.4	30	7.9	7.5	3.6

Recommended Fuse Size:
12 (13.6V), 6 (27.2V)

DESCRIPTION	WITH UNIVERSAL BRACKET
CM90P7-1 13.6V D IA 38 CM90P7-1 27.2V D IA 38	10-24664-09 10-24664-10
CM90P7-1 13.6V D IA 20 CM90P7-1 27.2V D IA 20	10-24750-09 10-24750-10



SPX FLOW, Inc. reserves the right to incorporate our latest design and material changes without notice or obligation. Design features, materials of construction and dimensional data, as described in this bulletin, are provided for your information only and should not be relied upon unless confirmed in writing. Please contact your local sales representative for product availability in your region. The green "➤" is a trademark of SPX FLOW, Inc.

For more information, visit www.johnsonpumpmarine.com