

CM100HP - HIGH PRESSURE CIRCULATION PUMP

FEATURES	BENEFITS	COMPETITIVE ADVANTAGES
Wide Operating Temperature Range	Designed for ambient temperatures of -40°C to +105°C at a liquid temperature of +93°C (-40°F to +220°F at a liquid temp of +200°F)	Reliable operation even under extreme conditions
Automatic Security Protection	Designed with built-in protection for Low Voltage, Reverse Polarity, Dry Run, Voltage Transients and Locked Rotor	Pump protection even when exposed to adverse conditions
Variable Speed Control	Pump able to operate at duty cycles of 10% to 100%	Variable speed control allows adjustment to specific speed control need of application. Also equipped with derating feature that automatically reduces speed
Long Service Life	Designed for continuous duty	Motor designed for 40,000 hours service life
Magnetic Drive	Low maintenance requirement	Eliminates the risk of leakage common with mechanical seals in shaft driven pumps
Enclosure: IP6K9K and IP67	Waterproof design in extreme conditions	Operation in extreme weather and cleaning conditions.



CM100HP

TECHNICAL SPECIFICATIONS

CM100HP GENERAL INFORMATION

CAPACITY	25 mm (1") port	85 l/min (22.5 GPM) at 1 bar (33.5 ft H ₂ O)
	38 mm (1 1/2") port	85 l/min (22.5 GPM) at 1 bar (33.5 ft H ₂ O)
SYSTEM PRESSURE	-0.2 to +2.5 bar (-3 to + 36 psi) at +100°C (+212°F)	
LIQUID	Water/glycol mixture; max. 60% glycol	
MOTOR SERVICE LIFE	The motor is designed for a service life of 40,000 hours at nominal voltage and ambient temperature of +40°C (+104°F)	
MOTOR, VOLTAGE	Nominal 27.2 V DC for use between 16-32 V DC	
MOTOR	Enclosed (as per IP6K9K and IP67) permanent magnet, ball bearing mounted brushless motor, designed for continuous operation	
INPUT POWER	Max. 475 W	
DRY RUNNING	Max. 25 minutes	
PORTS	25 mm (1") or 38 mm (1 1/2") diameter	
WEIGHT	3.9 kg (8.5 lbs)	
PUMP HOUSING	Aluminum, black anodized	
IMPELLER	PPS GF	
INTERMEDIATE PART	PPA GF	
MOUNTING	Separate universal bracket for flat surfaces. Pump is adjustable in bracket for universal application.	
FLAMMABILITY	UL94 Class V0 (external polymer materials meet same requirements)	
DEGREE OF PROTECTION	IP6K9K, IP67 (ISO 20653)	

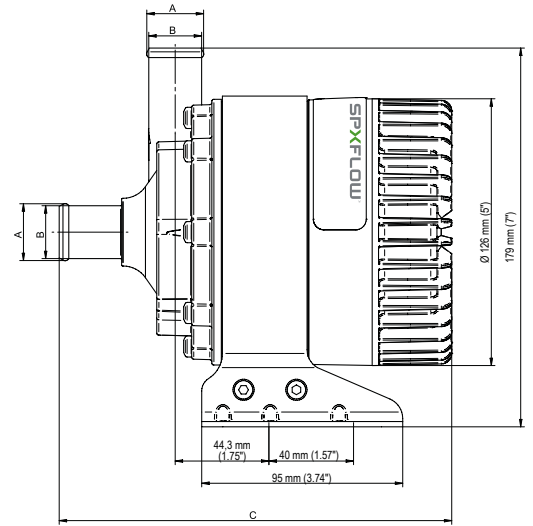

	A	B	C
CM100HP AL-1BL 27,2VC Pump Ø25	1" (26.9 mm)	1" (25 mm)	7.3" (186 mm)
CM100HP AL-1BL 27,2VC Pump Ø38	1.5" (39.9 mm)	1.5" (38 mm)	7.5" (191 mm)

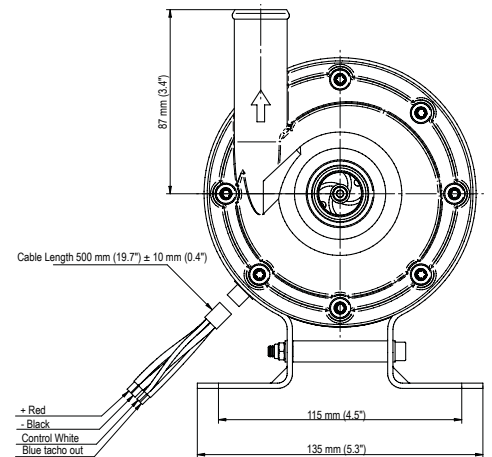

EMC approved according to:

UN ECE R10 rev. 5, with references to CISPR 12, CISPR 25, ISO 11452-2, -3, -4, -5 and ISO 7637.
 EN61000-6-3:2007 + A1:2011, +AC:2012 Class B.
 EN 61000-6-2:2005 + AC: 2005 Industrial.
 EN 60945:2002 Marine, Chapter 9 and 10.
 EN 55014-1:2006 + A1:2009 + A2: 2011.
 EN55014-2:1997 + A1:2001 + A2: 2008 + AC: 1997.

CM100HP Pressure and capacity data (based on water at 20°C /68°F (and recommended hose diameter))

HOSE CONNECTION	BACK PRESSURE			FLOW		AMPERAGE (27.2V) Recommended Fuse Size: 25 – 30A
	BAR	kPA	FT H ₂ O	L/MIN	GPM	
Ø25 mm (1") Ø38 mm (1 1/2")	0.6	60	20.07	104	27.5	16.4
	0.1	100	33.46	85	22.5	16.4
	1.4	140	46.84	57	15.1	16

PART NUMBER	DESCRIPTION
10-13576-02	CM100H P AL-1B L 27,2V D25
10-13577-02	CM100H P AL-1B L 27,2V D38

SPXFLOW®

SPX FLOW, Inc. reserves the right to incorporate our latest design and material changes without notice or obligation. Design features, materials of construction and dimensional data, as described in this bulletin, are provided for your information only and should not be relied upon unless confirmed in writing. Please contact your local sales representative for product availability in your region. The green "S" is a trademark of SPX FLOW, Inc.

For more information, visit www.johnsonpumpmarine.com

©2024 SPX FLOW, Inc.
 JPM_CM100HP_FLR_GB

Version: 09/2024