

CM100HF - HIGH FLOW CIRCULATION PUMP

FEATURES	BENEFITS	COMPETITIVE ADVANTAGES
Wide Operating Temperature Range	Designed for ambient temperatures of -40°F to +220°F at a liquid temp of +200°F (-40°C to +105°C at a liquid temperature of +93°C)	Reliable operation even under extreme conditions
Automatic Security Protection	Designed with built-in protection for Low Voltage, Reverse Polarity, Dry Run, Voltage Transients and Locked Rotor	Pump protection even when exposed to adverse conditions
Variable Speed Control	Pump able to operate at duty cycles of 10% to 100%	Variable speed control allows adjustment to specific speed control need of application. Also equipped with derating feature that automatically reduces speed
Long Service Life	Designed for continuous duty	Motor designed for 40,000 hours service life
Magnetic Drive	Low maintenance requirement	Eliminates the risk of leakage common with mechanical seals in shaft driven pumps
Enclosure: IP6K9K and IP67	Waterproof design in extreme conditions	Operation in extreme weather and cleaning conditions.



CM100HF

TECHNICAL SPECIFICATIONS

CM100HF GENERAL INFORMATION

CAPACITY	1 1/2" (38 mm) port: 35.6 GPM (135 l/min) at 13.38 ft H ₂ O (0.4 bar)
SYSTEM PRESSURE	-3 to + 36 psi (-0.2 to +2.5 bar) at +212°F (+100°C)
MOTOR SERVICE LIFE	The motor is designed for a service life of 40,000 hours at nominal voltage and ambient temperature of +104°F (+40°C)
MOTOR, VOLTAGE	Nominal 27.2 V DC for use between 16-32 V DC
MOTOR	Enclosed (as per IP6K9K and IP67) permanent magnet, ball bearing mounted brushless motor, designed for continuous operation
INPUT POWER	Max. 410 W
DRY RUNNING	Max. 25 minutes
PORTS	1 1/2" (38 mm) diameter
WEIGHT	8.5 lbs (3.9 kg)
PUMP HOUSING	Aluminum, black anodized
IMPELLER	PA12 GF
INTERMEDIATE PART	PPA GF
MOUNTING	Separate universal bracket for flat surfaces
FLAMMABILITY	UL94 Class V0 (external polymer materials meet same requirements)
DEGREE OF PROTECTION	IP6K9K, IP67 (ISO 20653)

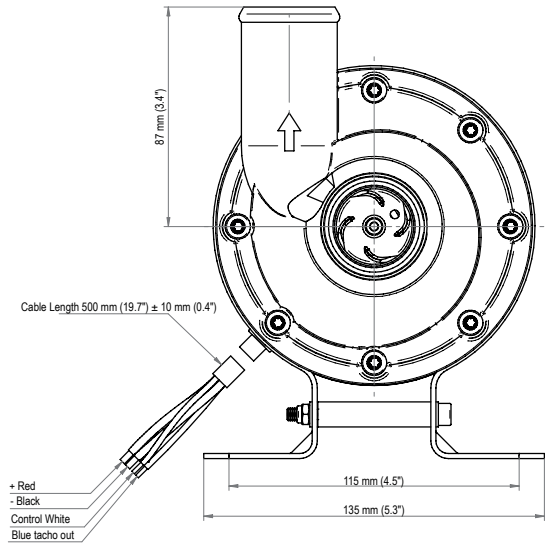
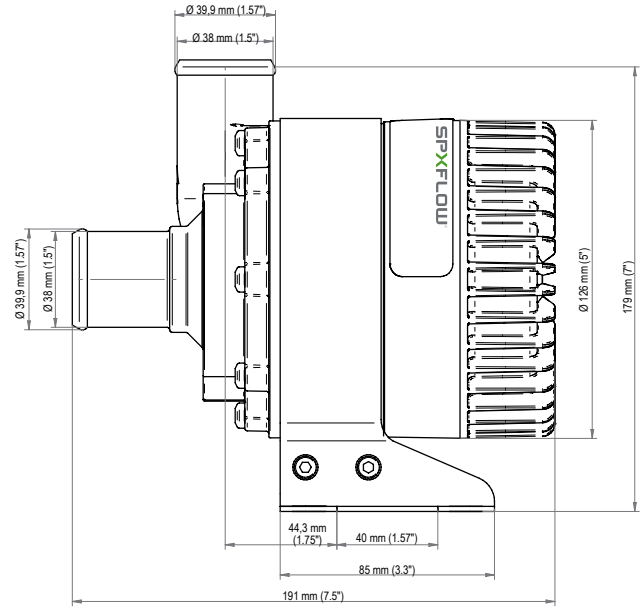

EMC approved according to:

- UN ECE R10 rev. 5, with references to CISPR 12, CISPR 25, ISO 11452-2, -3, -4, -5 and ISO 7637.
- EN61000-6-3:2007 + A1:2011, +AC:2012 Class B.
- EN 61000-6-2:2005 + AC: 2005 Industrial.
- EN 60945:2002 Marine, Chapter 9 and 10.
- EN 55014-1:2006 + A1:2009 + A2: 2011.

CM100HF Pressure and capacity data (based on water at 68°F (20°C) (and recommended hose diameter))

HOSE CONNECTION	BACK PRESSURE			FLOW		AMPERAGE (27.2V)
	BAR	kPA	FTH ₂ O	L/MIN	GPM	
1 1/2" (Ø 38 mm)	0.2	20	6.69	164	43.3	14.9
	0.4	40	13.38	135	35.6	14.8
	0.6	60	20.07	108	28.5	14.5

PART NUMBER	DESCRIPTION
10-13578-02L	CM100H F AL-1B L 27,2V D3820 kPA

Recommended Fuse Size: 25 – 30A



SPX FLOW, Inc. reserves the right to incorporate our latest design and material changes without notice or obligation. Design features, materials of construction and dimensional data, as described in this bulletin, are provided for your information only and should not be relied upon unless confirmed in writing. Please contact your local sales representative for product availability in your region. The green "➤" is a trademark of SPX FLOW, Inc.

For more information, visit www.johnsonpumpmarine.com