

CUSTOMER DETAILS

OEM PUMP PART NO	
MANUFACTURER	ONAN CORP
ENGINE	5.0 MDKOB, 5.5 MDKUB, 6.0 MDKOB, 6.5 MDKUB, 7.5 MDKOB, 9.0 MDKOB
PUMP DESCRIPTION	F35B-9 IMPELLER PUMP OEM

PART LIST

DRAWING POSITION	COMPONENTS	COMPONENT DESCRIPTION	QTY	IMPELLER KIT	WEAR KIT	SHAFT KIT	SCREW KIT
1	01-36525-3	PUMP BODY F35B-9	1				
2	01-45751	SHAFT	1			X	
3	08-808B-1	IMPELLER F35 MC 97	1	09-808B-1			
4	01-42910	CAM 1/1 F35B	1		X		
5	01-47761-1	END COVER F35B	1		X		
6	01-43240	GASKET F35B-	1	09-808B-1	X		
7	01-46676	WEAR PLATE F35B-	1		X		
8	01-42400	PIN F35B-/F7B/F70B	1		X		
9	01-46794-03	SCREW 8-32UNCX8	1		X		
10	0.0141.700	SCREW M4X8 ISO1207	4		X		
12	01-46790-01	WASHER D7.5XD4X1 CU	1		X		
13	0.2233.010	LIP SEAL 12X24X7 DPSM	2		X	X	
14	0.3431.748	BALL BEARING 6001-2RS1	2			X	
15	0.0371.028	RETAIN. RING BORE D28 DIN472 SPRST	1			X	
16	0.2173.468	O-RING 32.1X1.6 SS1586 NBR70	1			X	
17	01-43238	CLAMP F35/F4B-9	2			X	
18	01-45955	WASHER F35/F4B-9	1		X		
19	01-47826-2	MARKING TAG	1				

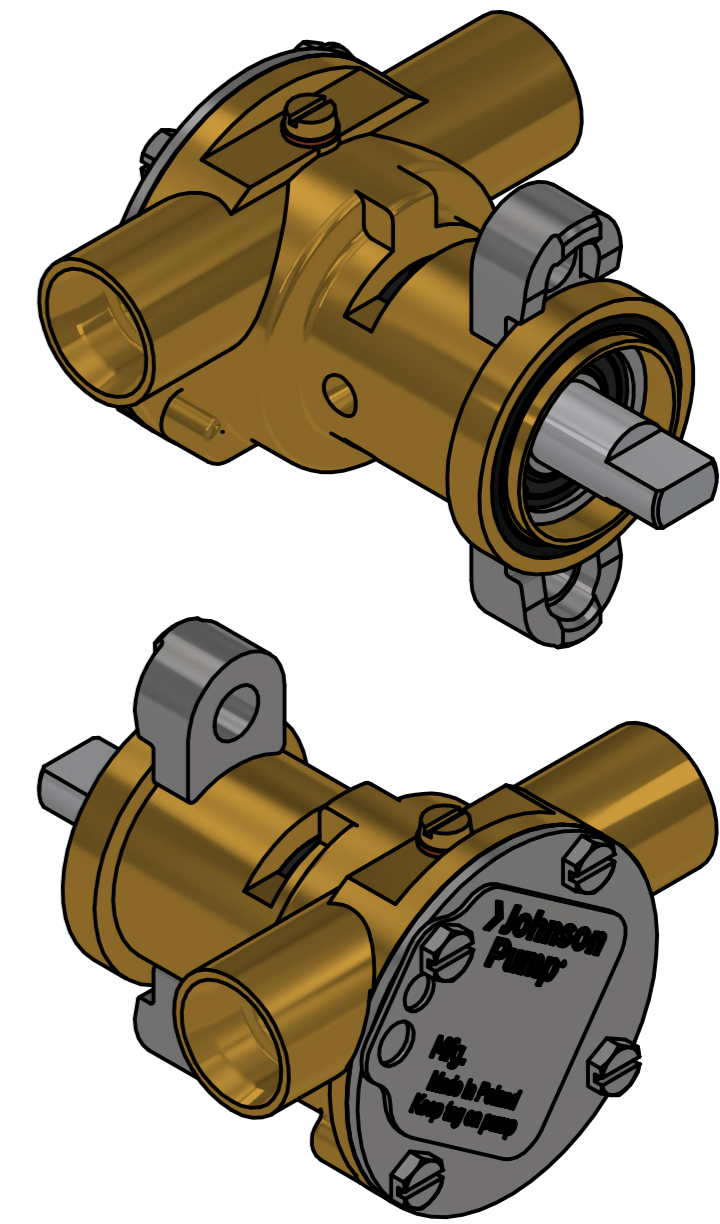
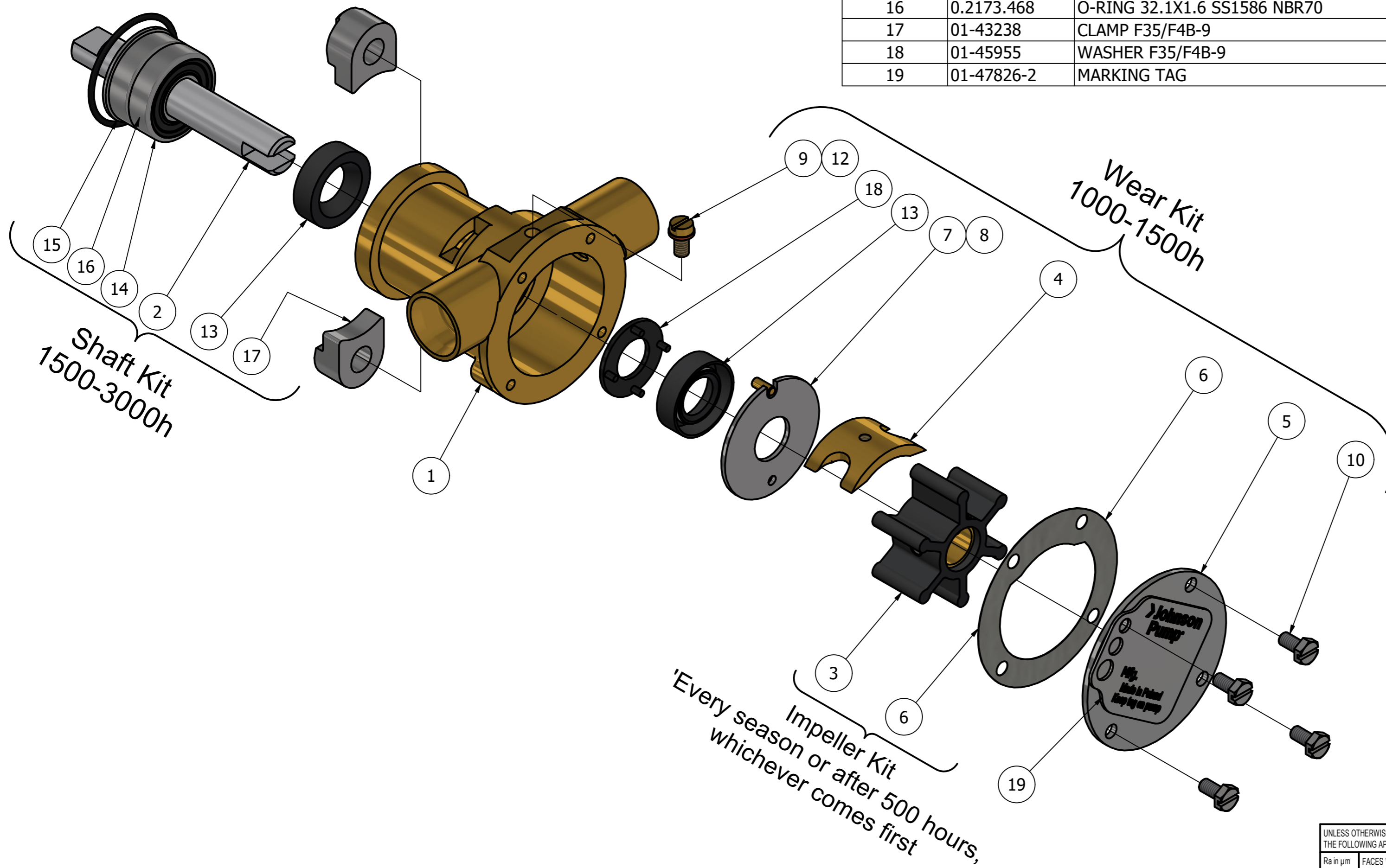

ISO VIEW

This Drawing/Document and information shown contains proprietary information of SPX FLOW and must not without permission and written consent be reproduced, copied, transmitted, transferred, disclosed, undue use, shown or handed out to any unauthorized person and is to be maintained in confidence.

REVISION HISTORY				
ECN	REV	ECN DESCRIPTION	DATE	SIGN
	P01		26.11.2024	

UNLESS OTHERWISE STATED THE FOLLOWING APPLIES:		NAME	DATE	The component or product design and specified according to this drawing must comply with applicable EHS laws and EU-directives	
Ra in µm	FACES WITHOUT TOLERANCES ACC. TO	DRAWN	25-Feb-2025	MASTER	STATUS
ISO 1302	ISO 2768 - mK	APPROVED			WorkInProgress
		MATERIAL	WEIGHT	0.5 kg	TYPE
					F35B-9
					SCALE
					1:1
DIN ISO 13715		PROJECT NUMBER	2652	DESCRIPTION	
Outside edge	Inside edge	EXPLODED VIEW OF F35B-9 IMPELLER PUMP			
0.25	0.5	SPXFLOW		DRAWING NUMBER	
		Johnson Pump		10-35211-5	
					REVISION
					P01