

CUSTOMER DETAILS

OEM PUMP PART NO	STM8921
MANUFACTURER	VETUS
ENGINE	DT64, DTA64, DT67 & DTA67
PUMP DESCRIPTION	F7B-9 IMPELLER PUMP 1/1 CAM

PART LIST

DRAWING POSITION	COMPONENTS	COMPONENT DESCRIPTION	QTY	IMPELLER KIT	WEAR KIT	SHAFT KIT	SCREW KIT
1	01-13582	PUMP BODY F7B-9	1				
2	01-35964	SHAFT F7B-9	1			X	
3	01-47769-2	END COVER F7B	1		X		
4	08-1028BT-1	IMPELLER F7 MC 97 THREAD	1	09-1028BT-1			
5	01-46899	CAM 1/1 F7B	1		X		
6	01-42400	PIN F35B-/F7B/F70B	1		X		
7	01-46798-2	WEAR PLATE F7B	1		X		
8	01-45680	WASHER F5B/F6B/F7B	1		X		
9	0.2233.403	LIP SEAL 17X40X7 NBR	1			X	
10	01-46924	SPACER F7B-9	1			X	
11	0.0279.301	SCREW M5X8 ISO1207 A4	6		X		
12	0.0279.033	SCREW M5X8 ISO1207 BRASS	1		X		
13	0.2172.012	O-RING 63.22X1.78 NBR70	1	09-1028BT-1	X		
14	0.2230.015	V-RING 15.5-17.5 NBR/65SH	1			X	
15	0.3431.742	BALL BEARING 6203-2RSH	2			X	
16	0.2247.022	MECH. SEAL COMPL D16	1		X		
17	0.0371.040	RETAIN. RING BORE D40 DIN472 SPRST	1			X	
18	0.0370.017	RETAIN. RING SHAFT D17 DIN471 SPRST	1			X	
19	0.0370.516	EXT. CIRCLIP D16 DIN471 PHB	1		X		
20	0.2173.886	O-RING D82X4 (NBR 70)	1			X	
21	0.0503.011	WOODRUFF KEY 3x5 DIN6888 ST	1			X	
22	0.0185.076	NYLOC NUT M12	1			X	
24	01-47201	CLAMP F7 (VETUS)	2			X	
25	01-47826-2	MARKING TAG	1				

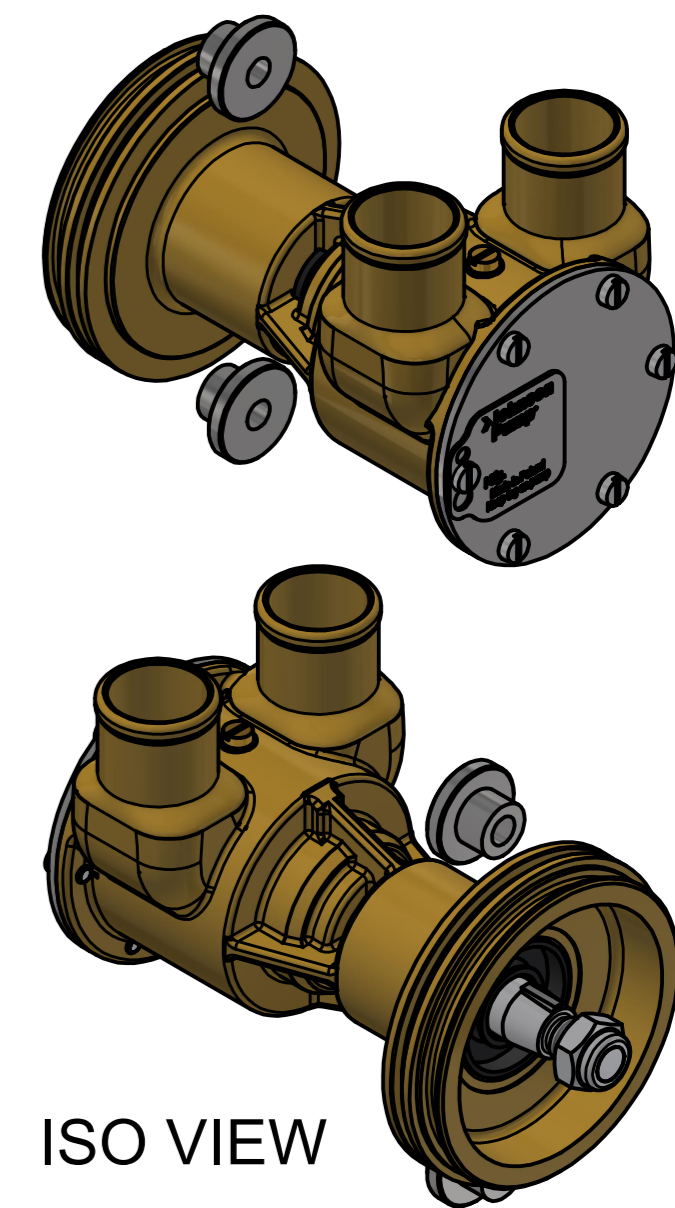
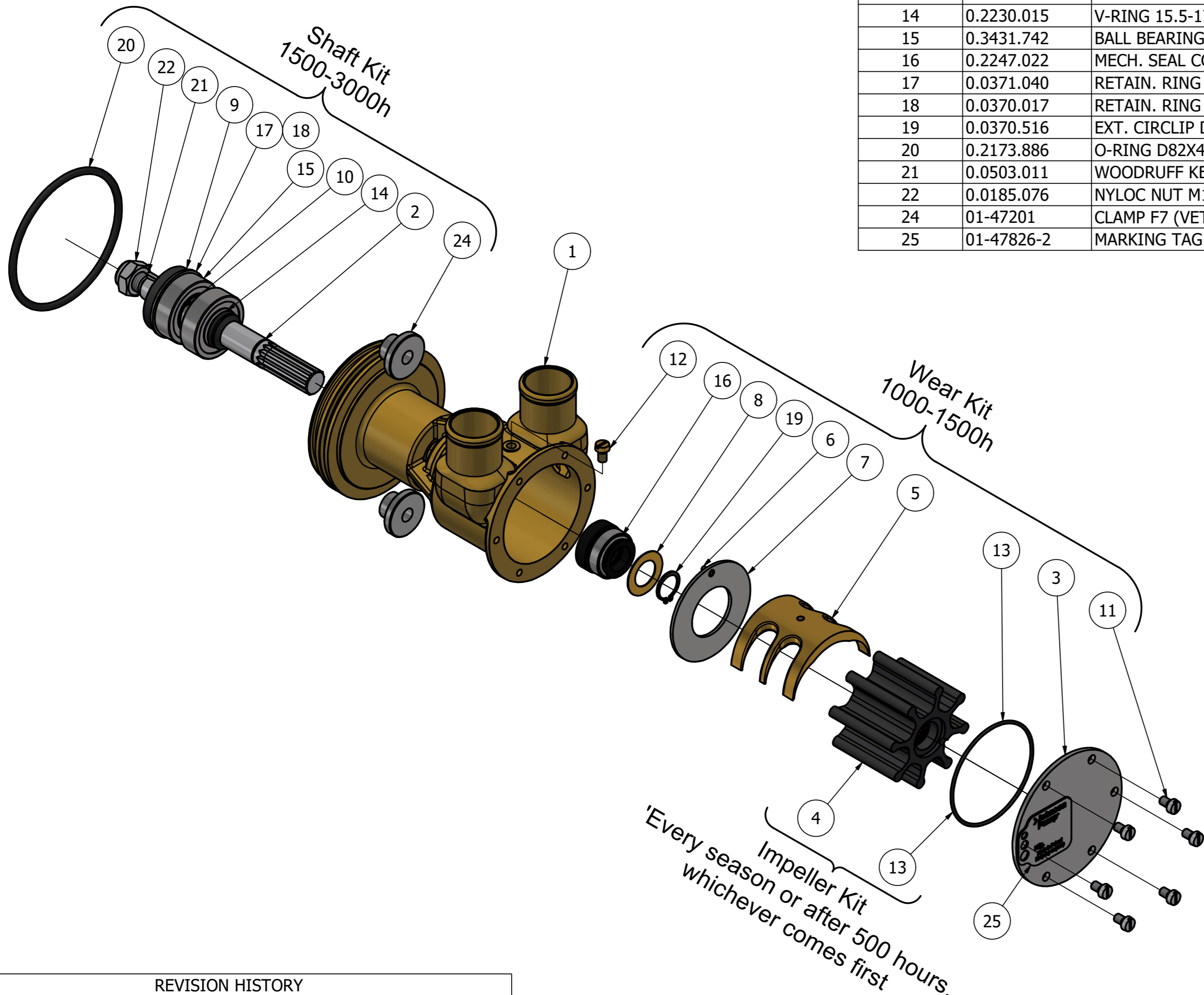

REVISION HISTORY				
ECN	REV	ECN DESCRIPTION	DATE	SIGN
	P01		15-Nov-2024	

UNLESS OTHERWISE STATED THE FOLLOWING APPLIES:		NAME	DATE	The component or product design and specified according to this drawing must comply with applicable EHS laws and EU-directives	
Ra in µm ISO 1302	FACES WITHOUT TOLERANCES ACC. TO ISO 2768 - mK	M.G	15-Nov-2024	MASTER	STATUS WorkInProgress
DIN ISO 13715 Outside edge Ra 0.25 Inside edge Ra 0.5		PROJECT NUMBER	2652	WEIGHT	2.5 kg
SPXFLOW Johnson Pump		TYPE	F7B-9	SCALE	1:2
DESCRIPTION				EXPLODED VIEW OF F7B-9 IMPELLER PUMP 1/1 CAM	
DRAWING NUMBER				10-24630-03	
REVISION				P01	

This Drawing/Document and information shown contains proprietary information of SPX FLOW and must not without permission and written consent be reproduced, copied, transmitted, transferred, disclosed, undue use, shown or handed out to any unauthorized person and is to be maintained in confidence.