

CUSTOMER DETAILS

OEM PUMP PART NO	1785016
MANUFACTURER	SCANIA
ENGINE	DI13
PUMP DESCRIPTION	F9B-9 IMPELLER PUMP OEM

PART LIST

DRAWING POSITION	COMPONENTS	COMPONENT DESCRIPTION	QTY	IMPELLER KIT	WEAR KIT	SHAFT KIT	SCREW KIT
1	01-13079-11	PUMP BODY F9B-9	1				
2	01-35282	SHAFT F9B-9	1			09-47556-106	
3	01-45173	CAM 1/1 F9B-9	1		09-47555-106		
4	08-814B	IMPELLER F9 NEOPRENE	1	09-814B			
5	01-47771-2	END COVER F8/F9/F95 SS	1		09-47555-106		
6	0.2172.142	O-RING 90.00X2.5 NBR70	1	09-814B	09-47555-106		
7	01-46538	WEAR PLATE F8/F9/F95 SS	1		09-47555-106		
8	01-42426-2	PIN SS	1		09-47555-106		
9	01-42427-15	SLINGER F8/F9B-	1		09-47555-106	09-47556-106	
10	0.0138.134	TAP BOLT M6X12 DIN933 A2	5				09-47553-107
11	0.0252.189	ALLEN SCREW M8X25 A4	1		09-47555-106		
12	01-46790-02	WASHER D8.2XD14X1 CU	1		09-47555-106		
13	0.0370.525	EXT. CIRCLIP D25 DIN471 BRONZE	1		09-47555-106		
14	0.0371.072	RETAIN. RING BORE D72 DIN472 SPRST	1			09-47556-106	
15	0.0370.030	RETAIN. RING SHAFT D30 DIN471 SPRST	2			09-47556-106	
16	0.2247.008	MECH. SEAL COMPL FA25.47.14	1		09-47555-106		
17	0.2234.006	LIP SEAL 30X62X7 DIN3760	1			09-47556-106	
18	0.3431.684	ANGULAR CONTACT BEARING 3306ATN9	1			09-47556-106	
19	01-47826-2	MARKING TAG	1				

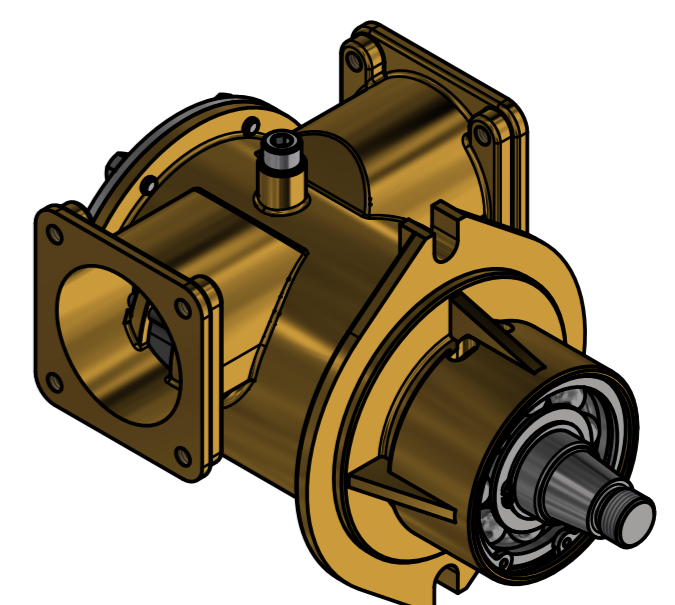
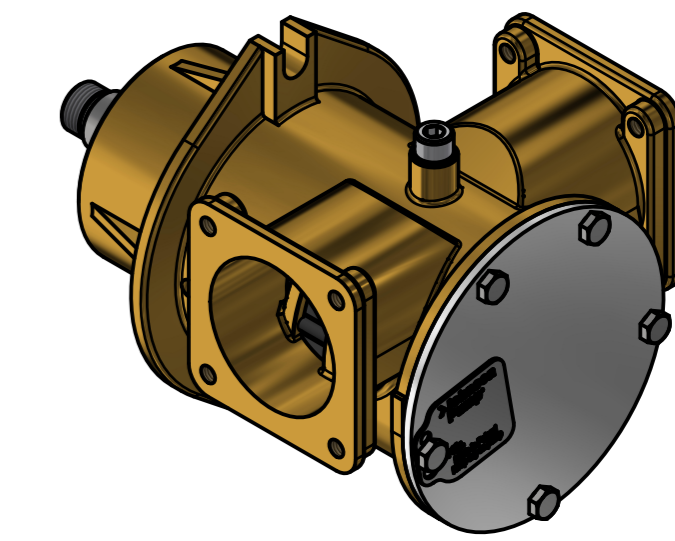
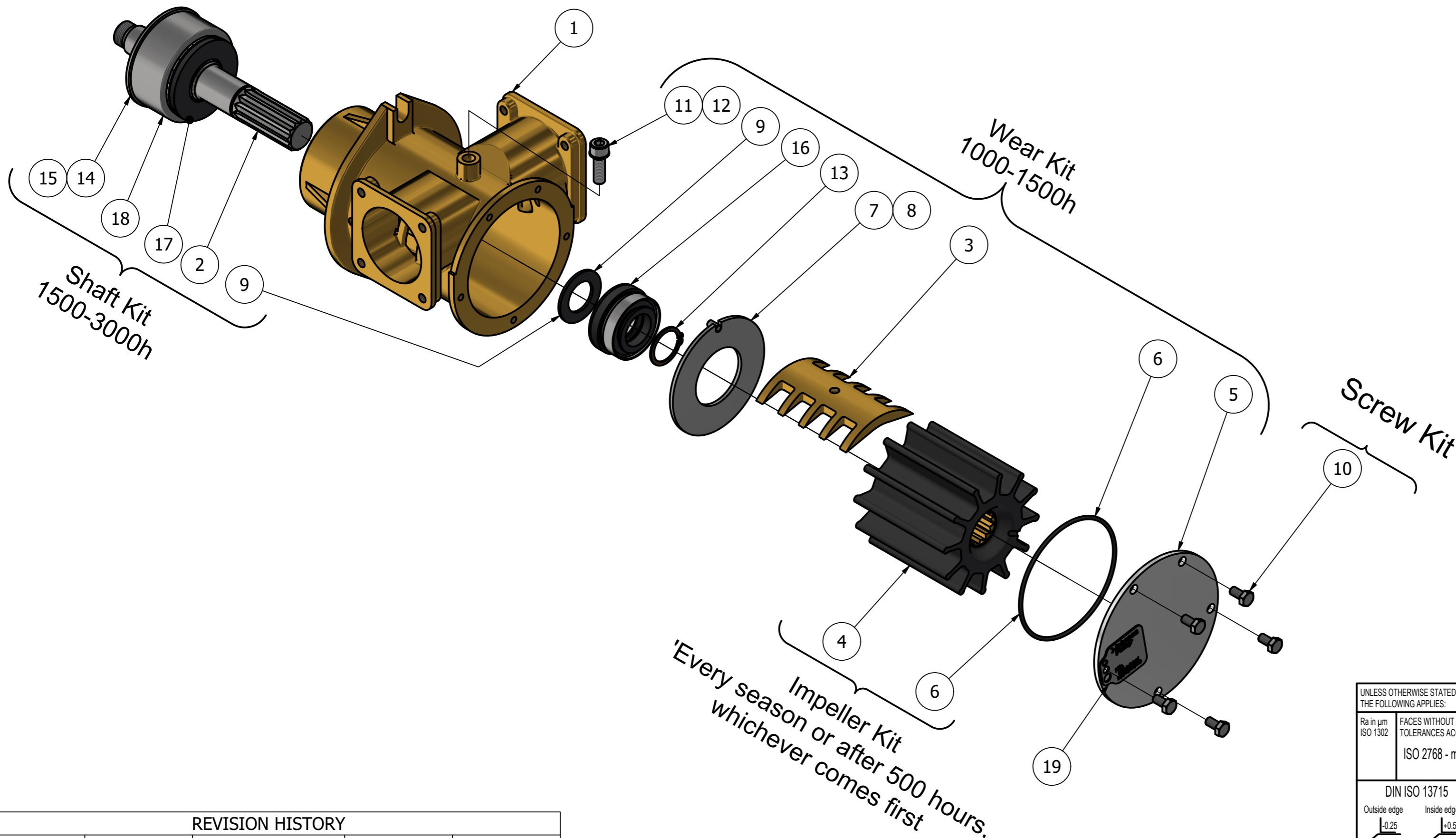

ISO VIEW

REVISION HISTORY				
ECN	REV	ECN DESCRIPTION	DATE	SIGN
	P01		12-Nov-2024	M.G

UNLESS OTHERWISE STATED THE FOLLOWING APPLIES:		NAME	DATE	The component or product design and specified according to this drawing must comply with applicable EHS laws and EU-directives	
Ra in µm	FACES WITHOUT TOLERANCES ACC. TO ISO 2768 - mK	M.G	2024-11-12	MASTER	STATUS WorkInProgress
APPROVED	M.G				PROJECTION METHOD ISO 128
MATERIAL		WEIGHT	5,9 kg	TYPE	F9B-9
		SCALE	1:2.5		
DIN ISO 13715		PROJECT NUMBER	2652	DESCRIPTION	
Outside edge	Inside edge			EXPLODED VIEW OF F9B-9 IMPELLER PUMP	
±0.25	±0.5			DRAWING NUMBER	
				10-24308-11	
				REVISION	
				P01	

This Drawing/Document and information shown contains proprietary information of SPX FLOW and must not without permission and written consent be reproduced, copied, transmitted, transferred, disclosed, undue use, shown or handed out to any unauthorized person and is to be maintained in confidence.