

Instruction Manual
Viking Power 16

12/24 V DC

Viking Power 16 mounted to DC motor 12/24 V

Please follow all instructions before attempting an installation.

Typical applications

The Viking Power 16 is a single diaphragm DC-pump. This pump is the ideal choice for shower drain, waste water and bilge pumping. Its compact design and flexible orientation give a very adaptable mounting and installation in the boat.

Model number

Viking Power 16 12V 10-13350-03
 Viking Power 16 24V 10-13350-04

Features

- 16 L/min (4.2 GPM) at open flow
- 15 L/min (4.0 GPM) at 0.1 bar pressure
- Compact and flexible configuration and installation
- Quick disconnect fittings (1" or ¾" hose and ½" BSP) straight included and 90° as accessory
- Quiet operation
- Smooth flowing
- Self priming to 3 m (10 feet)
- Pump head can be rotated 360°
- Three alternatives to motor orientation
- Dry running without damage
- No filter required
- Ball-bearing supported transmission
- Low power consumption (30W)
- Meets ISO15083 Small Craft Bilge Pump standard for boats up to 12 m/40 feet

Working principle

Single-chamber, self-priming diaphragm pump. To obtain good self-priming ability and a filter-less solution, the pump is designed with a large single diaphragm and a long stroke. This way a lot of water is pushed through the valves in each stroke and any debris is flushed through.

Technical description

Body: Nylon

Valves: Nitrile

Diaphragm: Reinforced nitrile

Connection: KlickTite™ XL connectors

1" hose or ¾" hose and
 ½" BSP, straight included
 and 90° as accessory

Fasteners: Stainless steel

Foot: Painted zink plated steel

Max. head: 3 meters (10 feet)

Max.

suction lift: 3 meters (10 feet)

Max head

& lift: 4 meters (13 feet)

Motor: 30 W at 1 m head
 12/24 V DC (with built-in
 thermal protection)

Fuse size: 8 A – 12V / 4 A – 24V

The pump is CE marked according to the following standards:

- EN55014-1:2000/Radio disturbance
- EN55014-2:1997/Radio disturbance
- ISO8846: Small Craft – Electrical devices – Protection against ignition of surrounding flammable gases
- ISO8849:2003/ Small craft – Electrically operated bilge pumps
- ISO10133: 2001/Small Craft – Electrical systems – Extra-low voltage DC installations

Drawing

See page 25

Pressure and Capacity data

Pressure Bar	kPa	Psi	Flow		Amp. draw	
			L/min	USGPM	12V	24V
0	0	0	16.2	4.2	2.0	1.0
0.1	10	1.5	15.1	4.0	2.3	1.2
0.2	20	2.9	13.7	3.6	2.8	1.4
0.3	30	4.4	12.5	3.3	3.4	1.7
0.4	40	5.8	11.3	3.0	4.0	1.9
Fuse required					8 A	4 A

Installation and maintenance

Installation

Locate the pump in a dry location.

- If the pump is mounted vertically, the motor must be above the pump house
- Mark screw positions and drill pilot holes.
- Mount the pump using stainless steel screws with the enclosed stainless steel washer. Make sure that the plastic spacers are in their correct position. Take care not to over compress the vibration dampening rubber feet. (The screws are too tight if the pump house is in contact with the surface.)
- Reinforced flexible tubing is recommended.
- Use stainless steel hose clamps to secure tubing to quick disconnect fittings and other hose barbs in the system.

Pump configuration

The pump can be configured in three different ways:

- With the motor to the left
- With the motor to the right
- With the motor straight up

The set-up can easily be changed by following this procedure:

1. Unscrew the six screws holding the pump to the steel foot
2. Set the pump with the motor facing in the desired direction
3. Fasten the six screws

Electrical installation

The pump must be installed according to ISO 10133 (Small craft – Electrical system – Extra low voltage DC installation for continuous current). **Note: The fuse must be ignition protected.**

The motor is equipped with built in thermal protection to prevent the motor from overheating. The protection is automatically restored when the motor is cooled.

If the pump is connected with separate earth lead, this should be yellow/green and connected to the motor base. See the wiring table (next page) for correct installation. Negative wire must be black. Choose wire size in accordance with total wire length (see table next page). The wire connections must be sealed with a marine sealant.

Note: Before installation with electrical control systems, check that equipment to be used is of sufficient rated capacity to accept amperage draw of motor. Low voltage will cause motor to overheat.

Maintenance

The pumps valves inside the pump house should be regularly cleared from debris to prevent reduced performance.

This is done by unscrewing the house clamp and opening the house. Make sure pump is disconnected from the power supply.

Wiring diagram

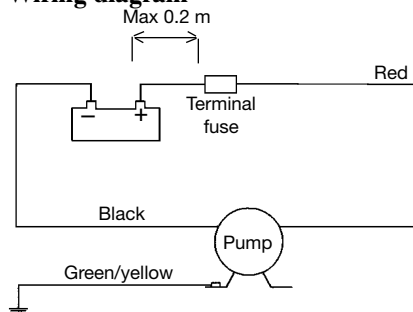

Other electrical devices, eg switch, circuit breaker, must be installed between the pump and the positive (+) lead on the battery (on the red wire).

Wiring dimensions

(Based on 10% voltage drop)

Wire size	Max wire length* in m		
		12V	24V
1.0 mm ² #18 AWG		13	56
1.5 mm ² #16 AWG		20	84
2.5 mm ² #14 AWG		34	140

* The wire length is the total distance from the battery to the pump and back to the battery. It is recommended to use a relay with a light wire from the main cable to shorten the main leaders.

Self-priming

Pump is self-priming up to 3 m/10 feet.

Dry running

The pump can be run dry without any harm. It will however unnecessary reduce your battery power.

Winterizing

Drain the pump from water by pumping it until it primes air and there is no fluid coming from the outlet.

Service instructions

Change of diaphragm

1. Remove the two screws that hold the clamps, and remove the two clamps
2. Remove the pump housing
3. Remove the screw that hold the diaphragm and the diaphragm washer
4. Remove the diaphragm and the diaphragm washer
5. Mount the new diaphragm and the new diaphragm washer with the new screw
6. Assemble the pump housing and the clamps

Change of pump housing

1. Remove the two screws that hold the clamps, and remove the two clamps
2. Remove the pump housing
3. Assemble the new complete pump housing and the clamps

Cleansing check valves

1. Remove the two screws that hold the clamps, and remove the clamps
2. Remove the pump housing
3. Inspect the rubber check valves and remove any debris
4. Assemble the pump housing and the clamps

Trouble shooting chart

Symptom

1. Pump does not run.

Cause

- 1.1 Tripped thermal protector or blown fuse.
- 1.2 Faulty wire connection or blown fuse.
- 1.4 Motor malfunctioning.
- 1.5 Pump/motor frozen.

Solution

- 1.1.1 Check fuse. If motor is overheated let it cool down prior to restart.
- 1.2.1 Check battery/power supply, main switch and wiring._
- 1.4.1 Change pump._
- 1.5.1 Thaw pump and system and check for damage. The pump/ motor is liable to damage when a frozen pump is started

2. Pump does not prime.

- 2.1 Tank empty.
- 2.2 Debris in check-valves.
- 2.3 Perforated diaphragm.
- 2.4 Leak on inlet side of pump.
- 2.5 Inlet or outlet plumbing restricted. Restriction on outlet side of pump/too high pressure.

- 2.1.1 Fill up tank.
- 2.2.1 Open the pump body by unscrewing the two supporting screws and clean the check-valves.
- 2.3.1 Replace diaphragm.
- 2.4.1 Check tightness of hose connections at pump and tank.
- 2.5.1 Check plumbing and valves

3. Low flow/pressure.

- 3.1 Leak on inlet side of pump.
- 3.2 Leak on outlet side of pump.
- 3.3 Perforated diaphragm
- 3.4 Motor malfunction
- 3.5 Debris in check-valves

- 3.1.1 Check tightness of hose connections, check hose for possible damage
- 3.2.1 Check tightness of hose connections, check hose for possible damage.
- 3.3.1 Replace diaphragm
- 3.4.1 Change pump
- 3.5.1 Open the pump body by unscrewing the two supporting screws and clean the check-valves.

4. Pump is excessively noisy.

- 4.1 Inlet or outlet plumbing restricted. Restriction on outlet side of pump/too high pressure.
- 4.2 Pump mounting is loose.
- 4.3 Defective motor
- 4.4 Defective transmission

- 4.1.1 Check plumbing
- 4.1.2 Ensure that valves on inlet/outlet are open
- 4.2.1 Tighten screws
- 4.3.1 Change pump
- 4.4.1 Change pump

Reservdelista
Parts list
Teilliste

Liste des pièces
Lista de piezas
Elenco delle parti

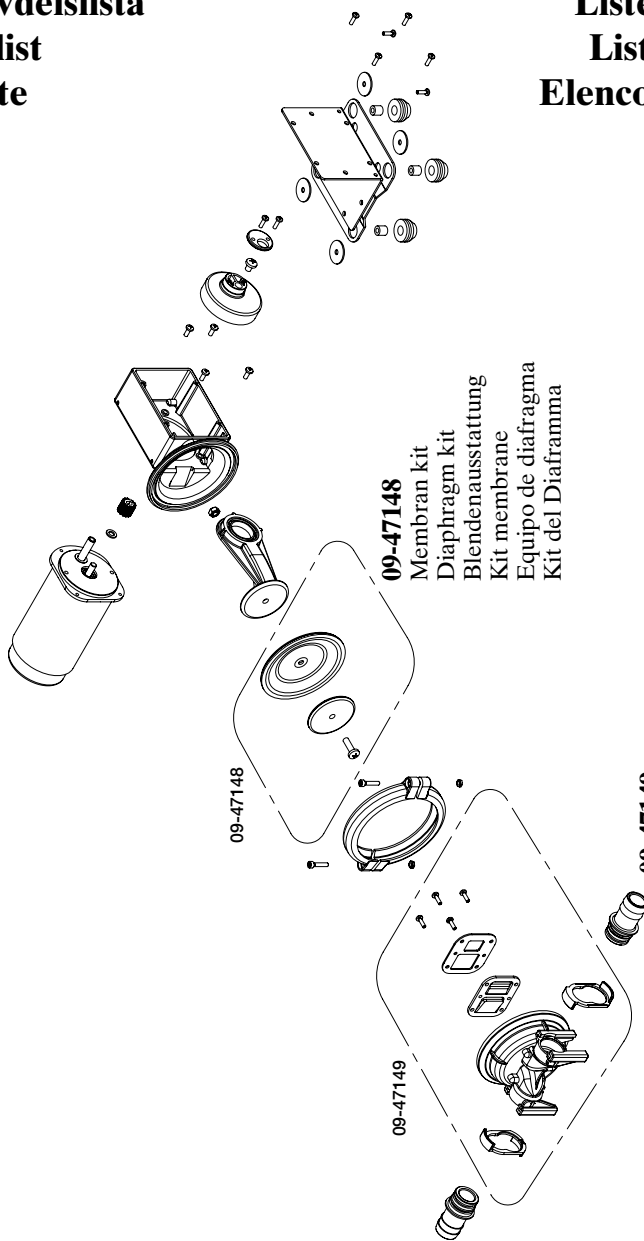

Tillbehör Accessories Zubehör

Accessoires Accesorios Accessori

Snabbanslutningar Quick disconnect fittings Schnellwechsellarmaturen

Raccords à déconnexion rapide Racores de abertura rápida Raccordi a scollimento rapido

09-47116

¾" Hose barb straight
¾"-Schlauchbefestigung, gerade
Raccord cannelé droit pour tuyau ¾" (19 mm)
¾" tubo flexible acanalado recto
Flessibili diritti con estremità a gancio da ¾"

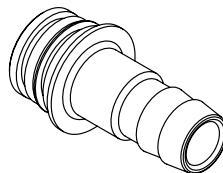

09-47117

1" Hose barb straight
1"-Schlauchbefestigung, gerade
Raccord cannelé droit pour tuyau 1" (25 mm)
1" tubo flexible acanalado recto
Flessibili diritti con estremità a gancio da 1"

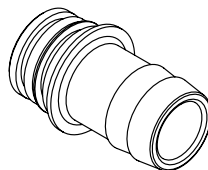

09-47118

¾" Hose barb 90°
¾"-Schlauchbefestigung, 90°
Raccord cannelé 90° pour tuyau ¾" (19 mm)
¾" tubo flexible acanalado 90°
Flessibili a 90° con estremità a gancio da ¾"

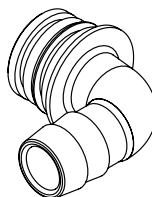

09-47119

1" Hose barb 90°
1"-Schlauchbefestigung, 90°
Raccord cannelé 90° pour tuyau 1" (25 mm)
1" tubo flexible acanalado de 90°
Flessibili a 90° con estremità a gancio da 1"

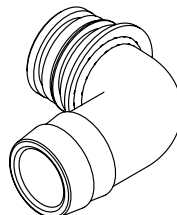

**Dimensioner
Dimensions
Abmessungen**

**Dimensions
Dimensions
Dimensioni**

