



Models 33745-0000 34060-0130
 33760-0000 34060-0130
 33799-0000

UTILITY HAND PUMPS GENERAL INFORMATION

Jabsco hand pumps. Pump more liquid with less effort! They never need coaxing or priming and give full suction on the first stroke. Pumps can be used in any position.

Uses include bilge pumping, oil draining, diesel fuel transfer, and many other liquid transfer applications. NOTE: Oil temperature should not exceed 140°F.

Long life brass cylinders, high-quality oil resistant plungers, intake and discharge caps are used. Some models include hose(s) or adjustable mounting brackets. Available in two sizes with 1-3/4" and 1-1/4" diameter cylinders.

MAINTENANCE

PUMPS USED IN DIESEL FUEL APPLICATIONS MUST BE FLUSHED CLEAN AFTER USE TO PREVENT NEOPRENE PART DISTORTION.

To disassemble pump for cleaning and repair, pull handle out approximately 4" and place screwdriver carefully under bottom of spout cap and over outside of cylinder roll. Lift up on screwdriver and pry off spout cap. Pull out plunger shaft assembly. Lift full floating plunger off seat and clean between cup and seat. Remove intake cap in same way as spout cap. Take disc valve from cylinder and clean under neoprene flapper. Run rag through cylinder for cleaning.

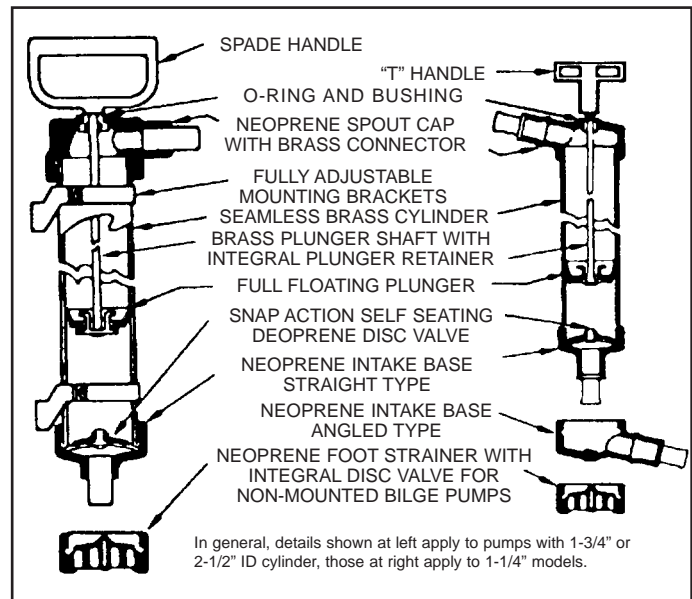

UTILITY HAND PUMPS

To reassemble pump, place disc valve in cylinder, snap intake cap back onto cylinder being sure undercut in cap is over cylinder roll. Insert plunger shaft assembly into cylinder and snap spout cap over cylinder roll.

Oil pump internally and coat exterior of brass cylinder with corrosion inhibitor or light oil for storage.

SPECIFICATIONS

MODEL	STROKES PER GAL	CYL DIA.	STROKE LENGTH	OVERALL LENGTH	HOSE CONNECTION	HOSE SUPPLIED	WT.
33745-0000	7	1-3/4"	14"	22-1/2"	1"	NONE	4.0
33760-0000	15	1-1/4"	13"	17"	1/2"	5' of 1/2"	1.5
33799-0000	26	1-1/4"	7-1/2"	12"	1/2"	3' of 1/2" 40" of 5/16" 40" of 1/4"	2.0
34060-0010	40	1-1/4"	4-5/8"	10-1/4"	1/2"	2' of 1/2" 40" of 1/4"	1.0
SPECIAL PURPOSE PUMP*							
34060-0130	Marine Engine Oil Drain Pump with 3/4" female garden hose fitting on suction connection for OMC; and MerCruiser 3/4 NH Threaded Dip-Stick Tube. Includes 2 feet of 1/2" hose.						1.0

* PERFORMANCE AND SPECIFICATIONS COMPARABLE TO MODEL 34060-0010.

† MerCruiser is a registered trademark of the Brunswick Corporation.

NOTICE: Do not push dip-stick tube too far into the engine or it may get caught and cause a problem when removing.

UTILITY HAND PUMPS

CYLINDER DIAMETER		PART DESCRIPTION	PART NO.
1-1/4*	1-3/4"		
x		Handle "T"	35416-0000
	x	Handle Spade	33785-0020
x		Bushing	33704-0000
x		O-ring	33721-0000
x		Neoprene Spout Cap with Connector	33631-0100
x		Full Floating Plunger	32450-0000
x		Straight Intake Base with Connector	33838-0100
x		Disc Valve - Straight Intake	36042-0030
x		Foot Strainer with Integral Valve	33632-0100
x		Mounting Brackets, pair	33829-0100
x	(33799-0000 Only)	Adaptor Boot with Connector	33714-0000
x		Draw Tube, 1/4" Diameter	33815-0040
x		Draw Tube Reducer 1/2 x 1/4	33857-0000
x		Conical Collar (for both Can-Top pumps)	34468-0000
x		Angled Base with Connector	33839-0100
	x	Bushing	33749-0000
	x	O-ring	33946-0000
	x	Neoprene Spout with Connector	33729-0100
	x	Full Floating Plunger	32264-0000
	x	Straight Intake Base with Connector	33741-0100
	x	Disc Valve (fits either straight or angled intake)	36029-0000
	x	Foot Strainer with Integral Valve	36032-0000
	x	Mounting Brackets, pair	33822-0100
	x	Brass Plunger Shaft and Retainer (13-1/2")	33784-0100

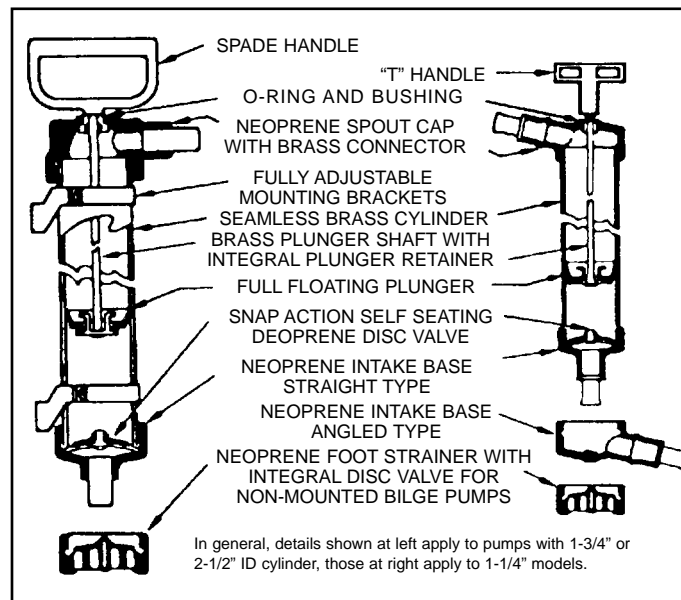

ITT Jabsco

A Unit of ITT Fluid Technology Corporation



THE PRODUCTS DESCRIBED HEREIN ARE SUBJECT TO THE JABSCO ONE YEAR LIMITED WARRANTY, WHICH IS AVAILABLE FOR YOUR INSPECTION UPON REQUEST.

U.S.A.
ITT Jabsco
1485 Dale Way, P.O. Box 2158
Costa Mesa, CA 92628-2158
Tel: (714) 545-8251
Fax: (714) 957-0609

UNITED KINGDOM
ITT Jabsco
Bingley Road, Hoddesdon
Hertfordshire EN11 0BU
Tel: +44 (0) 1992 450145
Fax: +44 (0) 1992 467132

CANADA
ITT Fluid Products
55 Royal Road
Guelph, Ontario N1H 1T1
Tel: (519) 821-1900
Fax: (519) 821-2569

JAPAN
NHK Jabsco Company Ltd.
3-21-10, Shin-Yokohama
Kohoku-Ku, Yokohama, 222
Tel: 045-4758906
Fax: 045-475-8908

GERMANY
MINTEC GmbH
Oststrasse 28
22844 Norderstedt
Tel: +49-40-53 53 73 -0
Fax: +49-40-53 53 73 -11