

(Model 8170-9001 replaces 8170 and 8170F)

DESIGN FEATURES

Body:	Bronze
Impeller:	Neoprene
Shaft:	Stainless Steel
Bearings:	Ball Bearing
Ports:	3/4" I.P.T.

SERVICE KITS

MINOR SERVICE KIT—For "onboard" repairs—includes impeller, seal and gasket.

MAJOR SERVICE KIT—For major pump overhaul—includes all parts except body.

APPLICATION: Marine engine cooling for Chrysler marine engines series M-46-4, M-47-4.

OPERATING INSTRUCTIONS

- 1. INSTALLATION**—Care should be taken that the intake and discharge piping of the engine corresponds with the port as shown on the installation drawing.
- 2. DRIVE**—Direct.
- 3. SPEEDS**—Pump is designed to operate through the entire engine range.
- 4. SELF-PRIMING**—Jabsco Pumps will operate satisfactorily at low as well as high speeds. Be sure suction lines are airtight.
- 5. RUNNING DRY**—Impeller depends on liquid pumped for lubrication. **DO NOT RUN DRY** for more than 30 seconds. Lack of liquid will burn the impeller.
- 6. PRESSURES**—Excessive back pressure due to scale and rust deposits in the water passages will reduce the flow and cause engine to overheat.
- 7. TEMPERATURES**—Impeller specially compounded to operate through the range of 45° - 180° F. For temperatures of 27° - 45° F, use -09 impeller.
- 8. FREEZING WEATHER**—Drain unit by loosening end cover plate. For closed systems, use one of the following anti-freeze compounds: Atlas "Permaguard", DuPont "Zerex", Dow Chemical "Dowguard", "Pyro", or "Telar". Do not use petroleum based anti-freeze compounds.
- 9. IMPELLER REPLACEMENT**—Remove end cover. Withdraw impeller by grasping impeller hub with pliers.
- 10. GASKET REPLACEMENT**—Always use standard pump part. A thicker gasket will reduce priming ability. A thinner gasket will cause impeller binding.
- 11. CAM REPLACEMENT**—Coat top surface of new cam and cam screw threads with permatex #1 or equivalent sealing compound before installing.
- 12. SPARE PARTS**—Avoid costly shut downs by always having a JABSCO Service Kit on hand.

JABSCO PRODUCTS 

EXPLODED VIEW

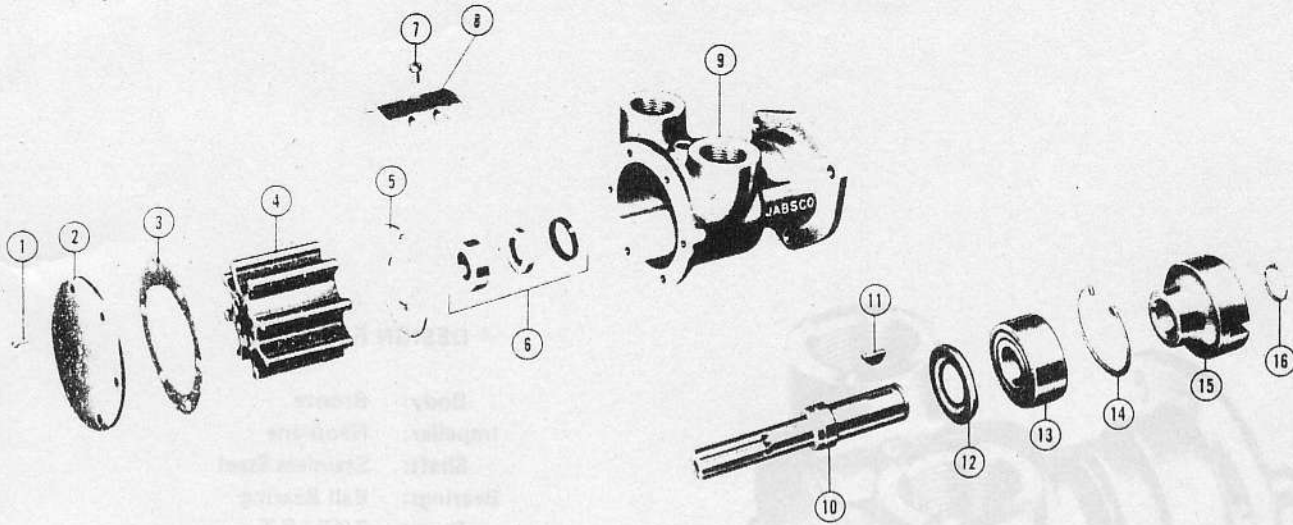

Patented and Patents Pending

PARTS LIST

KEY	PART NO.	QTY. REQ'D.	DESCRIPTION
1	91003-0010	6	End Cover Screw
2	11831-00000	1	End Cover
3	3101-0000	1	*Gasket
4	920-0001	1	*Impeller
5	4156-0000	1	Wearplate
6	96080-0080	1	*Seal
7	91004-0110	1	Cam Screw
8	3255-0000	1	Cam
9	8174-9000	1	Body
10	8177-0410	1	Shaft
11	91402-0060	1	Key
12	913-0000	1	Bearing Seal
13	92600-0060	1	Ball Bearing
14	91701-1850	1	Retaining Ring
15	8176-0000	1	Coupling
16	91700-2470	1	Retaining Ring

90118-0001 Service Kit contains parts marked with asterisk.

Model 8170 Lip Seal Version (obsolete)

- 92700-0060 - Seal
- 92000-0210 - 'O' Ring
- 3166 - Spacer
- 3298 - Slinger

Face seal cannot be installed in lip seal version.

INSTALLATION DRAWING

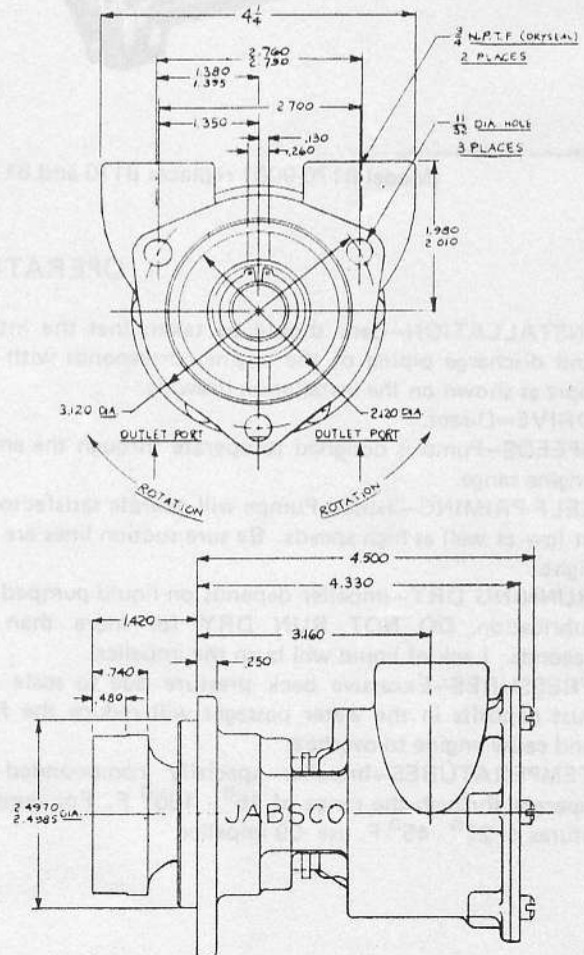

JABSCO PRODUCTS **ITT**

Marine and Recreation Components Division
International Telephone and Telegraph Corporation
1485 Dale Way, Costa Mesa, California 92626

Telephone: (714) 545-8251