

JABSCO® PUMPS

Self-Priming Pumps

205-55 4151
MODELS: 205-557
777-0001 & 777-9001

(Lip Seal)

Product Data

(Face Seal)

MECHANICAL

**BETTER
 MORE
 EXPENSIVE**

MODEL: 777-0001 & 777-9001

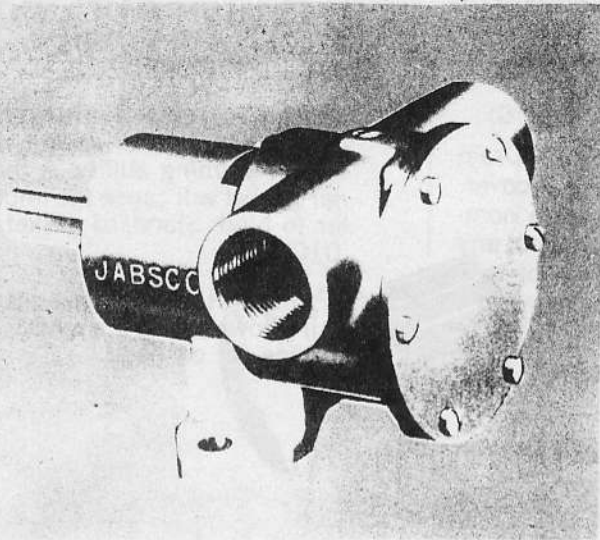

Other JABSCO models also available in bronze, plastic, cast iron and stainless steel. JABSCO Pureflo pumps are also available for sanitary applications.

DESIGN FEATURES

Body:	Bronze
Impeller:	Jabscos Neoprene Compound
Shaft:	Stainless Steel
Shaft Seal:	Mechanical Face Seal or Lip Type
Wearplate:	Replaceable
Bearings:	Shielded Ball Bearings
Ports:	1" NPT
Weight:	5 3/4 lbs. (approx.) (2,61 kg.)

VARIATIONS AVAILABLE

MODEL	VARIATION INCORPORATED
777-9051	Half Thickness Cam (Face Seal) (Where reduced capacity is required with a fixed speed. See Head Capacity Table)
777-0003	Nitrile Impeller (Lip Seal)
777-9003	Nitrile Impeller (Face Seal)

APPLICATIONS & OPERATING INSTRUCTIONS

MARINE: Pumping bilges, Wash-downs, Circulating water in bait tanks, Utility dock side pump, Engine cooling.

INDUSTRIAL: Circulating and transferring, Velocity-mixing, Pumping machine tool coolants, Return spill, Sump drainage, Chemicals, Pharmaceuticals, Soap, Liquors, Ink, Dyes, Alcohol, Various acids, Tanning liquors, Glycerine, Brine, etc.

FARMING: Pumping water for stock, Pumping water from shallow wells and cisterns, Pumping liquid ballast into tractor tires.

PLUMBING AND HOME EMERGENCY USE: Pumping out flooded basements, Cesspools, Sumps, Water heaters and water closets, Drains and sinks, Draining fishponds and pools.

1. **INSTALLATION**—Pump may be mounted in any position. Intake and discharge ports are determined by the direction of shaft rotation (refer to Dimensional drawing). Before installing, turn the pump shaft in the direction of the operating rotation.

2. **DRIVE** — Belt or Direct with flexible coupling.

Belt Drive — Overtight belt load will reduce pump bearing life.

Direct Drive — Clearance should be left between drive shaft and pump shaft when installing coupling. Always mount and align pump and drive shaft before tightening the coupling set screw.

Do not hammer pulley or drive on shaft, this may damage bearings or seal.

3. **SPEEDS** — 100 RPM to the maximum shown in the performance table. Consult the factory for operation at speeds above those shown. For longer pump life, operate at lowest possible speeds.

4. **SELF-PRIMING**—Primes at low or high speeds. For vertical dry suction lift of 10 feet, a minimum of 800 RPM is required. Pump will produce suction lift up to 22 feet when wetted. **BE SURE SUCTION LINES ARE AIR TIGHT OR PUMP WILL NOT SELF-PRIME.**

Continued

JABSCO PRODUCTS **ITT**

OPERATING INSTRUCTIONS (Cont.)

5. **RUNNING DRY**—Unit depends on liquid pumped for lubrication. **DO NOT RUN DRY** for more than 30 seconds. Lack of liquid will burn the impeller.
6. **CAUTION**—Do not pump light fraction petroleum derivatives, solvents, thinners, highly concentrated or organic acids. Consult Jabsco for proper body materials and impeller compounds. If corrosive fluids are handled, pump life will be prolonged, if flushed with water after each use or after each work day.
7. **PRESSURES**—Consult Head Capacity Table for recommended maximum for continuous operation. If pressures exceed those shown, consult the factory.
8. **TEMPERATURES**—Neoprene 45°-180°F (7°-82°C)
Nitrile 50°-180°F (10°-82°C).
9. **FREEZING WEATHER**—Drain unit by loosening end cover. The following anti-freeze compounds can be used without any adverse effects to the neoprene impeller: Atlas "Permaguard", DuPont "Zerex" and "Telar", Dow Chemical "Dowguard" and Olin Mathison "Pyro" Permanent". Most Methyl alcohol (methanol) based anti-freeze can be used. **DO NOT USE PETROLEUM BASED ANTI-FREEZE COMPOUNDS OR RUST INHIBITORS.**
10. **GASKET**—Use a standard pump part. Thicker gasket will reduce priming ability. A thinner gasket will cause the impeller to bind. Standard gasket is .010" thick.
11. **SPARE PARTS**—To avoid costly shut downs, keep a JABSCO Service Kit on hand.

PERFORMANCE TABLES

Model 777-9001

TOTAL HEAD		500 RPM		1160 RPM		1750 RPM		2100 RPM		2750 RPM		3000 RPM	
PSI (kgs/cm)	Feet of Water (Meters)	GPM (Liters/Min)	HP	GPM (Liters/Min)	HP	GPM (Liters/Min)	HP	GPM (Liters/Min)	HP	GPM (Liters/Min)	HP	GPM (Liters/Min)	HP
4.3 (0,3)	10 (3,0)	6.8 (25,7)	1/4	16.5 (62,5)	1/3	26.0 (98,4)	3/4	30.5 (115,4)	3/4	34.0 (128,7)	1 1/2	33.5 (126,8)	1 1/2
8.7 (0,6)	20 (6,1)	6.3 (23,8)	1/4	15.9 (60,2)	1/2	24.5 (92,7)	3/4	29.8 (112,8)	1	33.8 (127,9)	1 1/2	33.3 (126,0)	1 1/2
17.3 (1,2)	40 (12,2)	4.7 (17,8)	1/4	13.5 (51,1)	1/2	21.0 (79,5)	3/4	26.7 (101,1)	1	31.5 (119,2)	1 1/2	32.3 (122,3)	1 1/2
26.0 (1,8)	60 (18,3)	—	—	9.5 (40,0)	3/4	16.5 (62,5)	1	21.4 (81,0)	1 1/2	27.7 (104,8)	2	30.0 (113,6)	2
34.6 (2,4)	80 (24,4)	—	—	—	—	11.5 (43,5)	1	15.0 (56,8)	1 1/2	22.0 (83,3)	2	25.0 (94,6)	2

Model 777-9051

TOTAL HEAD		500 RPM		1160 RPM		1750 RPM		2100 RPM		2750 RPM		3000 RPM	
PSI (kgs/cm)	Feet of Water (Meters)	GPM (Liters/Min)	HP	GPM (Liters/Min)	HP	GPM (Liters/Min)	HP	GPM (Liters/Min)	HP	GPM (Liters/Min)	HP	GPM (Liters/Min)	HP
4.3 (0,3)	10 (3,0)	4.0 (15,1)	1/4	8.7 (32,9)	1/4	13.6 (51,5)	1/2	16.7 (63,2)	3/4	22.3 (84,4)	1	24.0 (90,8)	1
8.7 (0,6)	20 (6,1)	3.4 (12,9)	1/4	8.0 (30,3)	1/3	12.8 (48,4)	1/2	15.8 (59,8)	3/4	21.2 (79,9)	1	23.2 (87,8)	1 1/2
17.3 (1,2)	40 (12,2)	2.0 (7,6)	1/4	5.8 (22,0)	1/3	10.4 (39,4)	3/4	13.5 (51,1)	3/4	18.5 (70,0)	1	22.0 (83,3)	1 1/2
26.0 (1,8)	60 (18,3)	—	—	—	—	7.0 (26,5)	3/4	10.0 (37,9)	1	14.5 (54,9)	1 1/2	16.0 (60,6)	1 1/2

NOTE: Progressively longer life may be expected as operating pressures and speeds are reduced. Factory Application Engineering assistance suggested for operation in shaded areas. Capacitor start motor recommended. Tables show approximate performance for new pump with neoprene impeller.

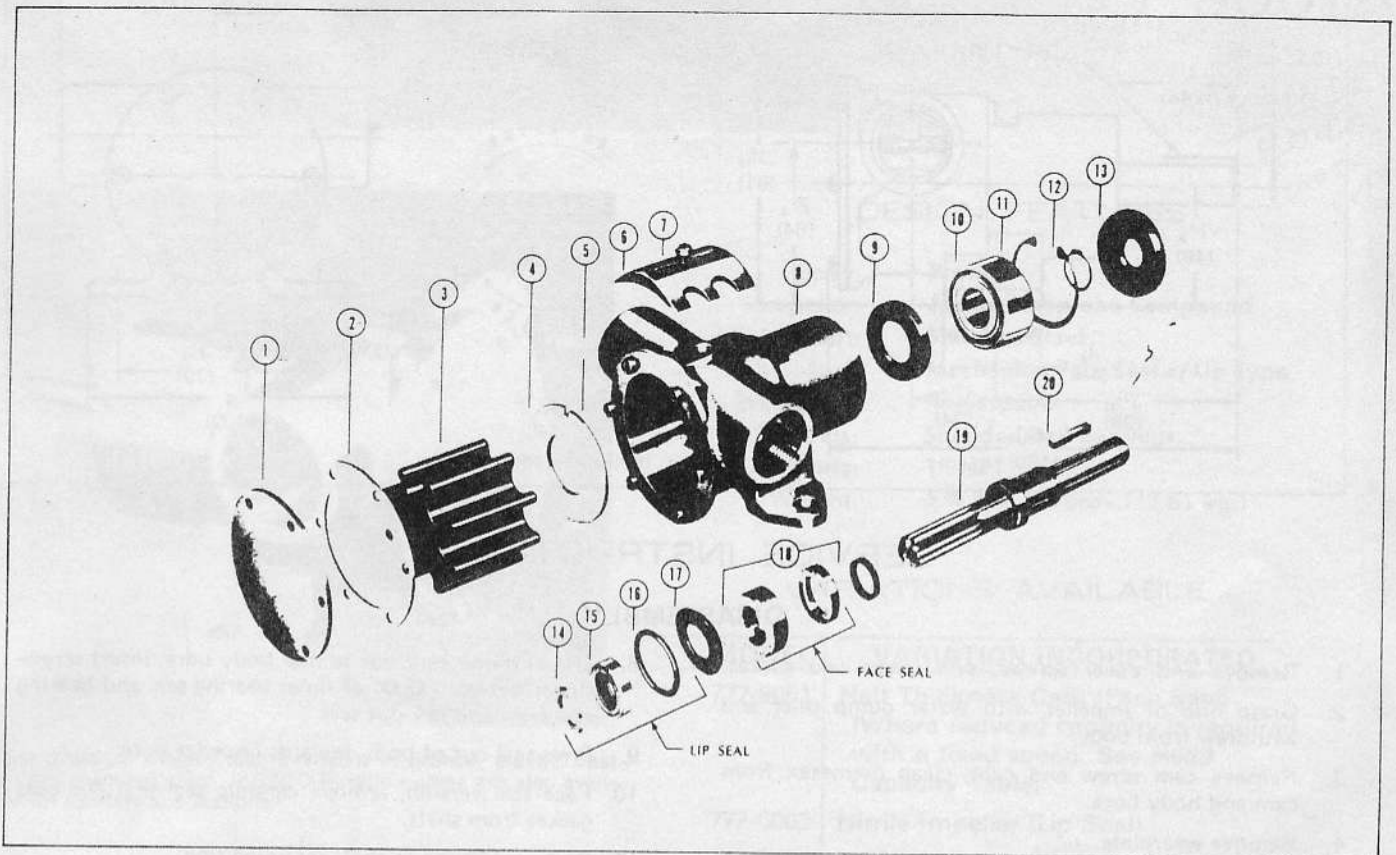

PARTS LIST

Key	Description	Model 777-0001	Model 777-0003	Model 777-9001 777-9004	Model 777-9003 777-9005	Model 777-9051
1	End Cover	11831-0000	11831-0000	11831-0000	11831-0000	11831-0000
2	*Gasket	890-0000	890-0000	890-0000	890-0000	2432-0000
3	*Impeller - Neoprene Brass Insert Nitrile Brass Insert	920-0001	— 920-0003	920-0001	— 920-0003	— 920-0001
4	Wearplate	4156-0000	4156-0000	4156-0000	4156-0000	4156-0000
5	Screw (End Cover)	91003-0010	91003-0010	91003-0010	91003-0010	91003-0010
6	Cam	934-0000	934-0000	934-0000	934-0000	2431-0000
7	Screw (Cam)	91004-0090	91004-0090	91004-0090	91004-0090	91004-0100
8	Body	798-0020	798-0020	798-0020	798-0020	798-0020
9	Bearing Seal (Inner)	913-0000	913-0000	913-0000	913-0000	913-0000
10	Ball Bearing	92600-0060	92600-0060	92600-0060	92600-0060	92600-0060
11	Retaining Ring (Brg. to Body)	91701-1850	91701-1850	91701-1850	91701-1850	91701-1850
12	Retaining Ring (Brg. to Shaft)	91700-2470	91700-2470	91700-2470	91700-2470	91700-2470
13	Bearing Seal (Outer)	914-0000	914-0000	914-0000	914-0000	914-0000
14	†Seal Spacer	3166-0000	3166-0000	—	—	—
15	*Seal (Lip)	92700-0060	92700-0060	—	—	—
16	*†O' Ring	92000-0210	92000-0210	—	—	—
17	Slinger	3180-0000	3180-0000	—	—	—
18	Seal (Face)	—	—	96080-0080	96080-0080	96080-0080
19	Shaft	6718-0000	6718-0000	6718-0000	6718-0000	6718-0000
20	Key	9215-0000	9215-0000	9215-0000	9215-0000	9215-0000
	Service Kit (Not Shown)	90010-0001	90010-0003	90118-0001	90118-0003	90118-0001

*Parts supplied in Service Kit.

†Used for models prior to August 1, 1964.

NOTE: 5915-0001, Hi Pressure Neoprene Impeller available, contact factory for application recommendations.

DIMENSIONAL DRAWING

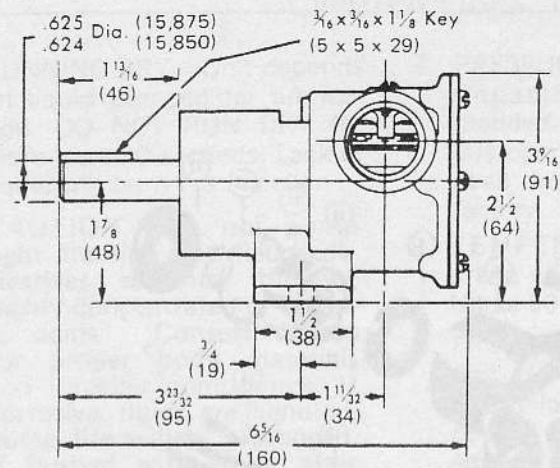

(millimeter equivalents)

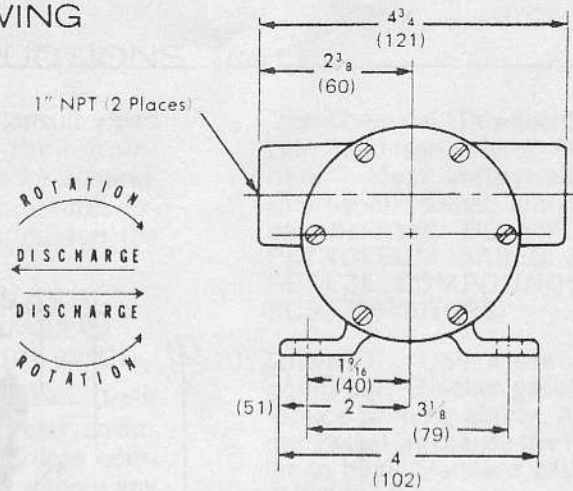

SERVICE INSTRUCTIONS

DISASSEMBLY

1. Remove end cover screws, end cover and gasket.
2. Grasp hub of impeller with water pump plier and withdraw from body.
3. Remove cam screw and cam, clean permatex from cam and body bore.
4. Remove wearplate.
5. Insert screwdriver between O.D. of outer bearing seal and bearing bore, and pry seal out.
6. Remove bearing to body retaining ring.
7. Press on impeller drive end of shaft to remove shaft and bearing assembly.
8. Use extreme care not to mar body bore, insert screwdriver between O.D. of inner bearing seal and bearing seal bore and pry out seal.
9. Press seal out of body towards impeller bore.
10. Face seal version, remove ceramic seal seat and seat gasket from shaft.
11. Remove bearing to shaft retaining ring.
12. Support bearing inner race, press on drive end of shaft to remove shaft from bearing. Do not attempt to remove bronze bushing which is pinned to shaft.
13. Inspect all parts for wear or damage and replace where necessary.

ASSEMBLY

1. Lubricate inner bearing seal lip with grease and press into body bearing seal bore with lip facing away from bearing bore.
2. Press shaft into bearing, using care to support inner race of bearing.
3. Install bearing to shaft retaining ring with flat side toward bearing.
4. Position slinger in body drain area. Insert splined end of shaft through bearing bore and guide slinger over shaft until bearing contacts body. Lip seal versions only.
5. Pressing on bearing outer race, install bearing into bore.
6. Install bearing to body retaining ring in body groove with flat side toward bearing.
7. Lubricate outer bearing seal lip with grease and press into bearing bore until it is flush with the body.
8. **Lip seal versions.** Lubricate O.D. and lip of seal, then push into place, using care not to damage or cut seal lip. (Lip faces impeller bore.)
9. **Face seal versions.** Lubricate rubber grommet in ceramic seal seat with water and install on shaft, grommet toward bearing. Install seal (carbon toward ceramic seat) in seal bore and press flush with bottom of impeller bore.
10. Install wearplate in body bore, aligning slot in wearplate with dowel pin in body.
11. Permatex cam screw threads and top side of cam and install in body with cam screw.
12. Lubricate impeller bore and end surfaces of impeller with a light coat of Marfak 2HD and start impeller into bore with a rotary motion until splines engage, then push into bore.
13. Install gasket and end cover and secure with end cover screws.

JABSCO PRODUCTS **ITT**

A Unit of International Telephone and Telegraph Corporation, 1485 Dale Way, Costa Mesa, California 92626
Telephone: (714) 545-8251