



**Model 6850-0003**

## SELF-PRIMING GASOLINE ENGINE PUMP UNIT

### FEATURES

- Body: **Bronze Construction**  
Impeller: **Nitrile (Oil Resistant)**  
Wearplate: **Replaceable**  
Shaft Seal: **Lip Type**  
Shaft: **Stainless Steel Sleeve over Steel Motor Shaft**  
Ports: **1" NPT Internal**  
Weight: **32-1/2 lb (14,7 kg)**  
Engine: **Briggs & Stratton Gasoline, 3 HP, 4 Cycle, 3000 RPM (factory setting)**



**ENGINE CAN CAUSE SPARKS OR FLAME. EXPLOSION MAY OCCUR CAUSING INJURY OR DEATH. DO NOT USE WHERE FLAMMABLE VAPORS ARE PRESENT.**

### APPLICATIONS

**MARINE** — Bait Tank Circulation, Wash Down, Utility Dock Pump, Fire Fighting.

**INDUSTRIAL** — Municipal Trucks, Priming Centrifugals, Utility Transfer Pumps.

**CONTRACTORS** — Remove Water from Excavations, Supply Water to Mortar Boxes, Cement Mixing, Wash Down Equipment, Portable Utility Truck Pumps.

**FARMING** — Fill Water Tanks, Pump Out Silo Pits (Liquid Manure), Flush and Clean Animal Pens, Pumping Water for Stock and Poultry Houses.

**PLUMBING AND HOME EMERGENCY USE** — Pumping Out Flooded Basements, Cesspools, Sumps, Etc., Drain Water Heaters and Drain Laundry Tubs, Remove Water from Low Areas.

### OPERATING INSTRUCTIONS

- INSTALLATION** — Facing pump end cover, inlet port is on the left, discharge port is on the right.
- DRIVE** — Direct.
- SPEED** — 3,000 RPM (factory setting).

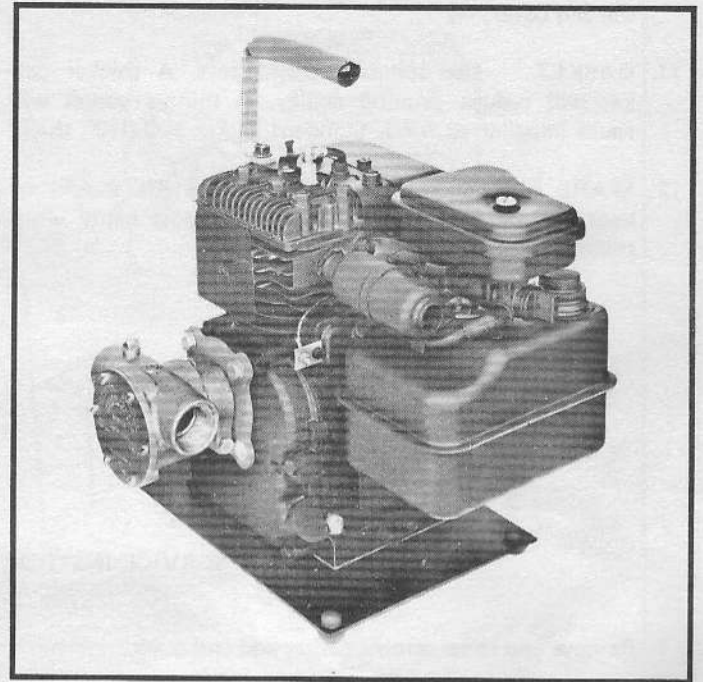

Model 6850-0003

- SELF-PRIMING** — Pump will produce a suction lift approaching 15' (4,6 m) when dry and lift up to 22' (6,7 m) when primed. **BE SURE SUCTION LINES ARE AIRTIGHT** or pump will not self-prime.
- RUNNING TIME** — Unit depends on liquid pumped for lubrication. **DO NOT RUN DRY FOR MORE THAN 30 SECONDS. LACK OF LIQUID WILL DAMAGE THE IMPELLER. DO NOT RUN PUMP FOR "TEST" UNLESS INTAKE HOSE IS IN WATER.**
- NOTICE** — If pumping light fraction petroleum derivatives, solvents, thinners, highly concentrated or organic acids, consult Jabsco Chemical Resistance Table (which is available upon request from ITT Jabsco) for proper body materials and impeller compounds. If corrosive fluids are handled, pump life will be prolonged if pump is flushed with water after each use or after each working day.
- PRESSURES** — For continuous operation, pressures should not exceed 35 PSI (2,5 kg/sq cm).
- PIPING** — For maximum efficiency and performance, use a minimum of 1-1/2" (38 mm) diameter hose or pipe in installations requiring a total of 50' to 150' (15,2 to 45,7 m) piping. For installations requiring 25' to 50' (7,6 to 15,2 m) total piping, use a minimum of 1-1/4" (32 mm) diameter hose or pipe. For installations requiring less than 25' (7,6 m) total piping, use a minimum of 1" (25 mm) diameter hose or pipe. It is recommended that 1-1/2" (38 mm) diameter hose or piping be used in all cases for pump inlet. For unusually long or complicated piping systems, contact factory for engineering assistance.

(Continued from page 1)

9. **TEMPERATURES** — Neoprene impeller is recommended for liquid temperatures of 45° to 180°F (7,2° to 82,2°C). Nitrile 50° to 180°F (10° to 82,2°C).
10. **FREEZING WEATHER** — Drain unit by loosening the end cover.
11. **GASKET** — Use standard pump part. A thicker gasket will reduce priming ability. A thinner gasket will cause impeller to bind. Standard gasket is 0.010" thick.
12. **SPARE PARTS** — A JABSCO Service Kit should be kept on hand to service all but the most badly worn pumps.

HEAD CAPACITY TABLE

TOTAL HEAD				3000 RPM	
PSI	kg/sq cm	Feet of Water	metre	GPM	L/min
4.3	(0,3)	10	(3,0)	35.5	(134,4)
8.7	(0,6)	20	(6,1)	35.0	(132,5)
17.3	(1,2)	40	(12,2)	33.4	(126,4)
26.0	(1,8)	60	(18,3)	30.0	(113,6)
35.0	(2,5)	80	(24,4)	24.5	(29,7)

NOTE: Table shows approximate head flow for new pump with neoprene impeller in US Gallons (and litres). Capacities shown are for maximum throttle setting. Reduced throttle setting will reduce capacity.

FOR EASIER START MAKE SURE IMPELLER IS WETTED.

If the pump is not used for long periods of time, starting may be made easier by removing impeller, then starting engine and allowing it to warm up for a minute. After shutting off engine, lubricate impeller with water or water pump grease and re-install in pump with a counter-clockwise rotary motion.

#### SERVICE INSTRUCTIONS DISASSEMBLY

1. Remove end cover screws, gasket and end cover.
2. Withdraw impeller.
3. Loosen cam screw and remove cam. Clean off sealant.
4. Remove wearplate.
5. Loosen nut at body clamp and remove body from engine.
6. Pressing from motor end of pump body, remove seal.
7. Remove slinger from shaft.
8. Adaptor may be removed from engine if necessary.
9. Inspect all parts for wear and replace if necessary.

#### SERVICE INSTRUCTIONS ASSEMBLY

1. Press seal into seal bore (lip facing the impeller bore).
2. Install wearplate, align slot in wearplate with dowel pin in body.
3. Apply thin coating of sealant to cam screw threads, entire top side and back end of cam and install in body with cam screw.
4. Lubricate impeller bore with a light coat of water pump grease or equivalent and install impeller. Use care not to damage seal lip with impeller sleeve.
5. Install gasket and end cover and secure with end cover screws.
6. Position slinger on shaft, aligning key in slinger with keyway of shaft. Install approximately 1/4" from motor.
7. Aligning impeller drive with shaft keyway, install pump on motor adaptor. Be sure it is seated against the shoulder.
8. Tighten body clamp nut.

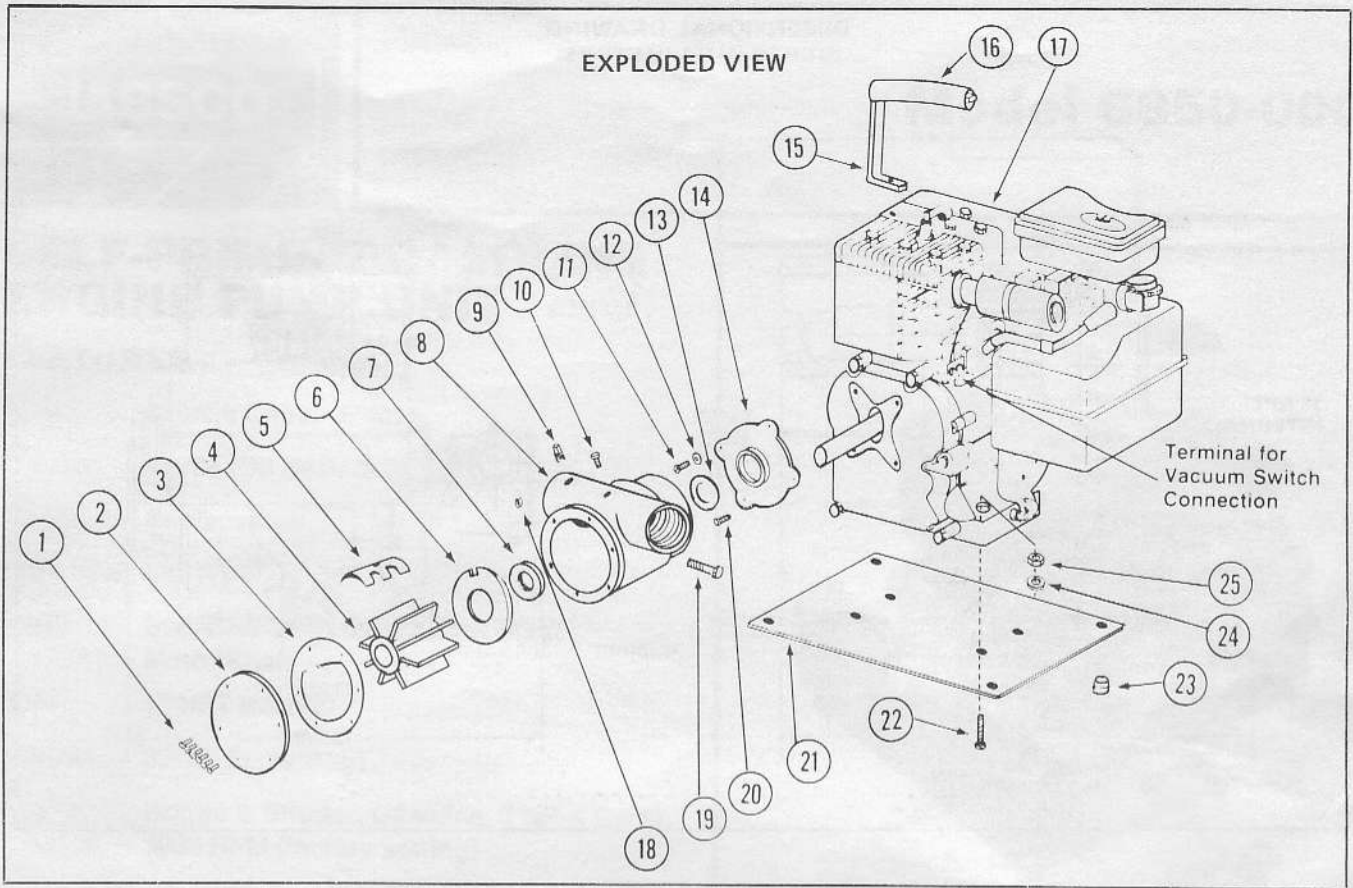

**PARTS LIST**

Key	Description	Part Number	Qty. Req.
1	Screws (End Cover)	91003-0010	6
2	End Cover	11831-0000	1
3	Gasket	3101-0000	1
4	Impeller (Neoprene) (Nitrile)	17956-0001 6056-0003	1 1
5	Cam	3255-0000	1
6	Wearplate	4156-0010	1
7	Seal (Shaft)	92700-0080	1
8	Body	6854-0000	1
9	Plug	92650-0070	1
10	Screw (Cam)	91004-0110	1
11	Bolt (Adaptor to Engine)	91094-0080	2
12	Washer (Adaptor to Engine)	91602-0130	2
13	Slinger	6398-0000	1
14	Adaptor	5243-0010	1
15	Handle	5244-0000	1
16	Handle Grip	6708-0000	1
17	Engine	97030-0050	1
18	Nut (Pump to Adaptor)	91105-0030	1
19	Bolt (Pump to Adaptor)	91095-0000	1
20	Flat Head Screw (Adaptor to Engine)	91013-0020	2
21	Base	6704-0000	1
22	Bolt (Base)	91094-0130	4
23	Rubber Bumper	92900-0020	4
24	Washer (Base)	91602-0130	4
25	Nut (Base)	91085-0130	4

**REPLACEMENT PUMP HEAD COMPLETE**

PUMP MODEL NO.	PUMP HEAD NO.	DESCRIPTION
6850-0003	6853-0003	Pump only (Less Mounting Kit and Engine) with Nitrile Impeller

**SERVICE KIT**

PUMP MODEL NUMBER	SERVICE KIT NUMBER
6850-0003	90058-0003

Kit consist of Impeller, seal and gasket.

**DIMENSIONAL DRAWING**  
INCHES (MILLIMETRES)

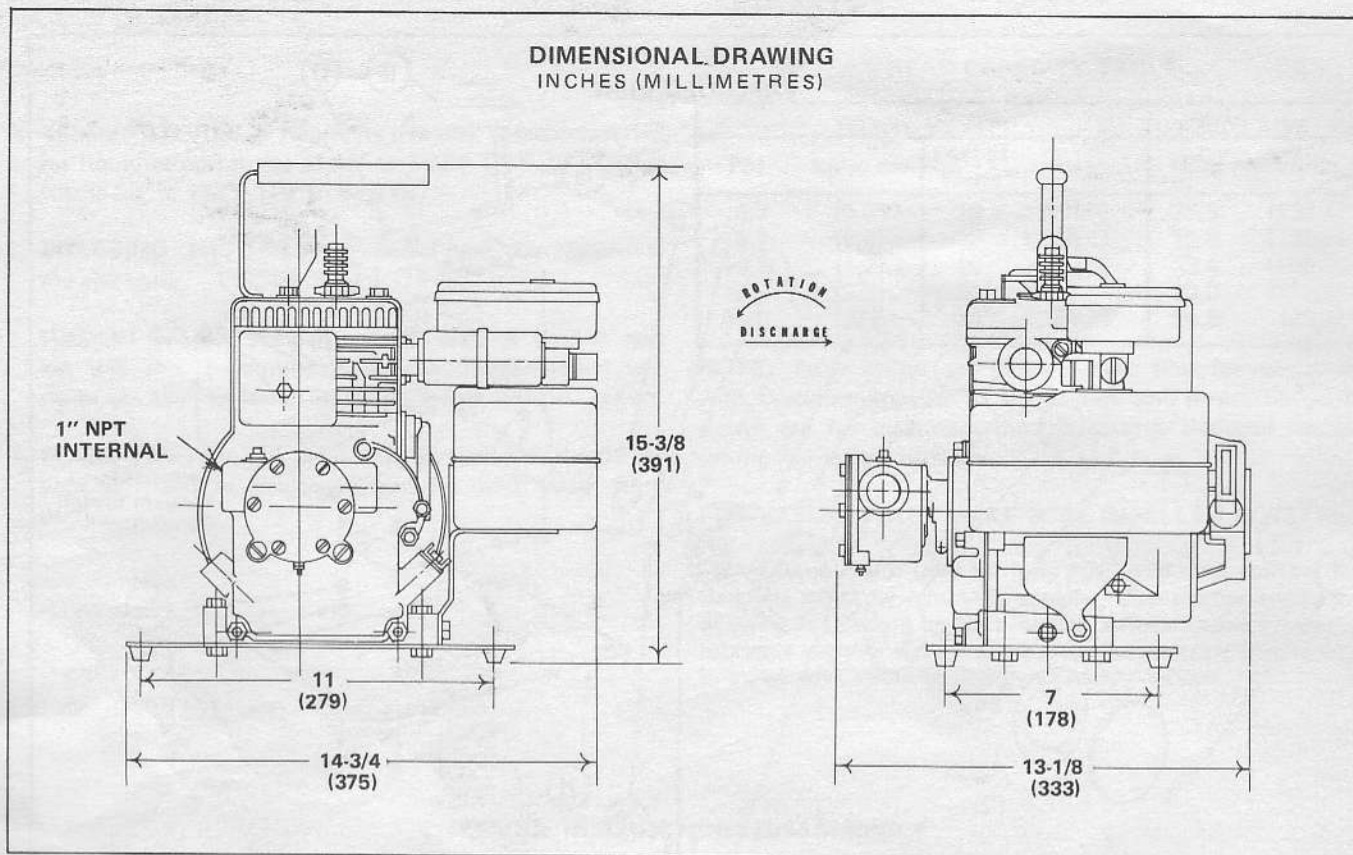

**TO EQUIP WITH VACUUM SWITCH 4732-0010**

1. Install switch in tapped hole on top of inlet port with nipple provided. Apply thin coating of sealant to threads prior to assembly.
2. Connect switch to motor. See exploded view.
3. To operate, start engine with restart lever in the hold-down position until the pump proceeds to prime.

**SPECIAL ATTENTION**

1. Constant vibration of the restart lever indicates:
  - (A) **An air leak.** This will usually show up when the pump is first started. All suction lines should be checked for loose connections.
  - (B) **A worn impeller.** Impeller should be replaced.
2. Intermittent stopping and starting indicates that the unit is operating against excessive discharge pressure.

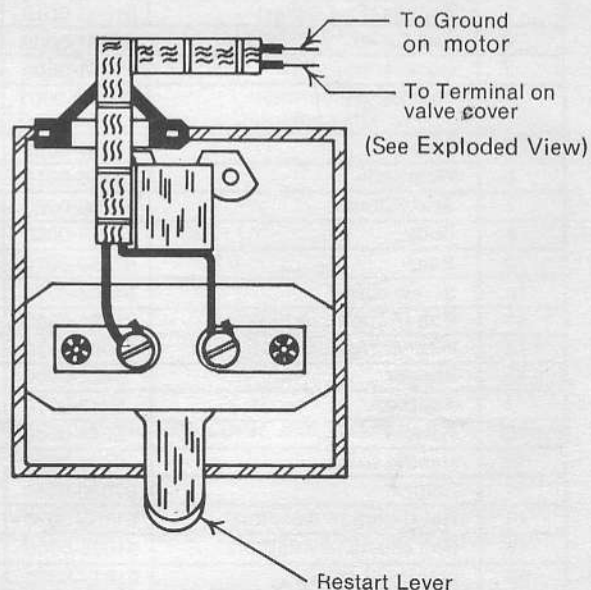

**Wiring Diagram for Vacuum Switch**

**THE PRODUCT DESCRIBED HEREIN IS SUBJECT TO THE JABSCO ONE YEAR LIMITED WARRANTY, WHICH IS AVAILABLE FOR YOUR INSPECTION UPON REQUEST.**

**ITT Jabsco**

ITT Fluid Technology Corporation  
1485 Dale Way, P.O. Box 2158, Costa Mesa, CA 92628-2158  
Tel: (714) 545-8251; Fax: (714) 957-0609  
Bingley Road, Hoddesdon, Hertfordshire EN11 0BU England  
Tel: 0992-467191; Tlx: 263251 G; Fax: 0992-467132