

JABSCO

Model 5600-SERIES

Model 5600-SERIES

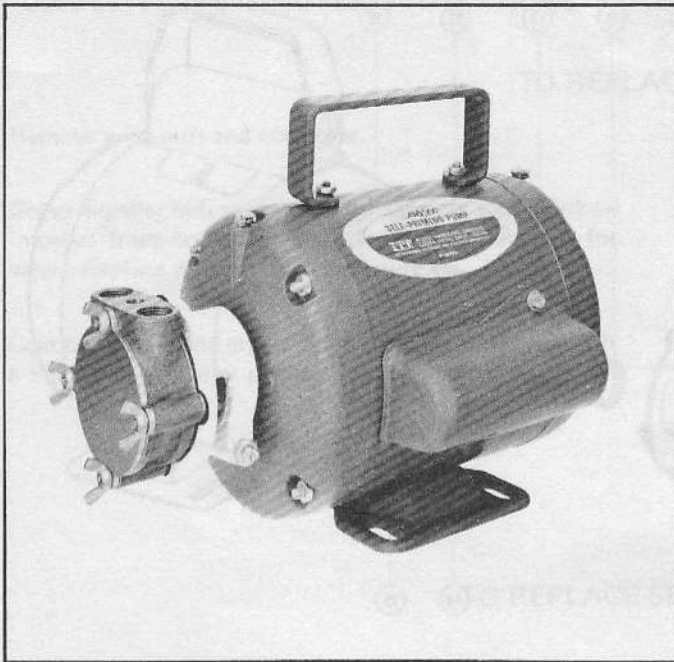

SELF-PRIMING PUMPS

FEATURES

Body:	Stainless Steel
Impeller:	Neoprene, Nitrile, Viton*
Shaft:	Motor Shaft Protected by Stainless Steel Impeller Sleeve
Wearplate:	Replaceable
Shaft Seal:	Lip Seal
Port:	3/8" NPT, Internal
Motor:	1/4 HP T.E.N.V. Capacitor Type Overload Protector, 1725 RPM 60 Cycles, Single Phase, 115 VAC, 6' Cord and Plug
Weight:	27 lb (12, 3 kg)

VARIATIONS AVAILABLE

Model	Description
5600-0001	Neoprene Impeller
5600-0003	Nitrile Impeller
5600-0004	Viton Impeller, O-Rings & Seal

MOTOR WARNING



MOTOR CAN SPARK.
EXPLOSION & DEATH
CAN OCCUR.
DO NOT USE WHERE
FLAMMABLE VAPORS
ARE PRESENT.

TYPICAL APPLICATIONS

INDUSTRIAL: Circulating and transferring corrosive liquids. Returning spilled liquids to process. Transferring foaming solutions with entrained air, such as soaps and detergents. Industrial and processing systems. Ideal for sampling and pilot plant installations. Circulating non-abrasive slurries. Transferring inks, dyes, sizes, starches, etc. Circulating through various-type filters.

PHARMACEUTICAL: Processing medicines, lotions, preparations. Filtering pharmaceutical solutions.

CHEMICAL: Circulating and transferring various chemicals such as alcohols, ammonia, barium, copper sulphate, cyanide solutions, silver nitrate, sodium bicarbonate, sodium thio-sulphate.

Circulating and transferring various acids such as boric, carbonic, citric, phosphoric, etc. Circulating photo processing solutions including fix and developer. Recirculating through electro-plating filters. Circulating and transferring alkaline solutions.

OPERATING INSTRUCTIONS

INSTALLATION — Pump may be installed in any position. The intake port is on the right when looking at pump end cover.

SELF-PRIMING — Vertical, dry suction lift of 10'. Pump will produce suction lift up to 22' when wet. **BE SURE SUCTION LINES ARE AIRTIGHT** or pump will not self-prime.

DISCHARGE — When transferring liquids further than 25', use 1/2" I D discharge line.

RUNNING DRY — Unit depends on liquid pumped for lubrication. **DO NOT RUN DRY FOR MORE THAN 30 SECONDS.** Lack of liquid will damage the impeller and seal.

NOTICE — When corrosive fluids are handled, pump life will be prolonged if pump is flushed with water after each use or after each work day. For further information, consult Jabsco Chemical Resistance Table (available upon request from ITT Jabsco) or factory.

PRESSURES—For continuous operation, pressure should not exceed 20 psi (1,4 kg/cm²) for Neoprene and Nitrile impellers and 17 psi (1,2 kg/cm²) for Viton impellers.

TEMPERATURE — Neoprene impeller 45° to 180° F (7° - 82° C), Nitrile impeller 50° to 180° F (10° - 82° C), Viton impeller 60° to 180° F (15° - 82° C).

SPARE PARTS — A Jabsco Service Kit should be kept on hand to maintain all but the most badly worn pumps.

Viton* is a trademark of E. I. Du Pont de Nemours and Company.

EXPLODED VIEW

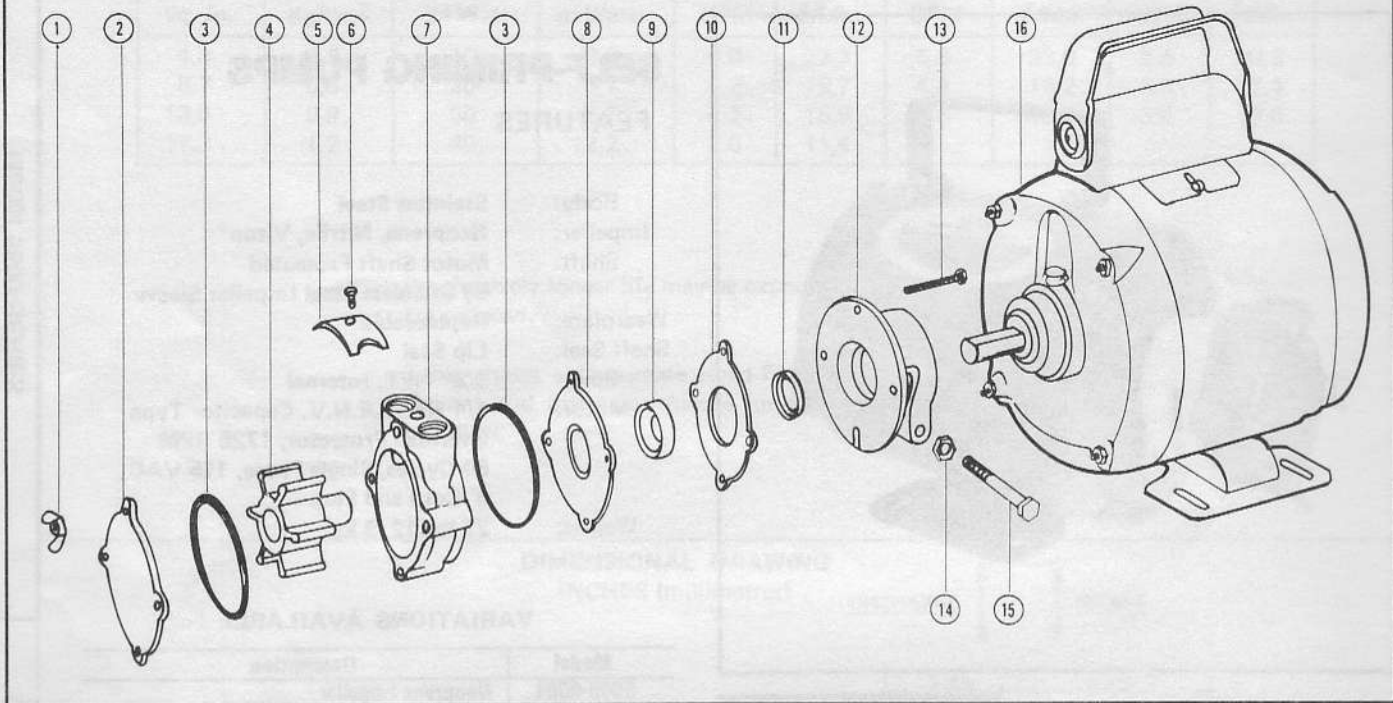

PARTS LIST

Key	Part Number	Description	Qty. Req.
1	91107-0010	Wing Nuts	4
2	12061-0000	End Cover	1
3	92000-0410	O - Ring	2
	92000-0770	O - Ring (Viton)	
4	5606-0001	*Impeller Assembly - Neoprene	1
	5606-0003	Impeller - Nitrile	
	5606-0004	Impeller - Viton	
5	900-0000	Cam	1
6	91041-0010	Cam Screw	1
7	864-0000	Body	1
8	891-0000	Wear Plate (Body to Adaptor)	1
9	92700-0660	*Seal (Shaft)	1
	92700-0940	Seal (Shaft) - Viton	
10	5065-0000	*Seal (Liner)	1
11	6946-0000	Slinger	1
12	5604-0000	Adaptor	1
13	91093-0010	Bolt (Body)	4
14	91105-0030	Hex Nut	1
15	91095-0090	Bolt	1
16	18737-0000	Motor Assembly	1

SERVICE KITS

MODEL	REPLACEMENT PUMP HEAD	SERVICE KIT
5600-0001	5608-0001 Neoprene Impeller	90052-0001 Neoprene Impeller
5600-0003	5608-0003 Nitrile Impeller	90052-0003 Nitrile Impeller
5600-0004	5608-0004 Viton Impeller	90052-0014 Viton Impeller O-Ring & Seal

*Contained in Service Kit

SERVICE INSTRUCTIONS

● DISASSEMBLY AND □ ASSEMBLY INSTRUCTIONS

CAUTION: PUMPS WHICH HAVE HANDLED CORROSIVE, CAUSTIC OR TOXIC FLUIDS SHOULD BE DRAINED AND COMPLETELY FLUSHED PRIOR TO SERVICING. FAILURE TO DO SO MAY CAUSE INJURY.

TO REPLACE IMPELLER

- Remove wing nuts and end cover.
- Grasp impeller hub with water pump pliers and withdraw impeller from body. Check seal and internal parts for wear. Replace worn parts, if necessary.
- Coat body bore and end of impeller extended insert with a light film of water pump grease. Align detent in impeller extended insert with keyway in shaft. Depress the two impeller blades which fit under the cam, and carefully push the impeller into the body bore. Use a screw driver in the drain slot area to push the neoprene slinger up onto the end of the extended impeller. Rotate the impeller in a clockwise direction (looking at end cover) to assure the impeller blades are in the correct position for easy starting.
- Replace end cover and secure with wing nuts.

TO REPLACE SEAL ASSEMBLY

- Loosen adaptor clamp nut and remove pump head from motor. Use a screw driver to spread the clamp slightly to facilitate removal.
- Remove wing nuts, end cover and bolts.
- Remove body and wearplate from adaptor. Push impeller from body bore.
- Remove seal liner and seal by pressing from motor end of adaptor.
- Remove seal from liner. Check all parts for wear. Replace if questionable.
- Install seal liner in bore of adaptor, aligning bolt holes carefully.
- Dip lip seal in water for lubrication and push into seal liner bore with lip of seal facing outwards. Wipe a thin film of grease on lip of seal.
- Install wearplate against liner, with lube slot located in bottom of impeller bore. Align bolt holes.
- Push the impeller into the body and rotate the impeller in a clockwise direction to align the blades for correct direction of rotation. Make sure the O-rings are in the grooves in the flange faces of the body. Place the body on the wearplate while carefully inserting the impeller extended insert through the seal.
- Install bolts through adaptor flange and body. Make sure O-ring is in place in body groove. Wipe a thin film of grease or petrogel on impeller face. Install end cover over four bolts and secure with wing nuts.
- Push the slinger part way onto the shaft.
- Align the detent in the impeller extended insert with the keyway in the shaft and push the pump head onto the motor hub, firmly against the motor. Tighten the adaptor clamp nut just enough to prevent the pump head from turning on the motor hub. If too tight, motor bearing will seize the shaft and become damaged during operation.
- Assurance of proper operation may be obtained by connecting two short hoses to the intake and discharge ports. Hang the hose ends in a water container and start pump. Swirling of water indicates proper pump operation.

HEAD CAPACITY TABLE

Total Head				Flow at 1725 RPM					
Lbs. per Sq. In.	Kg/cm ²	Feet of Water	Metres of Water	Neoprene		Nitrile		Viton	
				GPM	l/Min	GPM	l/Min	GPM	l/Min
4.3	0,3	10	3,0	6.0	22,7	5.8	22,0	5.5	20,8
8.7	0,6	20	6,1	5.2	19,7	4.8	18,2	4.6	17,4
13.0	0,9	30	9,1	4.2	15,9	3.6	13,6	3.6	13,6
17.3	1,2	40	12,2	3.0	11,4				

Progressively longer life may be expected as operating pressures are reduced.

Table shows approximate Head-Flow for new pump in U.S. Gallons and Litres per minute for neoprene, nitrile and viton impellers.

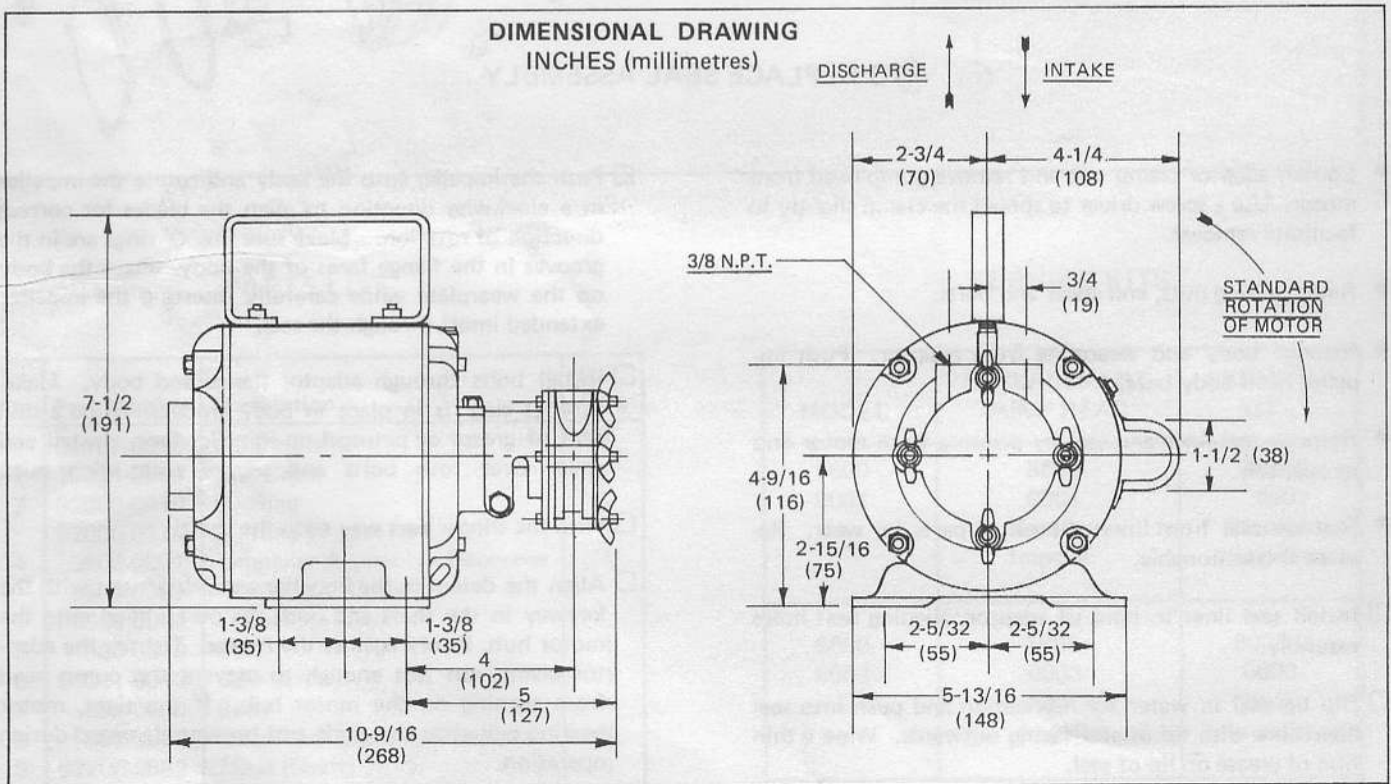

THE PRODUCTS DESCRIBED HEREIN ARE SUBJECT TO THE JABSCO ONE YEAR LIMITED WARRANTY, WHICH IS AVAILABLE FOR YOUR INSPECTION UPON REQUEST.

Jabsco
 ITT Fluid Technology Corporation
 1485 Dale Way, P.O. Box 2158
 Costa Mesa, California 92628-2158
 Telephone: (714) 545-8251