

MODEL: 5560-0001

DESIGN FEATURES

- Body: **Bronze**
- Impeller: **Neoprene**
- Shaft: **Alum. Silicon Bronze**
- Seal: **Lip-Type**
- Ports: **1" NPT Inlet**
- Weight: **8 lbs. (Approx.)**

APPLICATION:

Marine Engine Cooling

Model 5560-0001 for Gray Marine Fireball V-8 R. H.
(VHC 280, VHC 310 R. H.)
Model 5660-0001 for Gray Marine Fireball V-8 L. H.
(VHC 280, VHC 310 L. H.)

MODEL: 5660-0001

DIMENSIONAL DRAWING

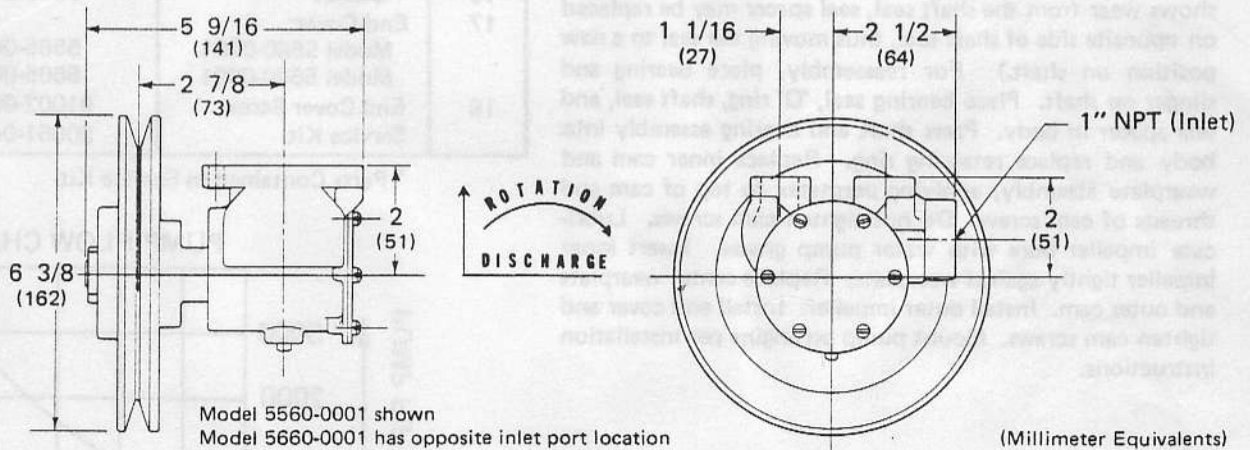

INSTALLATION INSTRUCTIONS

The mounting face gasket and mounting bolts for these pumps are not supplied by Jabsco. On installation, be sure mounting face is clean to insure a proper discharger port seal. Install pump in same position as original pump. Complete installation by connecting inlet fitting and installing drive belt.

OPERATING INSTRUCTIONS

Pump will self-prime at low or high speeds. Make sure scoop and inlet line are clear and all connections air tight. Do not run pump dry for more than 30 seconds. Lack of water flow may damage impellers. To drain pump, remove drain plug.

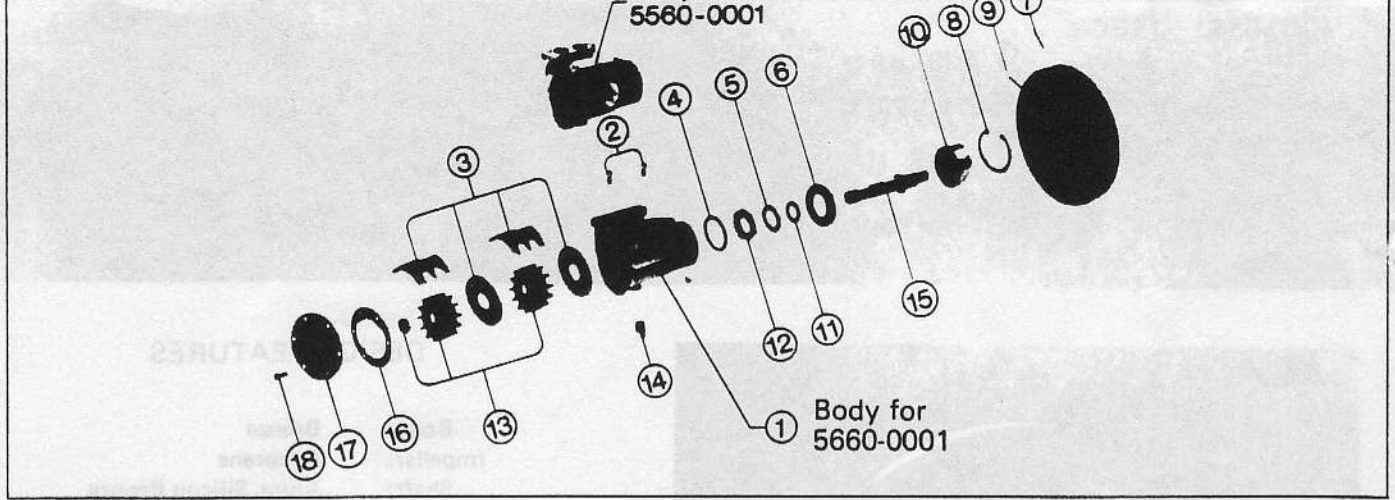

SERVICE INSTRUCTIONS

Impeller Replacement: Remove pump from engine. Remove end cover screws, end cover and gasket. Remove outer impeller by grasping hub with water pump pliers. Loosen outer cam screw, tap screw to loosen cam, and remove screw and cam. Clean permatex off cam and cam screw. Remove center wearplate and inner impeller. Lubricate impeller bore with water pump grease. Install new inner impeller. Install center wearplate and outer cam, applying fresh permatex to top of cam and cam screw. Install outer impeller. Install spline seal. Replace end cover gasket, end cover, and end cover screws.

Major Repair: Remove pump from engine. To disassemble pump, remove end cover, impellers, cams and wearplates. Remove roll pin and press off pulley. Remove bearing retaining ring and press shaft and bearing out bearing bore. Remove bearing seal, lip seal, 'O' ring, and seal spacer from body. Replace worn or damaged parts. (NOTE: If shaft shows wear from the shaft seal, seal spacer may be replaced on opposite side of shaft seal, thus moving the seal to a new position on shaft.) For reassembly, place bearing and slinger on shaft. Place bearing seal, 'O' ring, shaft seal, and seal spacer in body. Press shaft and bearing assembly into body and replace retaining ring. Replace inner cam and wearplate assembly, applying permatex to top of cam and threads of cam screw. Do not tighten cam screws. Lubricate impeller bore with water pump grease. Insert inner impeller tightly against wearplate. Replace center wearplate and outer cam. Install outer impeller. Install end cover and tighten cam screws. Mount pump on engine per installation instructions.

PARTS LIST

KEY	DESCRIPTION	PART NO.	QTY.
1	Body:		
	Model 5560-0001	5564-0000	1
	Model 5660-0001	5664-0000	1
2	Cam Screw	91003-0010	2
3	Cam & Wearplate	7607-0000	2
4	* 'O' Ring	92000-0210	1
5	* Seal Spacer	3166-0000	1
6	Bearing Seal	913-0000	1
7	Roll Pin	93100-0040	1
8	Retaining Ring	91701-1850	1
9	Pulley	5668-0000	1
10	Ball Bearing	92600-0060	1
11	Slinger	3286-0000	1
12	* Shaft Seal	92700-0060	1
13	* Impeller	1210-0001	2
14	Pipe Plug	92650-0040	1
15	Shaft	5567-0000	1
16	* Gasket	3298-0000	1
17	End Cover:		
	Model 5560-0001	5565-0000	1
	Model 5660-0001	5665-0000	1
18	End Cover Screw	91002-0020	6
	Service Kit	90051-0001	

* Parts Contained in Service Kit

PUMP FLOW CHART

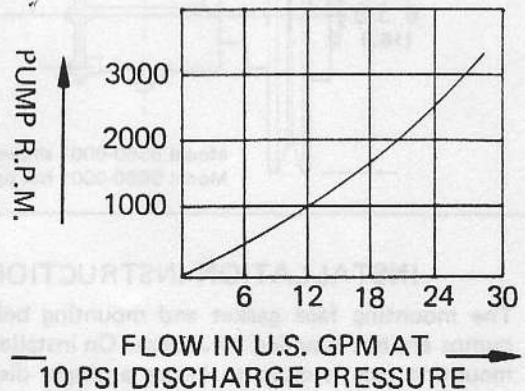

JABSCO PRODUCTS **ITT**

Marine and Recreation Components Division
International Telephone and Telegraph Corporation
1485 Dale Way, Costa Mesa, California 92626

Telephone: (714) 545-8251