

JABSCO® PUMPS

Self Priming Pumps

MODEL: 5330-9001

Product Data

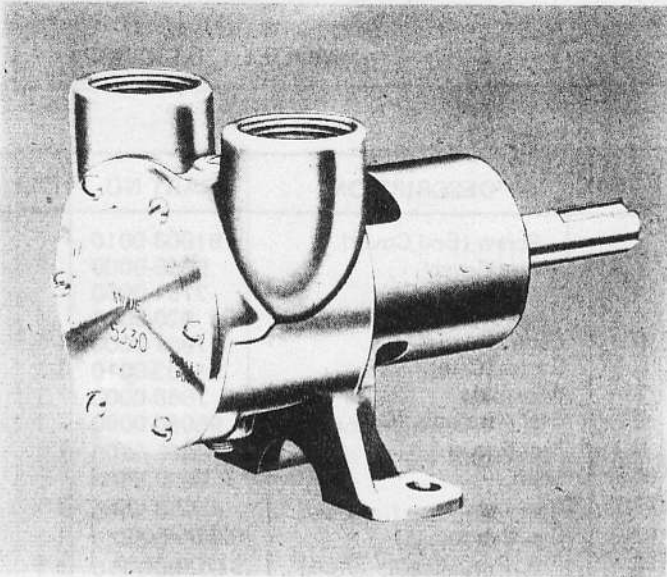

MODEL 5330-9001

DESIGN FEATURES

Body:	Bronze
Impeller:	Jabco Neoprene Compound
Shaft:	316 Stainless Steel
Shaft Seal:	Carbon-Ceramic Face Type
Ports:	1" NPT
Weight:	Approx. Shipping Wght. 7 lbs.

APPLICATION:
Marine Engine Cooling

FOR ENGINE MODELS:

Grummen Allied Ind. D155H, G110V
Harnischfeger V463
Revley Corp. R401J

MODEL: 5330-9001

DIMENSION DRAWING

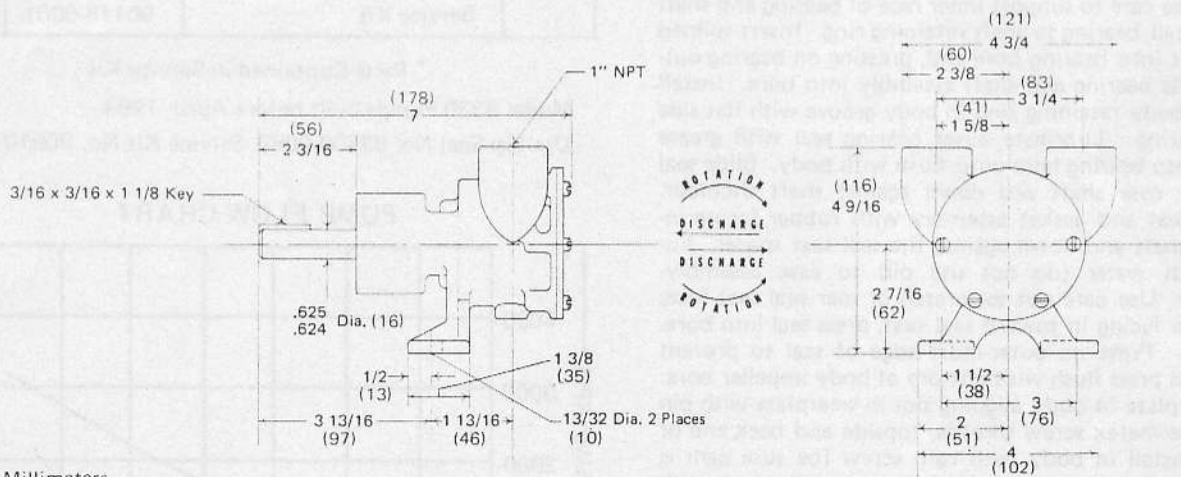

INSTALLATION INSTRUCTIONS

Pump may be mounted in any position. The rotation of the pump shaft determines the location of the pump's intake and discharge ports (refer to dimensional drawing). Before installing, turn the pump shaft in the direction of the operating rotation.

DRIVE - Belt or Direct with flexible coupling.

BELT DRIVE - Overtight belt load will reduce pump bearing life.

DIRECT DRIVE - Clearance should be left between drive shaft and pump shaft when installing coupling. Always

mount and align pump and drive shaft before tightening the coupling set screw. Do not hammer coupling or pulley onto shaft; ceramic seal seat may be damaged. If drive is pressed on shaft, be sure to remove end cover and impeller to support end of shaft.

OPERATING INSTRUCTIONS

Pump will self prime at low or high speeds. Make sure scoop and inlet line are clear and all connections air tight. Do not run pump dry for more than 30 seconds. Lack of water flow may damage impeller. To drain pump, loosen end cover screws.

EXPLODED VIEW

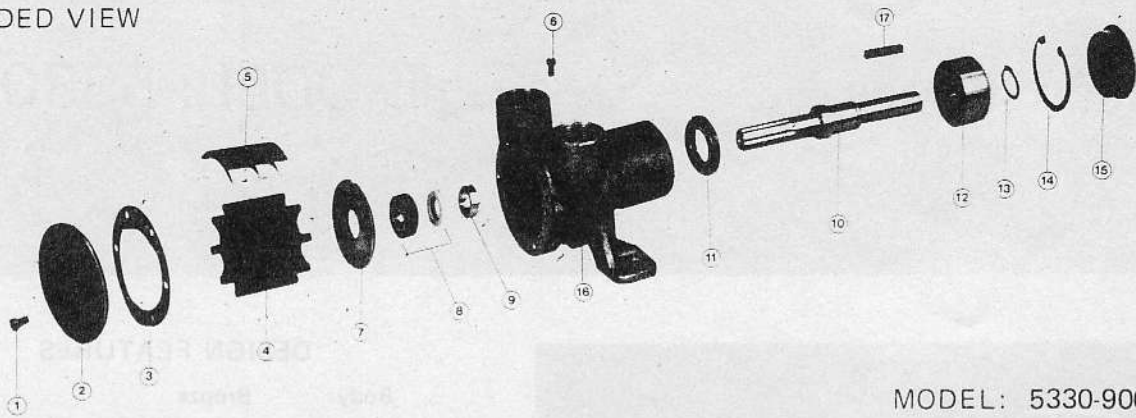

MODEL: 5330-9001

SERVICE INSTRUCTIONS

IMPELLER REPLACEMENT: Remove end cover and gasket. Pull impeller out by grasping hub or blades with pliers. Replace impeller, gasket and end cover. A light coating of grease in impeller bore will aid priming on dry start up. (Use correct Jabsco gasket; a thicker or thinner gasket may cause impeller damage.) Standard gasket is .010" thick.

MAJOR REPAIR: Remove pump from engine to replace seal, bearings or shaft. Completely disassemble pump, remove outer bearing seal (Key No. 15). Remove bearing to body retaining ring. Pressing on impeller end of shaft, remove shaft and bearing assembly. Remove seal seat, seal seat gasket, and seal seat spacer from shaft. Remove bearing to shaft retaining ring. Supporting bearing inner race, press shaft through bearing. Remove seal from seal bore by pressing from bearing bore end toward the body impeller bore.

TO ASSEMBLE: Lubricate inner bearing seal with water pump grease, or equivalent, and press into body bearing seal bore with the lip facing away from bearing. Press shaft into bearing. Use care to support inner race of bearing and shaft sleeve. Install bearing to shaft retaining ring. Insert splined end of shaft into bearing bore and, pressing on bearing outer race, press bearing and shaft assembly into bore. Install bearing to body retaining ring in body groove with flat side toward bearing. Lubricate outer bearing seal with grease and press into bearing bore until flush with body. Slide seal seat spacer over shaft and down against shaft shoulder. Slide seal seat and gasket assembly with rubber facing inward over shaft and down against the seal seat spacer. Lubricate with water (do not use oil) to ease assembly. **CAUTION:** Use care not to scratch or mar seal seat face. With carbon facing in toward seal seat, press seal into bore. **CAUTION:** Press on outer-most edge of seal to prevent damage, and press flush with bottom of body impeller bore. Install wearplate in body aligning slot in wearplate with pin in body. Permatex screw threads, topside and back end of cam, and install in body with cam screw (be sure cam is flush with end cover surface). Lubricate impeller bore with a light coat of water pump grease, and start impeller into bore with a rotary motion until splines engage, then push into bore. Install gasket and end cover, and secure with cover screws.

KEY	DESCRIPTION	PART NO.	QTY.
1	Screw (End Cover)	91003-0010	6
2	End Cover	5335-9000	1
3*	Gasket	3101-0000	1
4*	Impeller	920-0001	1
5	Cam	7867-0000	1
6	Screw (Cam)	91003-0010	1
7	Wearplate	7868-0000	1
8*	Seal Assembly (Complete)	96080-0080	1
9	Seal Spacer	12005-0000	1
10	Shaft	5337-0000	1
11	Bearing, Seal (Inner)	913-0000	1
12	Ball Bearing	92600-0060	1
13	Ret. Ring (Brg. to Shaft)	91700-2470	1
14	Ret. Ring (Brg. to Hsg.)	91701-1850	1
15	Bearing Seal (Outer)	914-0000	1
16	Body	3784-9000	1
17	Key (Pump Drive)	9215-0000	1
	Service Kit	90118-0001	

* Parts Contained in Service Kit

Model 5330 Pumps built before April, 1964 -

Use Lip Seal No. 92700-0060, Service Kit No. 90010-0001

PUMP FLOW CHART

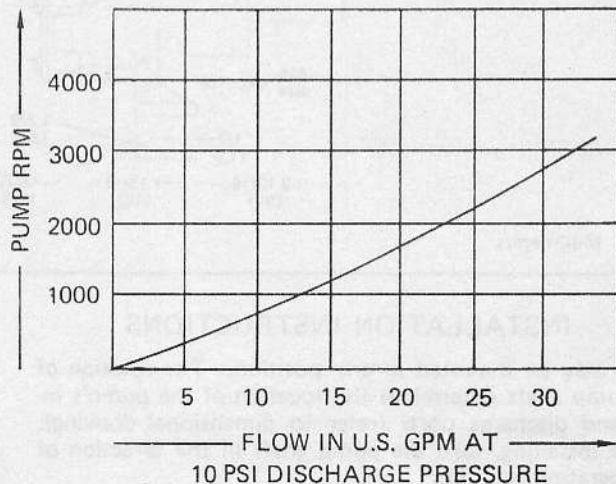

JABSCO PRODUCTS **ITT**

Marine and Recreation Components Division, International Telephone and Telegraph Corporation
1485 Dale Way, Costa Mesa, California 92626

Telephone: (714) 545-8251