



270 Size Bronze Flexible Impeller Pump Head Kit

2/99

53270 Series

Bronze Flexible Impeller Pump

Features

- Flows up to 270 Litres/Minute @ 1500 RPM
- Self prime from dry up to 4.5 metres
- Handles hard or soft solids
- Non pulsating flow
- Gentle pump action does not damage shear-sensitive products
- Easy to service and maintain

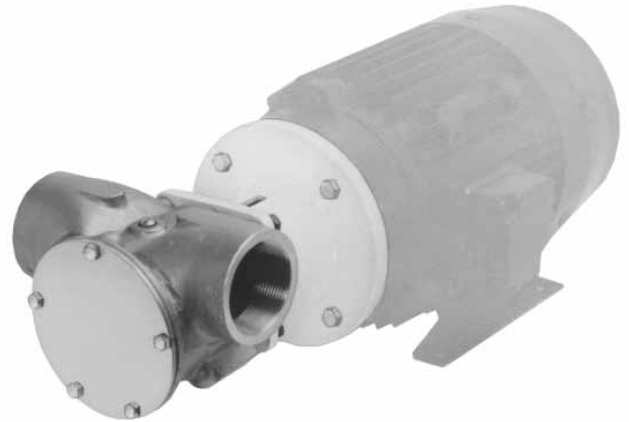

Typical Applications

Industrial : From water to the most difficult, e.g. transferring foaming solutions with entrained air or solids, such as soap, circulating abrasive and non abrasive slurries. Transferring inks, dyes, starches etc.

Chemical : Circulating and transferring various chemicals such as ammonia, barium, copper sulphate, glycerine, nickel chloride, silver nitrate; various acids such as boric, carbonic, citric and photo processing solutions, widely used for polyelectrolyte.

Model Options

Impeller option	Neoprene	Nitrile
Temperature range	4°C to 80°C	-5°C to 90°C
Pump head only	53270-2011	53270-2013

Note : it is not recommended to start the pump at extreme ends of the temperature range, impeller damage may occur

All models use Nitrile seal elastomers

Other options available, Pedestal & Motor pump units, in Bronze, Plastic & Stainless steel

Specifications

Seal : Carbon/Ceramic mechanical seal

Pump Head : Bronze

End Cover : Brass

Bearings : Uses motor bearings

Shaft : 316 Stainless steel shaft extension

Motor adaptor : Epoxy-coated aluminium, suitable for B3/B14 D100 frame motor to IEC 71 standard

Ports : 2" BSP internal thread

Weight : 9.3kg.

For Installation, Operating, Maintenance and Safety Instructions refer to form 43001-0543

WARNING Explosion hazard. Do not pump gasoline, solvents, thinners or other flammable liquids. To do so can cause an explosion resulting in injury or death.



WARNING Injury hazard. Exposed pulleys and belts can cause injury. Install shield around pulleys and belts. Stay clear while machinery is operating.



53270 Series

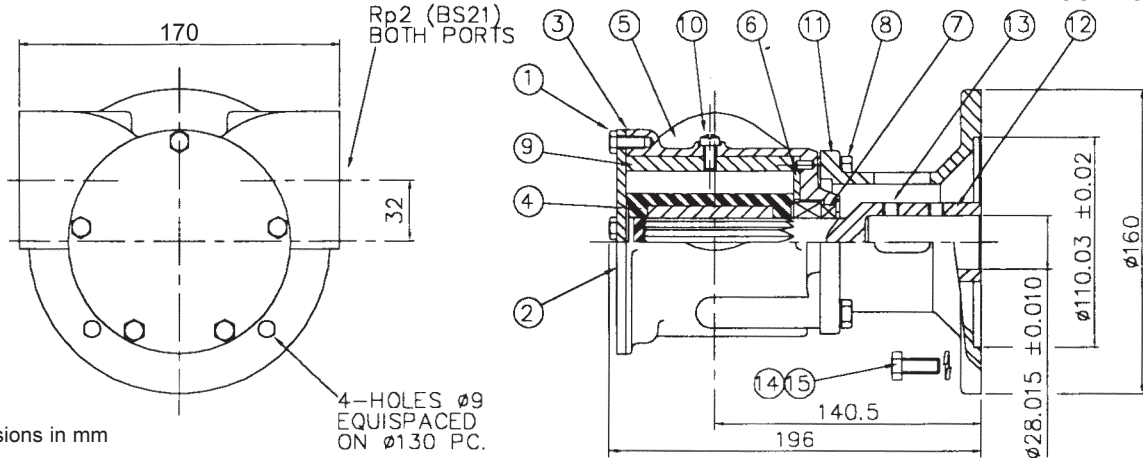

Dimensions in mm

Parts List

Key	Description	Qty	Part No.
1	Screw*	5	X3001-176F
2	Endcover	1	9336
3	Gasket*	1	816
4	Impeller*	1	17936-0001
5	Body	1	50274-2100
6	Wearplate	1	2574
7	Seal assembly*	1	21849
8	Screw	4	X3001-209C
8a	Washer	4	X3081-101C
9	Cam	1	6988
10	Screw	Cam	1 SP1005-04
11	Adaptor	1	22884
12	Extension	Shaft	1 22887-01
13	Screw	Set	2 X3009-203A
14	Screw	4	X3001-209C
15	Washer	4	X3081-101C

Parts marked * above are contained in a Service kit
 Service kit 1 SK408-0011

Mechanical seals are fitted with Nitrile elastomers.

Performance

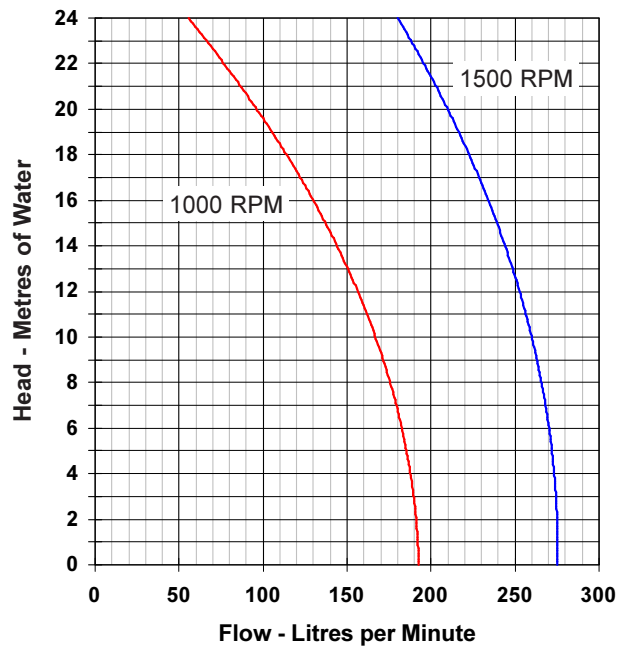

Note : Performance shown is for a new pump, fitted with a Neoprene impeller, pumping water at 20°C, performance may vary by up to 15%. Consult factory for performance of alternative impeller compounds.

Jabsco



ITT Industries

USA

Jabsco
 1485 Dale Way
 Costa Mesa
 CA 92628-2158

Tel : +1 714 545 8251
 Fax : +1 714 957 0609

UK

Jabsco
 Bingley Road
 Hoddesdon
 Hertfordshire, EN11 0BU

Tel : +44 (0) 1992 450 145
 Fax : +44 (0) 1992 467 132

GERMANY

Jabsco GmbH
 Oststraße 28
 22844 Norderstedt

Tel : +49 (0) 40 53 53 73 0
 Fax : +49 (0) 40 53 53 73 11