

**JABSCO**<sup>®</sup>

# Models 485-SERIES 1270-SERIES

MODELS 485-SERIES, 1270-SERIES

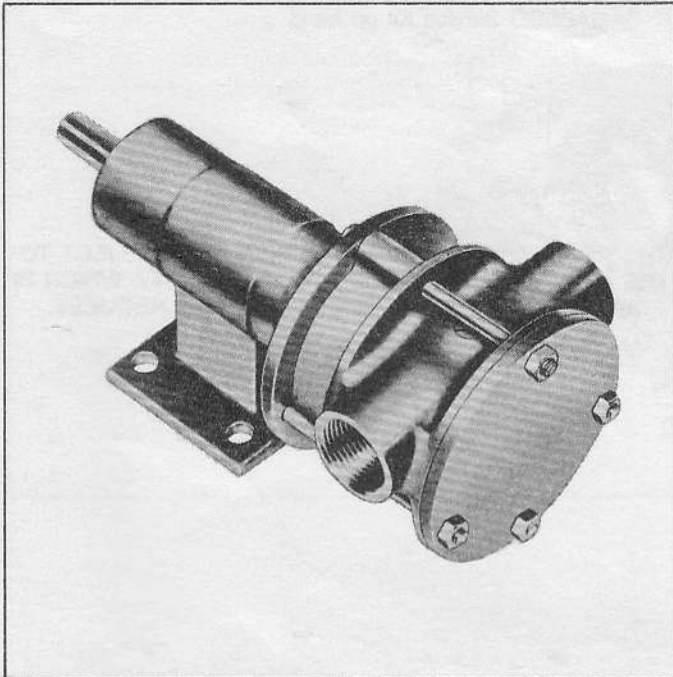

## SELF-PRIMING PUMPS FEATURES

<b>Body:</b>	Type 316 Stainless Steel
<b>Impeller:</b>	Neoprene or Nitrile
<b>Wearplate:</b>	Replaceable
<b>Shaft:</b>	Type 316 Stainless Steel
<b>Shaft Seal:</b>	Mechanical Carbon-Stainless Steel, Nitrile
<b>Bearings:</b>	Sealed, Prelubricated Ball Bearings
<b>Pedestal:</b>	Model 485 – Type 316 Stainless Steel Model 1270 – Cast Iron - Painted
<b>Ports:</b>	1" NPT Internal
<b>Weight:</b>	10 lbs. (4,5 kg) (approx.)

Model	Description
485-0001	Neoprene Impeller
485-0003	Nitrile Impeller
1270-0001	Neoprene Impeller
1270-0003	Nitrile Impeller

## APPLICATIONS

**INDUSTRIAL:** Circulating and transferring, velocity-mixing, pumping machine tool coolants, return spill, sump drainage, chemicals, pharmaceuticals, soap, liquors, ink, dyes, alcohol, dilute acids, tanning liquors, glycerine, brine, etc.

**PHARMACEUTICAL:** Processing medicines, lotions, preparations. Filtering pharmaceutical solutions.

**PAPER PROCESSING:** Transferring and applying starches, sizes, etc. Circulating and processing wood pulp slurries.

**FOOD, BEVERAGE & DAIRY:** Transfer brines, vinegar, syrups during processing, liquids containing solids in suspension such as chopped tomatoes, nuts, etc. Removal of distillery wort and brewery slop. Processing viscous materials such as peanut butter, mayonnaise, ketchup, honey, etc. (low speed). Pumping whiskey, wine and rums.

**AGRICULTURAL:** Transferring liquid fertilizers and components.

## OPERATING INSTRUCTIONS

- 1. INSTALLATION** – Pump may be mounted in any position. The rotation of the pump shaft determines the location of the pump's intake and discharge ports. (Refer to dimensional drawing.) Pump is normally assembled at factory for clockwise rotation (looking at end cover). If counter clockwise rotation is desired, follow steps 1 and 2 of disassembly and step 11 of assembly instructions to change direction of impeller blade deflection under cam.
- 2. DRIVE** – Belt or Direct with flexible coupling.  
 Belt Drive: Overtight belt load will reduce pump bearing life.  
 Direct Drive: Clearance should be left between drive shaft and pump shaft when installing coupling. Always mount and align pump and drive shaft before tightening the coupling set screw.  
 If pulley or coupling must be pressed on shaft, remove end cover and impeller to support shaft from impeller end during press operation. Do not hammer pulley or coupling on shaft; this may damage bearing or seal.
- 3. SPEEDS** – 100 RPM to the maximum shown in the performance table. Consult the factory for operation at speeds above those shown. For longer pump life, operate at lowest possible speeds.

4. SELF-PRIMING – Primes at low or high speeds. For vertical dry suction lift of 10 feet, a minimum of 800 RPM is required. Pump will produce suction lift of up to 22 feet when wetted. BE SURE SUCTION LINES ARE AIRTIGHT OR PUMP WILL NOT SELF-PRIME.
5. RUNNING DRY – Unit depends on liquid pumped for lubrication. DO NOT RUN DRY for more than 30 seconds. Lack of liquid will damage the impeller.
6. NOTICE – Do not pump light fraction petroleum derivatives, solvents, thinners, highly concentrated or organic acids. Damage to pump may result. Consult Jabsco Chemical Resistance Table (available upon request from ITT Jabsco) or factory for proper body materials and impeller compounds. If corrosive fluids are handled, pump life will be prolonged if pump is flushed with water after each use or after each work day.
7. PRESSURES – Consult Head Capacity Table for recommended maximum for continuous operation. If pressures exceed those shown, consult the factory.
8. TEMPERATURES – Neoprene 45° - 180°F (7° - 82°C), Nitrile 50° - 180°F (10° - 82°C).
9. GASKET – Use a standard pump part. Thicker gasket will reduce priming ability. A thinner gasket will cause the impeller to bind. Standard gasket is 0.010" thick.
10. SPARE PARTS – To avoid costly shutdowns, keep a JABSCO Service Kit on hand.

**WARNING: EXPOSED PULLEY AND BELTS CAN CAUSE INJURY, INSTALL SHEILD AROUND PULLEYS AND BELTS.**

**THE PRODUCTS DESCRIBED HEREIN ARE SUBJECT TO THE JABSCO ONE YEAR LIMITED WARRANTY, WHICH IS AVAILABLE FOR YOUR INSPECTION UPON REQUEST.**

**WARNING: DO NOT PUMP SOLVENTS, THINNERS, OR GASOLINE AS EXPLOSION MAY RESULT CAUSING INJURY OR DEATH.**

**DIMENSIONAL DRAWING**  
Inches (millimeters)

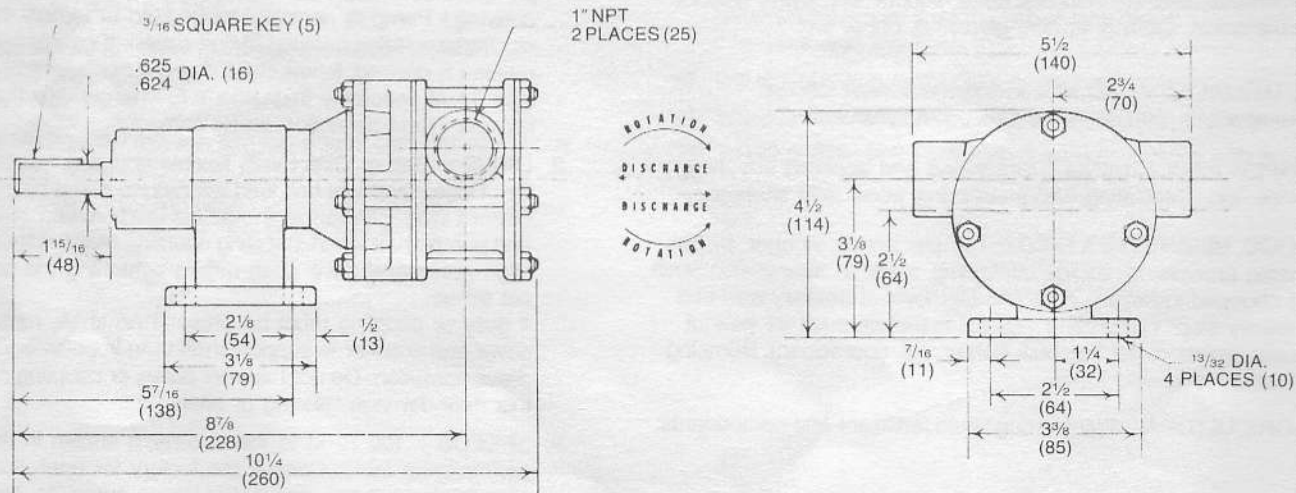

### EXPLODED VIEW

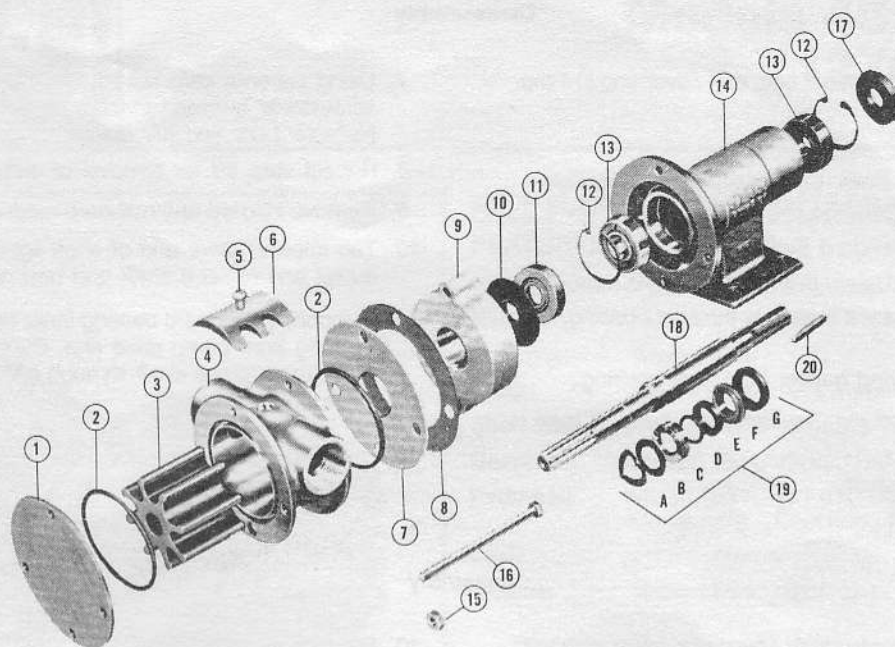

### PARTS LIST

Key	Description	Part Number	Qty. Req.	Key	Description	Part Number	Qty. Req.
1	End Cover (485 Version)	4725-0000	1	12	Retaining Ring	91700-2500	2
	End Cover (1270 Version)	8999-0000		13	Ball Bearings	92600-0120	2
2	O-Ring	92000-0310	2	14	Pedestal - Stn. Stl. Pedestal - Cast Iron	492-0000 1269-0000	1
3	*Impeller (Neoprene)	964-0001	1	15	Hex Nut	91085-0050	4
	*Impeller (Nitrile)	964-0003		16	Bolt	91094-0120	4
4	Body	468-0000	1	17	Bearing Seal (Outer)	496-0000	1
5	Screw (Cam)	91030-0020	1	18	Shaft	949-0000	1
6	Cam	1029-0000	1	19	*Seal (Carbon Stn. Stl.)	1816-0000	1
7	Wearplate	6483-0000	1	20	Key (Pump Drive)	91402-0110	1
8	*Gasket (Wearplate)	6503-0000	1	Service Kits 485-0001, 1270-0001		90008-0001	
9	Seal Housing (Standard)	955-0000	1	Service Kits 485-0003, 1270-0003		90008-0003	
10	Slinger	5592-0000	1				
11	Bearing Seal (Inner)	496-0000					

\* Parts supplied in Service Kits.

### HEAD CAPACITY TABLE

TOTAL HEAD		500 RPM		1160 RPM		1750 RPM	
LBS. PER SQ. FT.	FT. OF WATER	GPM	H/P	GPM	H/P	GPM	H/P
4.3	10	6.8	1/4	16.5	1/3	26.0	3/4
8.7	20	6.3	1/4	15.9	1/2	24.5	3/4
17.3	40	4.7	1/4	13.5	1/2	20.0	3/4
26.0	60	-	-	9.5	3/4	16.5	1
30.3	70	-	-	-	-	11.5	1

NOTE: Table shows approximate head flow for new pumps with neoprene impeller in U.S. Gallons per minute. Capacities reduced approximately 10% with nitrile impellers.

## SERVICE INSTRUCTIONS

### Disassembly

1. Remove end cover nuts, bottom bolt, end cover and O-Ring from body.
2. Remove impeller.
3. Remove top and side bolts, body, wearplate, wearplate gasket and seal housing.
4. SEAL REMOVAL – Standard Seal
  - a. Seal will be removed when the seal housing is removed.
  - b. Seal seat and gasket will remain in the seal housing. All other parts drop free.
  - c. Remove seal seat and gasket from seal housing.
5. Loosen cam screw and remove cam from body. (Clean off Permatex.\*)
6. Remove slinger from shaft.
7. Using extreme care not to mar the pedestal bore, insert screwdriver between O.D. of inner bearing seal and pedestal bore and pry out the seal.
8. Repeat step #7 for removal of outboard seal.
9. Remove inboard and outboard retaining rings from pedestal.
10. Tap impeller drive end of shaft lightly with a soft nosed mallet and remove shaft and bearing assembly.
11. Supporting outboard bearing inner race, press shaft through bearing from pump drive end. Supporting inboard bearing inner race, press shaft through bearing from impeller drive end.

Note: Inspect all parts for wear or damage and replace if necessary.

### Assembly

1. Press inboard bearing onto shaft, supporting inner race until seated against shaft shoulder.
2. Press outboard bearing onto shaft, supporting inner race of inboard bearing and pressing on inner race of outboard bearing until seated against shaft shoulder.
3. Install inboard retaining ring in pedestal retaining ring groove.
4. Lubricate O.D. of bearings with a light film of oil and install shaft and bearing assembly (splined end first) from outboard end of pedestal. Use care to keep bearings aligned with bore.
5. Install outboard retaining ring in pedestal retaining ring groove.
6. Pack area between seal and bearing (inboard and outboard) with water pump grease. Lubricated lip and O.D. of seal with water pump grease and press seals into pedestal. Seal lip faces away from the bearing.
7. Install slinger on shaft, leaving approximately 1/16" between inboard bearing seal and slinger.
8. Permatex screw threads and top side of cam. Install in body with cam screw.
9. Install O-Ring in pump body O-Ring groove, on the end that does not have tapped holes in the flange.
10. For models with STANDARD SEAL:
  - a. Assembly seal housing, wearplate gasket, wearplate and body with one bolt in the top hole from the drive end and one in the bottom from the pump end. Be sure that the tapped holes in the body are at the end cover flange.
  - b. Install the two remaining bolts from the drive end and cross tighten these two bolts.
  - c. Remove the bolt from the bottom hole.
  - d. Install dry seal seat and seal seat gasket assembly in seal housing. Lubricate gasket O.D. with water to ease assembly.
  - e. Position ferrule and carbon ring assembly on shaft with carbon face against the seal seat.
  - f. Install marcel washer on shaft.
11. Lubricate impeller bore with water or petroleum jelly and install impeller with a rotary motion until the splines engage, then push into the bore.
12. Install O-Ring in body O-Ring groove.
13. Install end cover and secure with nuts on top and side bolts.
14. Install bottom bolt from end cover and secure with nut.

**ITT JABSCO**

A Unit of ITT Corporation

1485 Dale Way, P.O. Box 2158  
Costa Mesa, California 92628-2158  
Telephone: (714) 545-8251