



Model 4720-Series

SELF-PRIMING PUMP FEATURES

- Body:** Type 316 Stainless Steel
Impeller: Neoprene or Nitrile
Seal: Lip Type
Shaft: Steel Motor Shaft with special Stainless Steel Sleeve
Ports: 1/2" NPT Internal
Motor: 1/3 HP, 115/230 Vac, 60 Hz, Single Phase, T.E.F.C., 1725 RPM, Continuous Duty, 56-Frame, Capacitor start with automatic reset thermal overload protector; 6 foot cord with three prong plug.
Weight: 35 lb (15.9 kg)



Model 4720-Series

	WARNING Explosion hazard. Do not use where flammable vapors are present. Do not pump solvents, thinners or gasoline. To do so can cause an explosion which can result in injury or death.
------------------------------------------------------------------------------------	--------------------------------------------------------------------------------------------------------------------------------------------------------------------------------------------------

VARIATIONS AVAILABLE

MODEL NO.	DESCRIPTION
4720-0001	NEOPRENE IMPELLER
4720-0003	NITRILE IMPELLER

APPLICATIONS

CHEMICAL - Industrial Motor Pump Unit Circulating, Transferring and Filtering of Chemicals, Plating Solutions, Pharmaceuticals, Cosmetics and Farm Chemicals, Emptying and Filling Carboys, Vats, Tanks, Barrels or Entire Systems.

OPERATING INSTRUCTIONS

INSTALLATION - Pump may be installed in any position. Rotation of motor determines the location of the pump intake. The motor is normally wired for clockwise rotation when looking at pump cover, with inlet port on the right.

SELF-PRIMING - Vertical, dry suction lift of 10'. Pump will produce suction lift up to 22' when wet. BE SURE SUCTION LINES ARE AIRTIGHT or pump will not self-prime.

DISCHARGE - When transferring liquids further than 25', use 1" ID discharge line.

RUNNING DRY - Unit depends on liquid pumped for lubrication. DO NOT RUN DRY FOR MORE THAN 30

SECONDS. Lack of liquid will damage the impeller and seal.

PRESSURES - For continuous operation, pressure should not exceed 20 psi (1.4 kg/cm²).

TEMPERATURE - Neoprene Impeller 45° to 180° F (8° - 82° C), Nitrile Impeller 50° to 180° F (10° to 82° C).

SPARE PARTS - A Jabsco Service Kit should be kept on hand to maintain all but the most badly worn pumps.

NOTICE - When corrosive fluids are handled, pump life will be prolonged if pump is flushed with water after each use or after each work day. For further information, consult Jabsco Chemical Resistance Table, which is available upon request.

SERVICE INSTRUCTIONS

DISASSEMBLY

TO REPLACE IMPELLER

1. Remove end cover cap screws, end cover, gasket and wearplate.
2. Grasp impeller hub with water pump pliers and withdraw impeller from body. Check seal and internal parts, for wear. Replace worn parts if necessary.

TO REPLACE SEAL ASSEMBLY

3. Loosen adaptor clamp nut and remove pump head from motor Use a screwdriver to spread the clamp slightly to facilitate removal.
4. See above Step #1.
5. Remove body, gasket and wearplate from adaptor. Push impeller from body bore.
6. Remove seal liner and seal by pressing from motor end of adaptor.
7. Remove seal from liner. Check all parts for wear. Replace if questionable.

ASSEMBLY

TO REPLACE IMPELLER

1. Coat body bore and end of impeller extended insert with a light film of water pump grease. Align detent in impeller extended insert with keyway in shaft. Depress the two impeller blades which fit under the cam, and carefully push the impeller into the body bore. Use a screwdriver in the drain slot area to push the neoprene slinger up onto the end of the extended impeller. Rotate the impeller in a clockwise direction to assure the impeller blades are in the correct position for easy starting.
2. Replace wearplate, gasket, end cover and secure with end cover cap screws.

TO REPLACE SEAL ASSEMBLY

3. Install seal liner in bore of adaptor, aligning bolt holes carefully.
4. Dip seal in water for lubrication and push into seal liner bore with lip facing outwards. Wipe a thin film of grease on lip of seal.
5. Install wearplate against liner, install gasket, align bolt holes.
6. Push the impeller into the body and rotate the impeller in a clockwise direction to align blades for correct direction of rotation. Place the body impeller assembly over the gasket and wearplate, and carefully insert the impeller extended insert through the seal.
7. Install the four capscrews through the adaptor flange and screw into threaded holes in body flange. Tighten bolts evenly and securely.

8. Repeat Step #2.
9. Align the tab in the slinger bore with the keyway in the shaft and push the slinger part way onto the shaft.
10. Align the detent in the impeller extended insert with the keyway in the shaft and push the pump head onto the motor hub, firmly against the motor. Tighten the adaptor clamp nut just enough to prevent the pump head from turning on the motor hub. If too tight, motor bearing will seize the shaft and become damaged during operation. Attach short lengths of hose to suction and discharge ports and place both hose ends in a bucket of water, before plugging motor in, to check operation.

EXPLODED VIEW

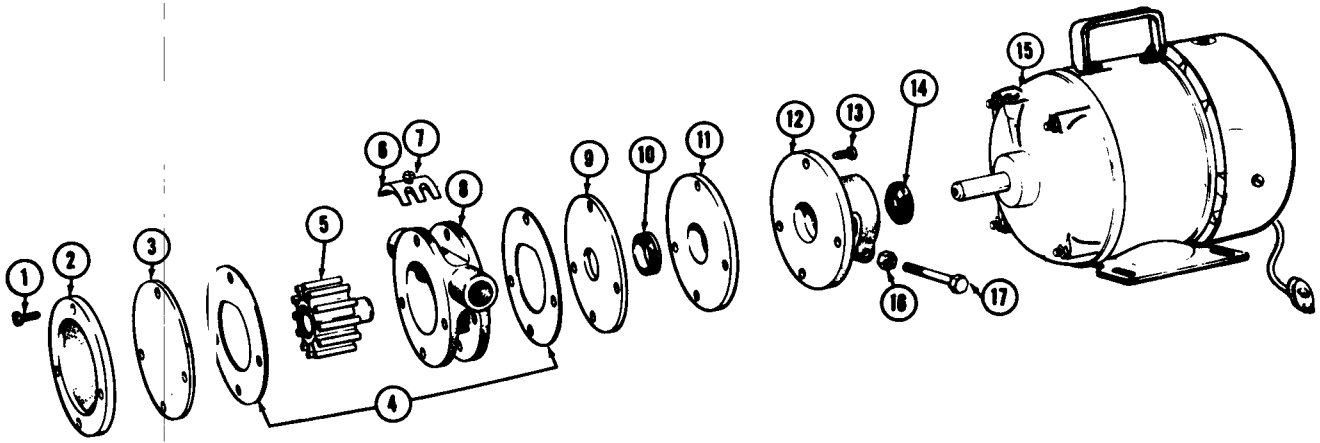

PARTS LIST

Key	Description	Qty. Req.	Part Number
1	Screw (End Cover)	4	91106-0070
2	End Cover	1	4919-0000
3	Wearplate (Body to End Cover)	1	4918-0000
4	*Gasket	2	2876-0000
5	*Impeller (Neoprene)	1	6174-0001
	(Nitrile)	-	6174-0003
6	Cam	1	2880-0000
7	Screw (Cam)	1	91023-0010
8	Body	1	2873-0000
9	Wearplate (Body to Adaptor)	1	4357-0000
10	*Seal	1	92700-0520
11	Liner	1	4354-0000
12	Adaptor	1	4355-0000
13	Screw (Adaptor)	4	91106-0070
14	Slinger	1	6398-0000
15	Motor (includes Handle, Cord & Plug)	1	18735-0000
16	Nut (Adaptor)	1	91105-0030
17	Bolt (Adaptor)	1	91095-0090
-	Replacement Pump Head Only (Neoprene)	-	4730-0001
-	Service Kit	-	90045-0001

* Parts Included in Service Kit

DIMENSIONAL DRAWING
Inches (Millimeters)

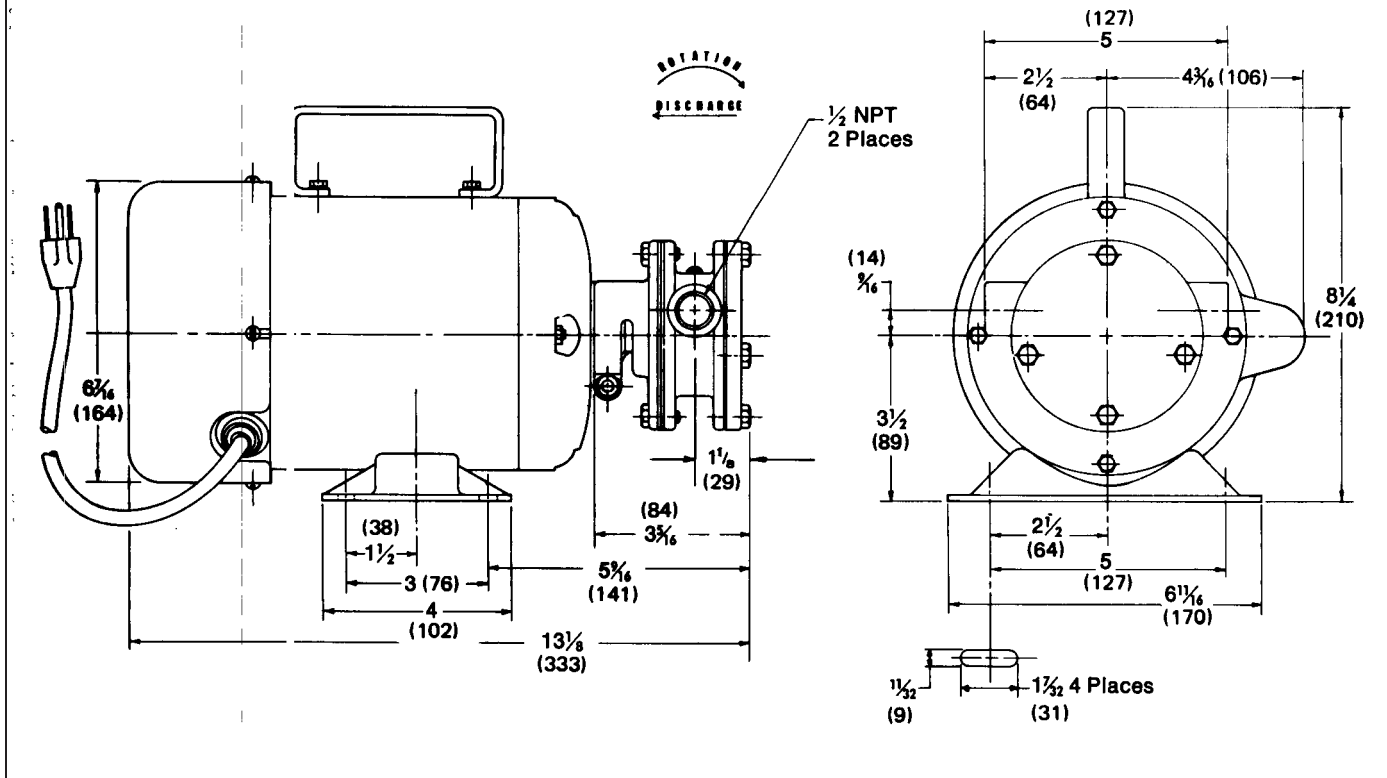

HEAD VS. FLOW TABLE

		TOTAL HEAD		CAPACITY	
				Flow at 1725 RPM	
PSI	KSI	FEET	METERS	GPM	l/MIN
4.3	0,3	10	3,0	11.0	41,6
8.7	0,6	20	6,1	10.0	37,9
17.3	1,2	40	12,2	6.7	25,4
21.6	1,5	50	15,2	5.0	18,9

Table shows approximate Head-Flow for new pump in U.S. GPM and litres per minute with Neoprene impeller.

Jabsco



THE PRODUCTS DESCRIBED HEREIN ARE SUBJECT TO THE JABSCO ONE YEAR LIMITED WARRANTY, WHICH IS AVAILABLE FOR YOUR INSPECTION UPON REQUEST.

U.S.A.
Jabsco
1485 Dale Way, P.O. Box 2158
Costa Mesa, CA 92628-2158
Tel: 714.545.8251
Fax: 949.859.1153

UNITED KINGDOM
Jabsco
Bingley Road, Hoddesdon
Hertfordshire EN11 0BU
Tel: +44 (0) 1992 450145
Fax: +44 (0) 1992 467132

CANADA
Fluid Products Canada
55 Royal Road
Guelph, Ontario N1H 1T1
Tel: (519) 821.1900
Fax: (519) 821.2569

JAPAN
NHK Jabsco Company Ltd.
3-21-10, Shin-Yokohama
Kohoku-Ku, Yokohama, 222
Tel: 045.475.8906
Fax: 045.475.8908

GERMANY
Jabsco GmbH
Oststrasse 28
22840 Norderstedt
Tel: +49-40-53 43 73 -0
Fax: +49-40-53 53 73 -11