

JABSCO®

CENTRIFUGAL PUMPS

MODELS: 45840-0000
45850-0000
45860-0000
MOTOR PUMP UNITS

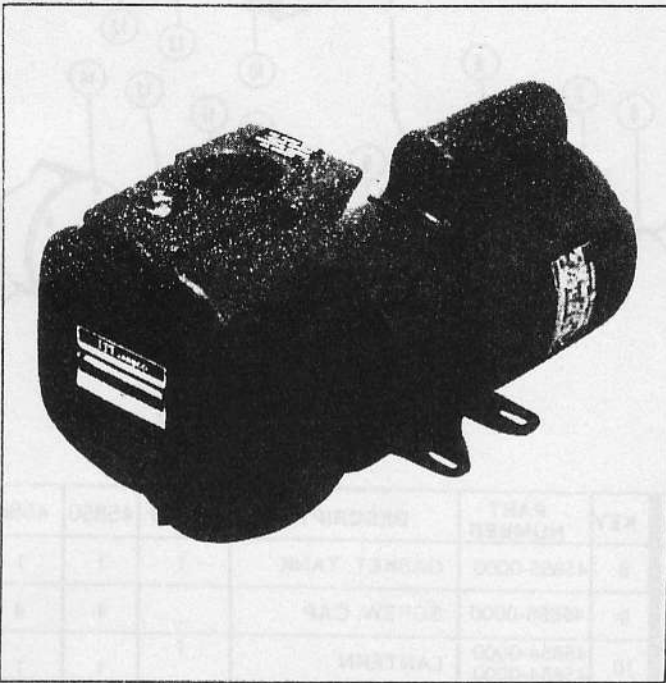

PRODUCT DATA DESIGN FEATURES

BODY — CAST IRON
IMPELLER — CAST IRON

45840-CLOSED
45850-CLOSED
45860-OPEN

SHAFT — MOTOR SHAFT — 416 S.S.
SEAL — CARBON/CERAMIC/BUNA-'N'
MECHANICAL FACE SEAL

PORTS — 2" N.P.T., SUCTION AND DISCHARGE
MOTOR — 115/230V A.C. 1 PH. 60 Hz.
3450 R.P.M., OPEN DRIP PROOF
THERMAL OVERLOAD PROTECTED
CONTINUOUS DUTY.

MODEL 45840-0000 — 1 H.P.
MODEL 45850-0000 — 1-1/2 H.P.
MODEL 45860-0000 — 2 H.P.

WEIGHT — MODEL 45840-0000 — 65 LBS. (30 Kg)
MODEL 45850-0000 — 70 LBS. (32 Kg)
MODEL 45860-0000 — 95 LBS. (43 Kg)

MODELS: 45840-0000 45850-0000 45860-0000

APPLICATION AND OPERATING INSTRUCTIONS

While cast iron is not normally considered compatible with salt water, the JABSCO cast iron self priming centrifugal is a cost effective method of handling general purpose dockside pumping requirements. As an option, pumps are available with explosion proof motors, which should be used for petroleum product transfer and below deck bilge pumping. To provide mobility for your motor pump unit, the model 45838-0000, two wheel mounting cart is available. It is recommended that a ground fault interrupter be used with all dockside fixed or mobile installations.

For satisfactory operation and safety do not subject pump to pressures which exceed one and one-half times the pump shut-off pressure (zero flow) as indicated by pump's performance curve.

PERFORMANCE CURVES

The Performance curves were taken from actual tests of standard production pumps, and reflect an average performance of the pumps indicated.

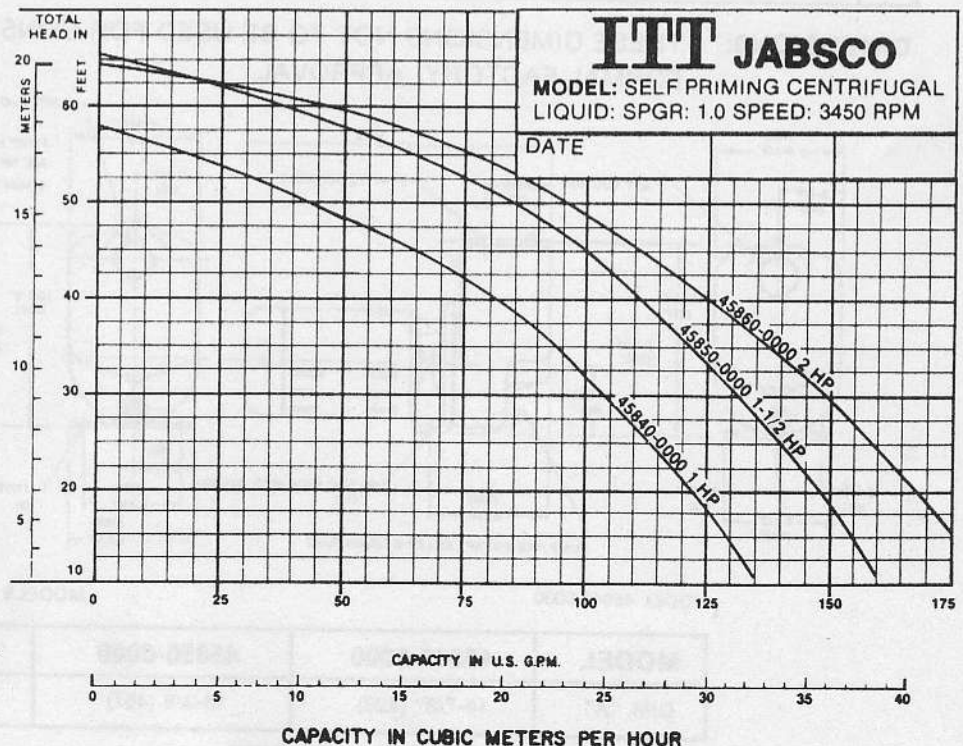

PARTS LIST

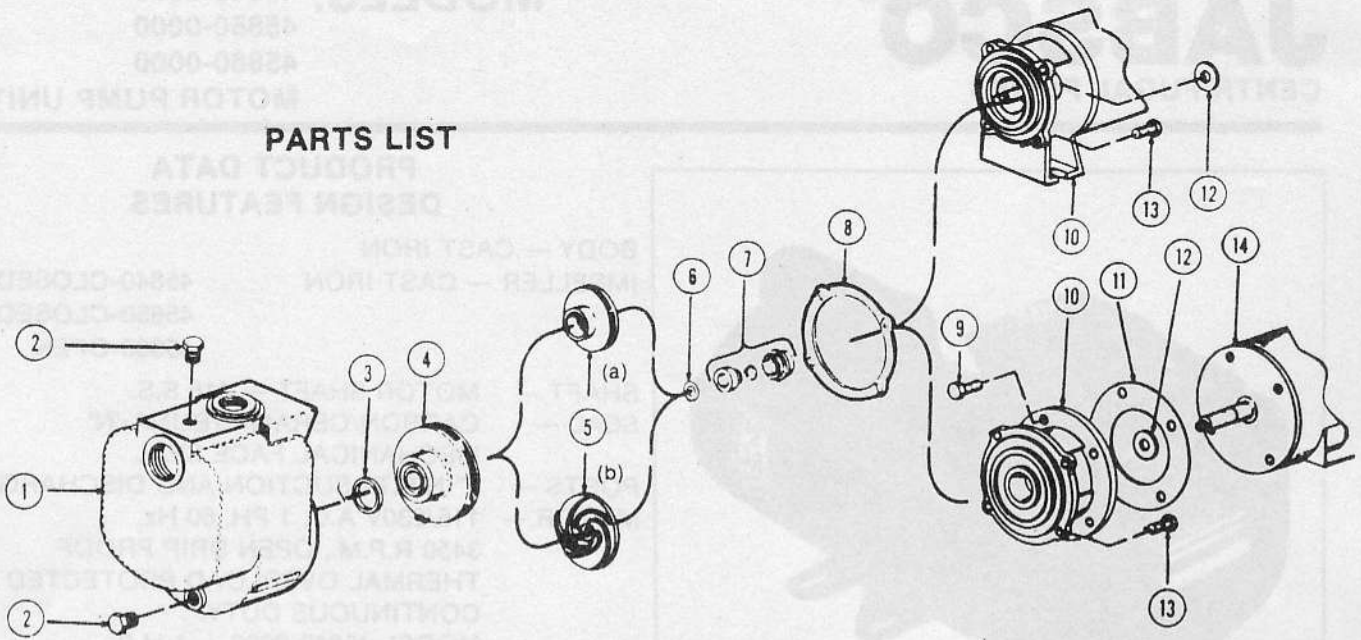

KEY	PART NUMBER	DESCRIPTION	45840	45850	45860	KEY	PART NUMBER	DESCRIPTION	45840	45850	45860
1	45843-0000	TANK	1	1	1	8	45855-0000	GASKET, TANK	1	1	1
2	45844-0000	PLUG FILLER DRAIN	1	1	1	9	45856-0000	SCREW, CAP	—	4	4
3	45845-0000 45865-0000	GASKET, DIFFUSER	1	1	1	10	45854-0000 45864-0000	LANTERN	1	1	1
4	45846-0000 45866-0000	DIFFUSER	1	1	1	11	45853-0000	SHIM, LANTERN	—	1	1
5	45847-0000	IMPELLER (a)	1			12	45858-0000	SLINGER	1	1	1
	45857-0000	IMPELLER (a)		1		13	45859-0000	SCREW, CAP	4	4	4
	45867-0000	IMPELLER (b)			1	14	45863-0000	MOTOR, 1 HP	1		
6	45848-0000	SHIM, IMPELLER	1	1	1		45868-0000	MOTOR 1½ HP		1	
7	45849-0000	SEAL ASSEMBLY	1	1	1		45869-0000	MOTOR 2 HP			1

DIMENSIONS: THESE DIMENSIONS NOT TO BE USED FOR CONSTRUCTION PURPOSES WITHOUT FORMAL FACTORY APPROVAL.

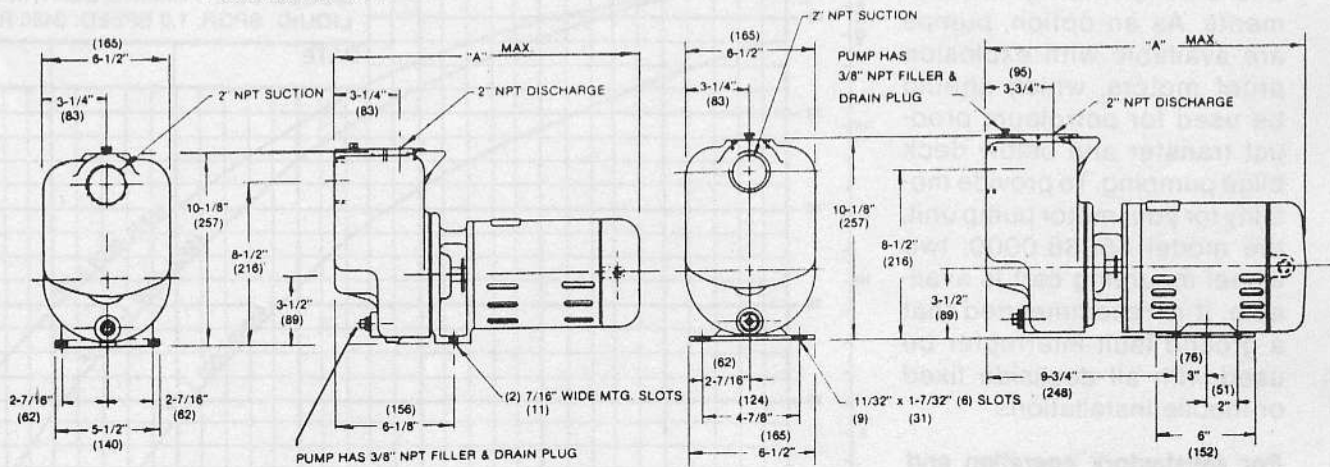

MODEL 45840-0000

MODELS 45850-0000, 45860-0000

MODEL	45840-0000	45850-0000	45860-0000
DIM. "A"	16-7/8" (429)	18-3/8 (467)	18-7/8 (479)

() MILLIMETER EQUIVALENTS

Should the fluid temperature rise more than 50°F., expansion joints must be installed on both the suction and discharge ports to relieve any stress on the pump casing.

All electrical wiring of the pump installation should be done by a licensed electrician who will observe all national and local electrical codes.

No modifications, additions or deletions should be made to the pump, without prior approval of the factory.

Prime movers powering the pumps may operate at high temperatures and to avoid burns — keep hands off the motor shell.

After servicing a pump, always install the safety devices as originally found prior to disassembly.

In systems where shock wave pressures may be generated, protective devices (check valve/gate valve, etc.) must be installed on discharge line to prevent shock wave pressures from entering casing. A discharge check valve is required when operating against high static heads.

Drain casing completely when servicing pump handling volatile or harmful liquids.

The described pumps are available with explosion-proof motors for use in hazardous locations. The standard explosion-proof motor supplied is Class 1, Group D, with a temperature rating of T3B. *This rating is not satisfactory for all Group D atmospheres.* Explosion-proof motors with lower temperature ratings are available at extra cost.

It is the responsibility of the user to properly identify the type of hazardous atmosphere at his location and to specify the Class, Group and Frame Temperature limit of the equipment to meet his application needs.

The performance of ITT Jabsco pumps is based upon water conditions involving clear, cool water with suction characteristics shown on the performance curve. If used to pump other liquids, the pump's performance may differ from the rated performance based upon the different specific gravity, temperature, viscosity, etc. of the other liquid from the above water characteristics. However, a pump may not be safe for pumping all types of liquids, such as those that are toxic, volatile, of a chemical substance, or liquids at extreme temperatures or pressures. Please consult local codes and general references, such as the Hydraulic Institute, as to the type of pump which may be safe for such application. It is impossible to anticipate all application to which an ITT Jabsco pump may be used and if you intend to use the pump for non-water application, you should consult ITT Jabsco as to whether such application may be proper or safe under the circumstances.

Should these pumps be selected for pumping harmful or corrosive liquids, make sure necessary safety precautions are taken to protect the operator or any nearby equipment before the system is started up.

LOCATION

By placing your Jabsco pump on a firm, level foundation, you reduce harmful vibrations and unnecessary

noises. Best pump operation is obtained by locating the pump as close as possible to the liquid being handled, keeping in mind a pump can push liquid more effectively than it can pull or draw liquid. Provide the necessary space around the pump for future inspection and servicing of the unit. These Jabsco pumps are self-priming and may be located above the source of liquid supply.

CONNECTIONS

Connections at the easily accessible suction and discharge ports can be made with either hose or pipe. The use of strongly reinforced suction hose will prevent collapsing of the hose during operation. New hose washers should be used at the couplings to prevent trouble-causing leaks. All hose or pipe should be independently supported to eliminate excessive strain on the pump.

STRAINER ADVISABLE

Basket line strainers are recommended and should be attached to the suction line to prevent foreign debris from clogging the impeller or diffuser.

PIPING

All piping, especially the suction line, should be as short as possible, with the fewest elbows, to reduce friction loss.

Installations requiring long pipe lines or handling hot liquids require provisions for relieving expansion and contraction of the pipe to eliminate severe pipe strains on the pump. The length of the line, the number of elbows, the fittings and the quantity of liquid to be pumped should be considered before selecting the size of pipe to be used. Piping should be the same size as the suction connection. Use a friction loss table to convert elbows and fittings to straight pipe losses when determining the exact friction loss and the pipe size required.

Desirable and recommended are the use of eccentric reducers, taper reducers, long-sweep elbows, and continuous rise piping. Gate and check valves may be used on the discharge side. The check valve is placed between the pump and gate valve. It is used to prevent shock pressures or water hammer from damaging the pump, or, reversed rotation if no foot valve is used.

PRIMING

The first time the pump is used the pump tank must be filled with liquid before starting. Fill the pump through the pipe plug located on top of the tank.

Your pump has been designed to prime itself within a few minutes. High suction lifts require additional time and reduce the performance of the pump. Should you have difficulty, refer to the "Trouble Guide".

ITT Jabsco pumps prime and reprime themselves providing the tank is filled with liquid. Should you lose this liquid from the tank accidentally or by draining purposely, it will be necessary to refill it with liquid before starting. Damage is likely to result if pump is operated dry. Open any suction and discharge valves during the priming cycle.

ROTATION

Your pump is specifically designed to rotate in a counter-clockwise direction, when viewing the motor from the pump end.

LUBRICATION

Follow the motor manufacturer's instructions carefully. Most electric motors use sealed ball bearings. Check your motor nameplates for detailed lubrication information.

The liquid being pumped cools and lubricates the seal. Running the pump dry will damage the seal. Always keep liquid in the pump tank, then no further lubrication of the pump is necessary.

WARNING!

All electrical work *must* be done by a licensed electrician. Before working on motors be certain that the electrical power is off at the main junction box. Disconnect the fuse or circuit breaker and have the main switch tagged "Do Not Energize This Switch, Personnel Working on Equipment."

CAUTION!

Some motors are equipped with built-in thermal overloads to shut off the motor in the event the temperature becomes excessive (as a result of mechanical or electrical problems such as low voltage, poor ventilation, overloaded lines, etc.). These motors *will restart automatically* as the motor cools down. *For safety sake*, do not work on any motor without first shutting off the electricity at the source as outlined above in the "Warning".

TROUBLE GUIDE

NOTE: Should pump be handling a harmful fluid, make sure necessary safety precautions are undertaken before implementing any recommended action in the accompanying Trouble Guide

(The following are some common causes of problems that may arise.)

SYMPTOMS	PROBABLE CAUSE	RECOMMENDED ACTION
Will not prime.	1. No liquid. 2. Air leak. 3. Blocked line. 4. Worn seal.	Fill tank with liquid. Tighten all joints or remake using new compound. Clean strainer or suction line. Install new seal.
Suddenly stops pumping.	Clogged strainer or impeller.	Clean Debris.
	Missing or broken impeller key.	Replace.
Slowly stops pumping.	Clogged impeller, diffuser or lines.	Clean debris and use strainer.
Leakage around the pump shaft while operating.	Worn seal.	Replace seal.
Will not hold prime.	Worn seal.	Replace seal.
Performance poor.	Worn impeller or seal.	Replace with new impeller or seal.
	Suction lift too high.	Relocate pump closer to supply.
Low flow or pressure.	Motor not up to speed: 1. Low voltage. 2. Worn motor bearings. 3. Overloaded.	Larger lead wires. Replace or rebuild. Change liquid, pump or motor.
Noisy operation.	1. Worn motor bearings. 2. Low discharge head. 3. Debris lodged in impeller.	Replace. Throttle discharge. Remove cover and clean out.

ITT JABSCO

MARC Division

International Telephone and Telegraph Corporation

1485 Dale Way, Costa Mesa, California 92626

Telephone: (714) 545-8251