

JABSCO® SEACOCKS

MODEL 45560-Series

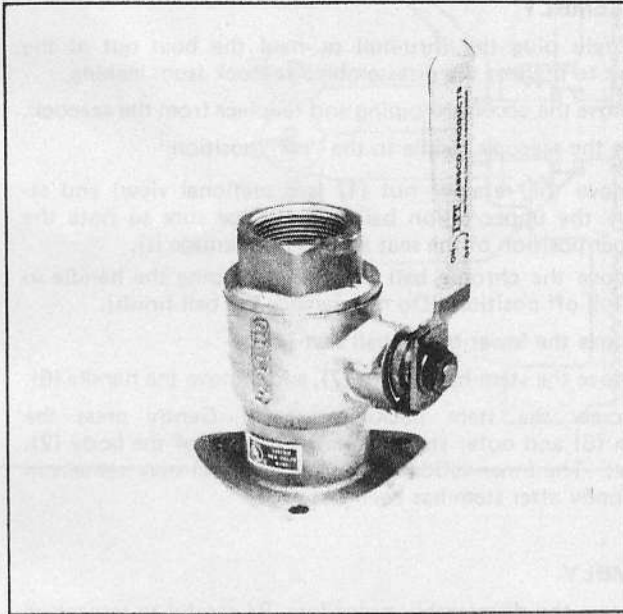

FEATURES

- Bronze and stainless steel construction
- Teflon* seats and seals for low operating torque
- Compact and lightweight
- All valves vacuum and pressure tested
- Balls are hard chrome plated bronze
- No maintenance necessary
- UL listed Sea Valve

STANDARD MODELS

Model Number	Size	Shipping Wt/Piece	PCS/Carton
45560-0075	3/4"	2.32 lb (1,1 kg)	2
45560-0100	1"	3.80 lb (1,7 kg)	2
45560-0125	1-1/4"	5.75 lb (2,6 kg)	2
45560-0150	1-1/2"	6.30 lb (2,9 kg)	2
45560-0200	2"	10.20 lb (4,6 kg)	2
45560-0250	2-1/2"	18.20 lb (8,3 kg)	2

MODEL 45560-Series

APPLICATIONS AND OPERATION:

Jabco seacocks are among the highest quality and most reliable sea valves available today. Any hull penetration in a location that is below the water line at anytime must have a seacock. Penetrations such as engine coolant water intakes, toilet intakes and discharges, and other utility salt water intakes all must be fitted with a seacock.

The seacock is operated by simply turning the handle 1/4 turn to the positive stop. When the handle is oriented perpendicular to the seacock body, the seacock is closed. When the handle is oriented along the axis or parallel to the seacock body, the seacock is open.

Each seacock is threaded according to the model size with National Pipe Straight Threads on the flanged end in order to fit with standard thru-hull fittings. The tailpiece end of the seacock (Retainer Nut) is manufactured with National Pipe Tapered Thread to fit most standard tailpieces and pipe nipples.

INSTALLATION:

1. Select an appropriate accessible location for a thru-hull penetration and seacock. Be sure that there will be adequate room to mount and operate the seacock and any accessory plumbing necessary. (Note: The drain plug on the seacock body must be oriented to allow drainage of the ball when winter-proofing.)
2. Prepare a backing or butt block to the proper size and shape to fit the hull form where the seacock is to be mounted. The backing block or hull reinforcement should be of a compatible material, which is of sufficient thickness and size to reinforce the holed area of the hull to a strength that is at least equal to the strength of a similar hull area without a hull penetration. The shape of the block should not distort the hull or seacock flange after the seacock is securely mounted.

*Teflon is a trademark of E.I. Du Pont de Nemours and Company.

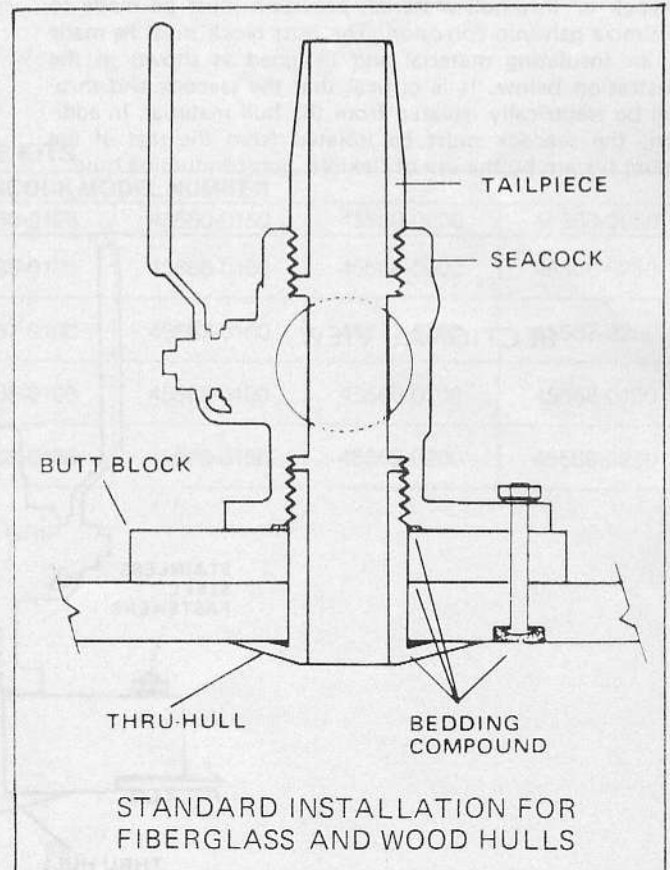

ITT JABSCO

3. Drill or cut a hole in the hull and the backing block large enough to accommodate the thru-hull fitting. Assemble the seacock and thru-hull in the proper mounted position. Mark the bolt hole (3) locations on the butt block. Remove the seacock and the thru-hull and drill the 3 bolt holes (11/32" dia.) in the butt block. Reassemble the seacock, thru-hull fitting, and butt block to the hull and mark the bolt hole locations on the hull. Remove the seacock, hull fitting, and butt block and drill 3 bolt holes (11/32" dia.) through hull. Counter bore the hull material to accommodate the mounting bolt heads. Thoroughly clean the hull and the butt block holes of shavings, burrs, etc.
4. Apply some bedding compound to the underside of the thru-hull flange, the seacock mounting flange and counter bore, the bolt holes, and between the butt block and hull material. Assemble the thru-hull fitting, seacock, and butt block, using three stainless steel (5/16" dia.) bolts. Recheck the thru-hull fitting for proper tightness. Fill counter bores for bolt heads with bedding compound.

In some installations, depending on hull material, etc., bonding the seacock assembly to the other submerged portions of the hull and hull accessories may be necessary. The bonding wire can be connected to one of the stainless steel bolts that was used to mount the seacock assembly to the hull. To prevent possible extensive hull damage, it is imperative that the installer of the seacock assembly determine whether or not the assembly should be bonded.

NOTICE: Never mount seacock with thru-hull fitting alone. It is essential to through bolt seacock to hull and butt block for maximum security.

Where the thru-hull fittings and seacocks are installed in a metal hull that is not galvanically compatible with the seacock or thru-hull material, provision must be made to minimize galvanic corrosion. The butt block must be made of an insulating material and designed as shown in the illustration below. It is critical that the seacock and thru-hull be electrically isolated from the hull material. In addition, the seacock must be isolated from the rest of the piping system by the use of flexible, non-conducting hose.

MAINTENANCE

Winterizing

1. Turn the seacock to the closed position
2. Remove the drain plug and allow the water to completely drain. If water does not completely drain, inject anti-freeze into the drain hole.
3. Replace and tighten the drain plug.

DISASSEMBLY

1. Securely plug the thru-hull or haul the boat out of the water to prevent the disassembled seacock from leaking.
2. Remove the accessory piping and tailpiece from the seacock.
3. Turn the seacock handle to the "off" position.
4. Remove the retainer nut (1) (see sectional view) and remove the upper teflon ball seat (3) (be sure to note the proper position of the seat and do not damage it).
5. Remove the chrome ball (5), while keeping the handle in the full off position. (Do not damage the ball finish).
6. Remove the lower teflon ball seat (4).
7. Remove the stem-handle nut (7), and remove the handle (6).
8. Unscrew the stem packing nut (9). Gently press the stem (8) and outer stem packing (10) out of the body (2). Note: The inner teflon stem packing (11) may remain in the body after stem has been removed.

ASSEMBLY

1. Reverse the disassembly procedure. Be careful to replace all seals and components in proper location. When installing the stem packing nut (9), tighten until compression of the inner and outer stem packing occurs. Adjust to control the operating torque to the valve handle. (Note: Do not loosen stem packing nut excessively — the valve may leak, and vibrate closed due to low operating torque).
2. When replacing the retainer nut (1) and the tailpiece, apply teflon tape or other pipe sealant to threads.

SECTIONAL VIEW

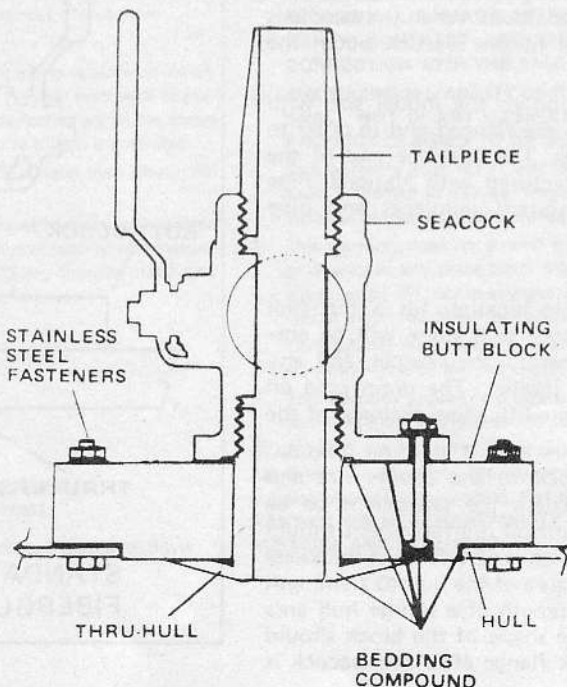

INSTALLATION WHERE HULL AND SEACOCK MATERIALS ARE NOT COMPATIBLE

SECTIONAL VIEW

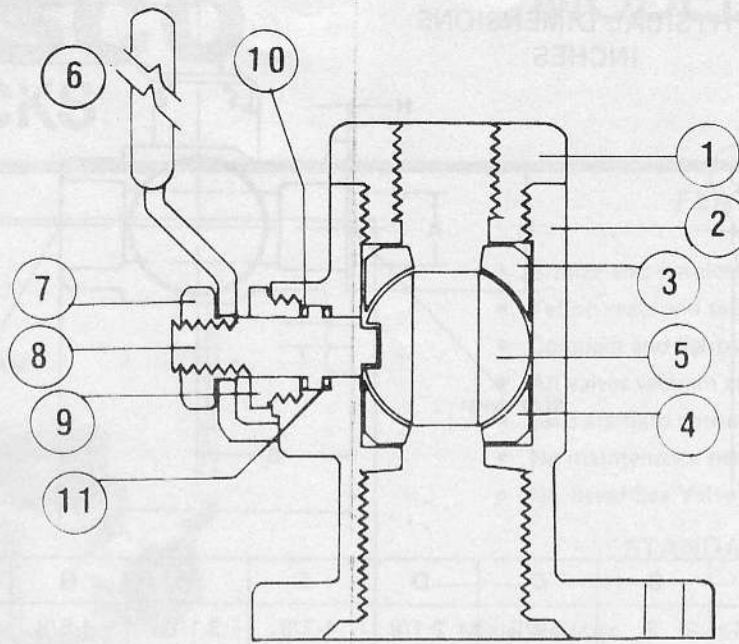

SERVICE KITS

KIT DESCRIPTION	SEACOCK MODEL NUMBER					
	45560-0075	45560-0100	45560-0125	45560-0150	45560-0200	45560-0250
BALL SEATS & STEM SEALS	45566-0075	45566-0100	45566-0125	45566-0150	45566-0200	45566-0250
HANDLE & NUT WITH GRIP	45567-0075	45567-0100	45567-0100	45567-0100	45567-0200	45567-0250
STEM & PACKING NUT	45568-0075	45568-0100	45568-0100	45568-0100	45568-0100	45568-0100
REPLACEMENT BALL	45569-0075	45569-0100	45569-0125	45569-0150	45569-0200	45569-0250

BALL SEATS AND STEM SEALS INCLUDES KEYS 3, 4, 10 & 11
 HANDLE AND NUT WITH GRIP INCLUDES KEYS 6, 7 & VINYL GRIP
 STEM AND PACKING NUT INCLUDES KEYS 8 & 9

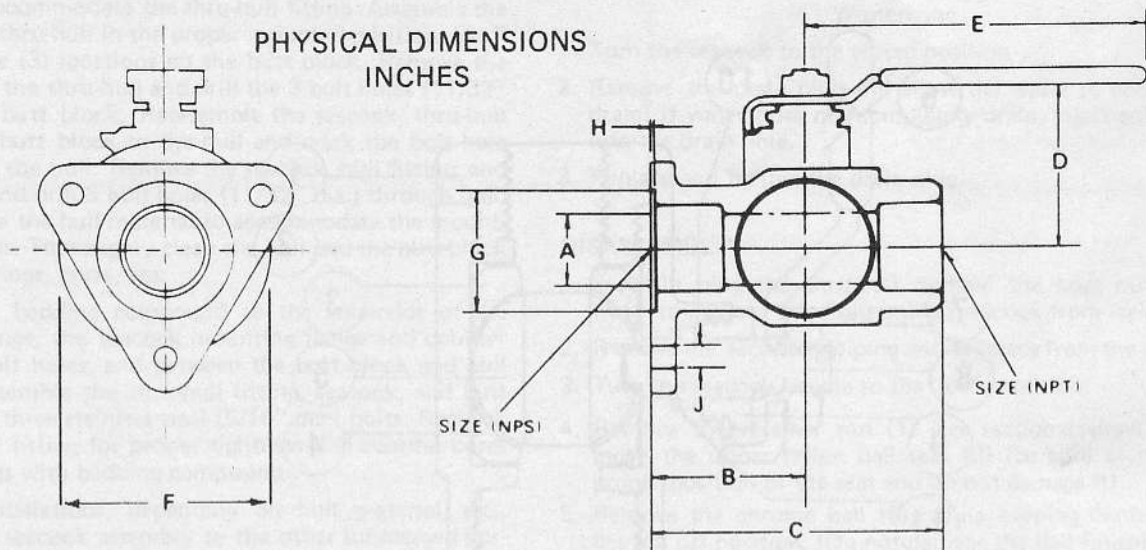

Size	Model No.	A	B	C	D	E	F	G	H	J
3/4	45560-0075	11/16	2	3-1/2	2-1/8	4-7/8	3-1/8	1-5/8	3/32	11/32
1	45560-0100	1	2-3/8	4-1/4	2-5/8	5-1/2	3-3/8	1-7/8	3/32	11/32
1-1/4	45560-0125	1-1/4	2-21/32	4-13/16	2-13/16	5-1/2	3-5/8	2-3/16	3/32	11/32
1-1/2	45560-0150	1-1/4	2-5/8	4-13/16	2-7/8	5-1/2	4-1/2	2-1/2	3/32	11/32
2	45560-0200	2	3-13/32	6-1/4	4	8	5	2-1/4	3/32	11/32
2-1/2	45560-0250	2-1/2	3-11/16	6-7/8	4	8	5-7/8	3-1/2	3/32	11/32

ONE YEAR LIMITED WARRANTY

A. WARRANTY: ITT warrants that at the time of shipment, the products manufactured by ITT and sold hereunder shall be in conformity with applicable written specifications and descriptions referred to or set forth herein, free from defects in material and workmanship, merchantable, and suitable for a particular purpose, provided such is implied by State law under the circumstances of this sale.

B. WARRANTY ADJUSTMENT:

- ITT agrees to repair or furnish a replacement for, but not to remove or install, any product or component thereof which, within one (1) year from date of purchase, shall upon test and examination by ITT prove defective within the above warranty. Receipt verifying purchase date is required to obtain adjustment.
- Buyer shall notify ITT of any defect within this warranty no later than ninety (90) days after the defect is discovered.
- No product will be accepted for return or replacement without the prior written authorization of ITT. Upon such authorization, and in accordance with instructions from ITT, the product will be returned to ITT, shipping charges prepaid by Buyer. Products returned to ITT will be addressed as follows:

ITT JABSCO PRODUCTS
1485 Dale Way
Costa Mesa, California 92626

or to such alternate locations as may be designated
on the product, its container, or this sheet.

Repair or replacement made under this warranty will be shipped prepaid to Buyer.

C. EXCLUSIONS FROM WARRANTY:

- The foregoing warranty is limited solely as set forth herein and applies only for the period designated above.
- ITT SHALL NOT BE LIABLE FOR ANY LOSS, DAMAGE, SPECIAL OR CONSEQUENTIAL DAMAGE OF ANY KIND, WHETHER BASED UPON WARRANTY, CONTRACT, NEGLIGENCE, OR STRICT LIABILITY ARISING IN CONNECTION WITH THE SALE, USE, OR REPAIR OF THE PRODUCT.**
- THE MAXIMUM LIABILITY OF ITT IN CONNECTION WITH THIS WARRANTY SHALL NOT IN ANY CASE EXCEED THE CONTRACT PRICE FOR THE PRODUCT CLAIMED TO BE DEFECTIVE OR UNSUITABLE.**
- This warranty does not extend to any product manufactured by ITT which has been subjected to misuse, neglect, accident, improper installation, or use in violation of instructions furnished by ITT.
- This warranty does not extend to or apply to any unit which has been repaired or altered at any place other than ITT's factory, or by persons not expressly approved by ITT, nor to any unit the serial number, model number, or identification of which has been removed, defaced or changed.
- Components manufactured by any supplier other than ITT shall bear only that warranty made by the manufacturer of that product.
- This warranty applies to products defined as "consumer products" by the Consumer Product Warranties Act as from time to time amended.

STANDARD WARRANTY: If the products manufactured and sold hereunder are not Consumer Products, the warranty extended to Buyer shall be as set forth in subparagraphs (a), (b), and (c). **EXCEPT THAT ALL EXPRESS OR IMPLIED WARRANTIES OR MERCHANTABILITY OR SUITABILITY FOR ANY PARTICULAR PURPOSE ARE EXCLUDED.**

ITT JABSCO

A Unit of ITT Corporation
1485 Dale Way, P.O. Box 2158
Costa Mesa, CA 92628-2158
Telephone: (714) 545-8251

Form 43000-0345 Rev. 11 86