



Model 4530-Series

SELF-PRIMING PUMPS

FEATURES

- Body:** Bronze
- Impeller:** Neoprene or Nitrile
- Shaft:** Stainless Steel
- Shaft Seal:** Packing Type
- Bearings:** Plain
- Ports:** 1/4" NPT
- Weight:** 1-1/4 lb (0,56 kg) approx.

VARIATIONS AVAILABLE

MODEL	VARIATION INCORPORATED
4530-0001	Neoprene Impeller
4530-0003	Nitrile Impeller



Model 4530-Series

APPLICATION & OPERATING INSTRUCTIONS

MARINE: Pumping bilges, Washdowns, Circulating water in bait tanks, Utility dock side pump, Engine cooling.

INDUSTRIAL: Circulating and transferring, Velocity-mixing, Pumping machine tool coolants, Return spill, Sump drainage, Chemicals, Pharmaceuticals, Soap, Liquors, Inks, Dyes, Alcohol, Various acids, Tanning liquors, Glycerine, Brine, etc.

FARMING: Pumping water for stock, Pumping water from shallow wells and cisterns, Pumping liquid ballast into tractor tires.

PLUMBING AND HOME EMERGENCY USE: Pumping out flooded basements, Cesspools, Sumps, Water heaters and water closets, Drains and sinks, Draining fishponds and pools.

1. **INSTALLATION** – Pump may be mounted in any position. Intake and discharge ports are determined by the direction of shaft rotation (refer to Dimensional Drawing). Before installing, turn the pump shaft in the direction of the operating rotation.
2. **DRIVE** – Belt or Direct with flexible coupling.
 - Belt Drive – Overtight belt load will reduce pump bearing life. Direct Drive is recommended for operating speeds above 1750 RPM.
 - Direct Drive – Clearance should be left between drive shaft and pump shaft when installing coupling. Always mount and align pump and drive shaft before tightening the coupling set screw.
3. **SPEEDS** – 100 RPM to the maximum shown in the Head Capacity Table. Consult the factory for operation at speeds above those shown. For longer pump life, operate at lowest possible speeds.
4. **SELF-PRIMING** – Primes at low or high speeds. For vertical dry suction lift of 10 feet (3 m) a minimum of 800 RPM is required. Pump will produce suction lift up to 22 feet (6,7 m) when wetted. **BE SURE SUCTION LINES ARE AIRTIGHT OR PUMP WILL NOT SELF-PRIME.**
5. **RUNNING DRY** – Unit depends on liquid pumped for lubrication. **DO NOT RUN DRY** for more than 30 seconds. Lack of liquid will damage the impeller.
6. **NOTICE** – If pumping light fraction petroleum derivatives, solvents, thinners, highly concentrated or organic acids, consult JABSCO Chemical Resistance Table (which is available upon request from ITT Jabsco) for proper body materials and impeller compounds. If corrosive fluids are handled, pump life will be prolonged if pump is flushed with water after each use or after each work day.



Injury hazard. Exposed pulleys and belts can cause injury. Install shield around pulleys and belts. Stay clear while machinery is operating.

OPERATING INSTRUCTIONS (Cont.)

7. PRESSURES – Consult Head Capacity Table for recommended maximum for continuous operation. If pressures exceed those shown, consult the factory.
8. TEMPERATURES – Neoprene impellers are suitable for service at 45° to 180° F (7° to 82° C). Nitrile: 50° to 180° F (10° to 82°C).
9. FREEZING WEATHER – Drain unit by loosening end cover. The following anti-freeze compounds can be used without any adverse effects to the neoprene impeller: Atlas "Permaguard", DuPont "Zerex" and "Telar", Dow Chemical "Dowguard" and Olin Mathison "Pyro Permanent". Most Methyl alcohol (methanol) based anti-freeze can be used.

DO NOT USE PETROLEUM BASED ANTI-FREEZE COMPOUNDS OR RUST INHIBITORS

10. GASKET – Use a standard pump part. Thicker gasket will reduce priming ability. A thinner gasket will cause the impeller to bind. Standard gasket is 0.010" thick.
11. GREASE CUP – Fill grease cup with water pump grease. Grease cup cap should be firmly tightened about every 50 hours of pump service while pump is operating. Leakage may occur through grease cup at pressures above 20 psi. If this occurs, replace grease cup with ball check grease cup.
12. SPARE PARTS – To avoid costly shut downs, keep a Jabsco Service Kit on hand.

DISASSEMBLY

1. Remove end cover screws, end cover and gasket.
2. Remove drive coupling or pulley and loosen packing nut.
3. Clean and remove burrs from flatted end of shaft.
4. Remove shaft and impeller assembly from body.
5. Remove drive screw from impeller and slide impeller off the shaft.
6. Remove cam screw and cam, clean off sealant.
7. Remove packing nut.
8. Remove packing with pick or screwdriver.
9. Inspect all parts for wear or damage and replace if necessary.

ASSEMBLY

1. Apply thin coat of sealant to cam screw threads and top and back end of cam and install in body with cam screw. (Leave loose.)
2. Position impeller on shaft and secure with drive screw.
3. Lubricate impeller bore with a light coat of water pump grease, insert shaft and impeller assembly into body with a rotary motion.
4. Dip new packing in SAE 10 or 20 weight oil and install packing.
5. Install packing nut. Do not tighten.
6. Install gasket and end cover with end cover screws. Tighten cam screw.
7. Fill grease cup full and grease cup cap 3/4 full with water pump grease. Install grease cup cap and tighten firmly.
8. Hand tighten packing nut. During operation, tighten packing nut until pump stops dripping; set locking nut. NOTE: Packing and shaft life will be improved if pump is allowed to drip about 3 drops per minute. After a few minutes of operation, re-tighten grease cup cap.

EXPLODED VIEW

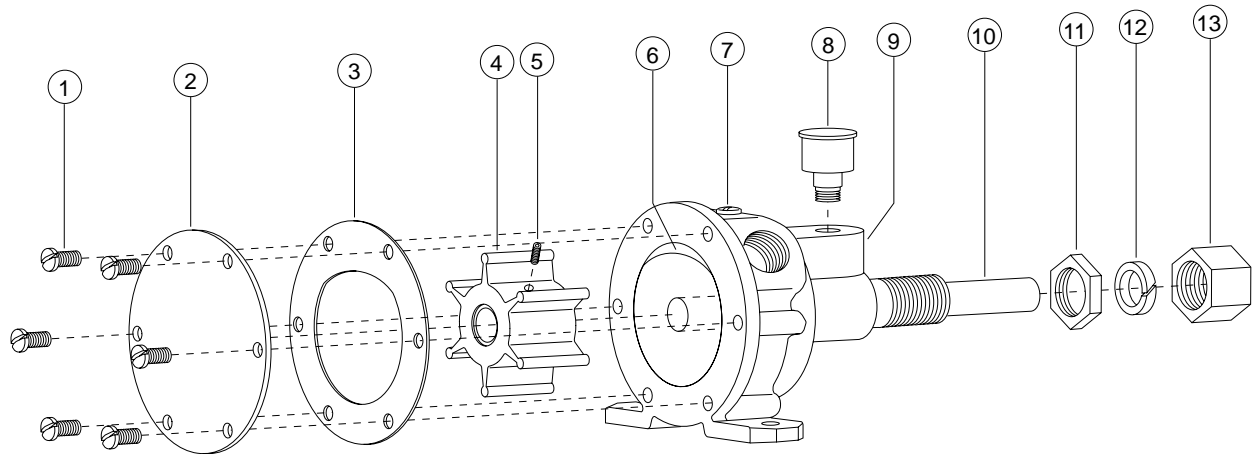

PARTS LIST

KEY	DESCRIPTION	4530-SERIES	QTY.
1	Screw (End Cover)	91002-0010	6
2	End Cover	11835-0000	1
3*	Gasket	1126-0000	1
4*	Impeller (Neoprene) Impeller (Nitrile)	4528-0001 4528-0003	1
5	Screw (Impeller)	91009-0050	
6	Cam	4538-0000	1
7	Screw (Cam)	91002-0020	1
8	Grease Cup	91501-0010	1
9	Body	4534-0000	1
10	Shaft	4537-0000	1
11	Lock Nut	5433-0000	1
12*	Packing	4539-0000	1
13	Packing Nut	4536-0000	1
Not Shown	Service Kit (Neoprene) Service Kit (Nitrile)	90001-0001 90001-0003	—

* Parts supplied in Service Kit

HEAD CAPACITY TABLE

TOTAL HEAD		500 RPM		1160 RPM		1750 RPM		2100 RPM		2450 RPM		3000 RPM		3600 RPM	
PSI (kg/sq cm)	Ft. of Water (Metre)	GPM (LPM)	HP	GPM (LPM)	HP	GPM (LPM)	HP	GPM (LPM)	HP	GPM (LPM)	HP	GPM (LPM)	HP	GPM (LPM)	HP
4.3 (0,3)	10 (3)	1.2 (4,5)	1/12	2.6 (9,8)	1/6	3.9 (14,8)	1/6	4.6 (17,7)	1/4	5.2 (19,6)	1/4	6.1 (23)	1/4	6.9 (26,1)	1/3
8.7 (0,6)	20 (6)	1.1 (4)	1/12	2.4 (9,1)	1/6	3.6 (13,6)	1/6	4.3 (16,2)	1/4	4.8 (18)	1/4	5.6 (21,1)	1/4	6.5 (24,9)	1/3
13.0 (0,9)	30 (9)	0.8 (3)	1/12	2.1 (7,9)	1/6	3.1 (11,7)	1/6	3.8 (14,4)	1/4	4.2 (15,9)	1/4	5.1 (19,2)	1/3	5.9 (22,3)	1/3
17.3 (1,2)	40 (12)			1.7 (6,4)	1/6	2.6 (9,8)	1/6	3.2 (12,1)	1/4	3.7 (13,9)	1/4	4.5 (16,9)	1/3	5.2 (19,6)	1/3
21.6 (1,5)	50 (15)							2.5 (9,3)	1/4	3.0 (11,3)	1/4	3.8 (14,4)	1/3	4.5 (16,9)	1/3

NOTE: Progressively longer life may be expected as operating pressures and speeds are reduced. Factory Application Engineering assistance suggested for operation in heavy shaded area and recommended for light shaded area. Capacitor type motor recommended. Table shows approximate Head-Flow for new pump in U.S. gallons (and litres) per minute.

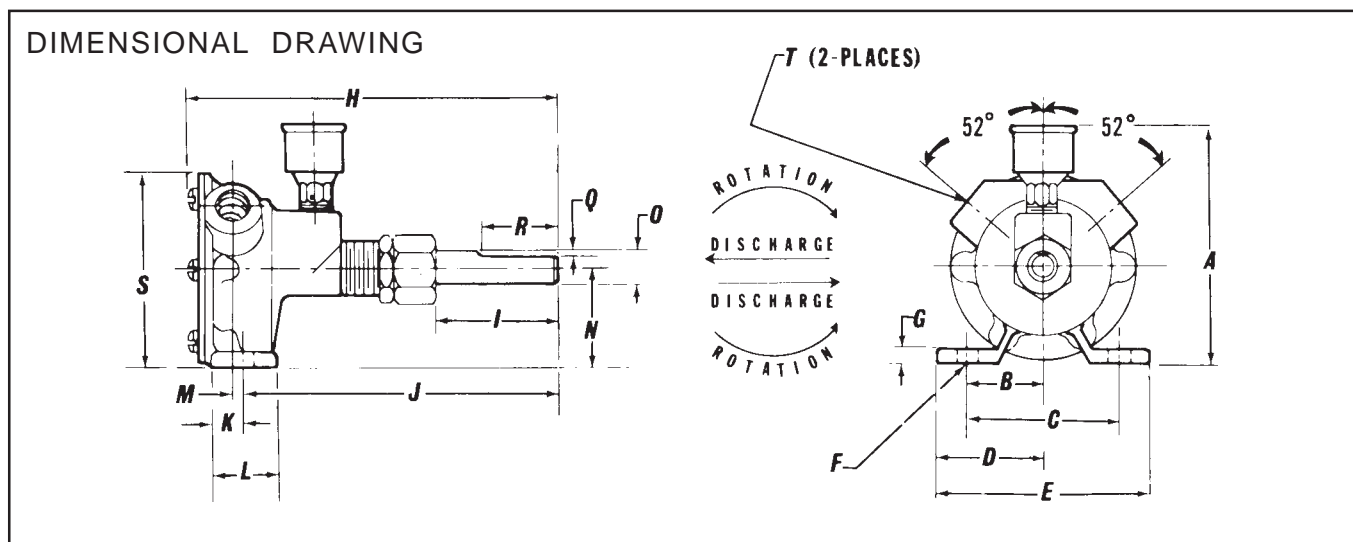

TABULATIONS FROM ABOVE DRAWING

MODEL	A	B	C	D	E	F	G	H	I	J
4530-Series	3-1/8" (79)	1-1/32" (26)	2-1/16" (52)	1-13/32" (36)	2-13/16" (71)	9/32" Dia. (7,1)	3/16" (4,8)	4-7/8" (124)	1-11/16" (43)	4-1/8" (105)
MODEL	K	L	M	N	O	Q	R	S	T	
4530-Series	7/16" (11,1)	7/8" (22,2)	1/8" (3,2)	1-1/4" (29)	0.375 0.374 Dia. (9,5)	0.024 (0,6)	1-1/8" (28)	2-1/2" (63)	1/4" NPT (6,4)	

(Millimetre equivalents)

Jabsco



THE PRODUCTS DESCRIBED HEREIN ARE SUBJECT TO THE JABSCO ONE YEAR LIMITED WARRANTY, WHICH IS AVAILABLE FOR YOUR INSPECTION UPON REQUEST.

U.S.A.
Jabsco
1485 Dale Way, P.O. Box 2158
Costa Mesa, CA 92628-2158
Tel: (714) 545-8251
Fax: (714) 957-0609

UNITED KINGDOM
Jabsco
Bingley Road, Hoddesdon
Hertfordshire EN11 0BU
Tel: +44 (0) 1992 450145
Fax: +44 (0) 1992 467132

CANADA
Fluid Products Canada
55 Royal Road
Guelph, Ontario N1H 1T1
Tel: (519) 821-1900
Fax: (519) 821-2569

JAPAN
NHK Jabsco Company Ltd.
3-21-10, Shin-Yokohama
Kohoku-Ku, Yokohama, 222
Tel: 045-4758906
Fax: 045-475-8908

GERMANY
Jabsco GmbH
Oststrasse 28
22844 Norderstedt
Tel: +49-40-53 53 73 -0
Fax: +49-40-53 53 73 -11