

PRODUCT DATA

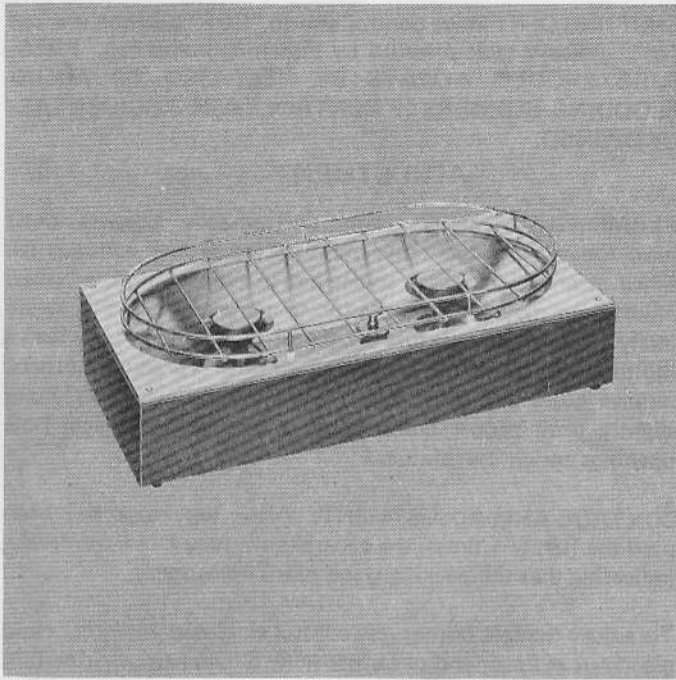

FEATURES

- Easy to use controls. Visible lever positions eliminate guesswork.
- Large efficient burners give more heat and better heat distribution.
- Self cleaning burner design - no special cleaning operation required.
- Large sturdy pump requires only a few strokes to maintain pressure.
- Large concealed tank with pressure relief valve for safety and large filler spout for easy refilling.
- Big stainless steel grate lifts out for easy cleaning; built-in guardrail holds pots on stove.
- One-piece stainless steel burner pan minimizes possibility of fuel leakage.
- Non-chip vinyl coated aluminum base for light weight.

MODEL 42870-0000

APPLICATION

This PAR Two-Burner Alcohol Marine Stove is designed for countertop operation on small boats where galley space is at a premium. Its compact length, width, and depth dimensions facilitate use in cramped areas. The PAR Model 42870-0000 is completely self-contained; no external hookups are required.

SPECIFICATIONS

Fuel Requirement:	Marine Stove Alcohol
Fuel Tank Capacity:	1 Quart (.95 liter)
Shipping Weight:	11.5 Lbs. (5.2 Kgs.)

DIMENSIONAL DRAWING

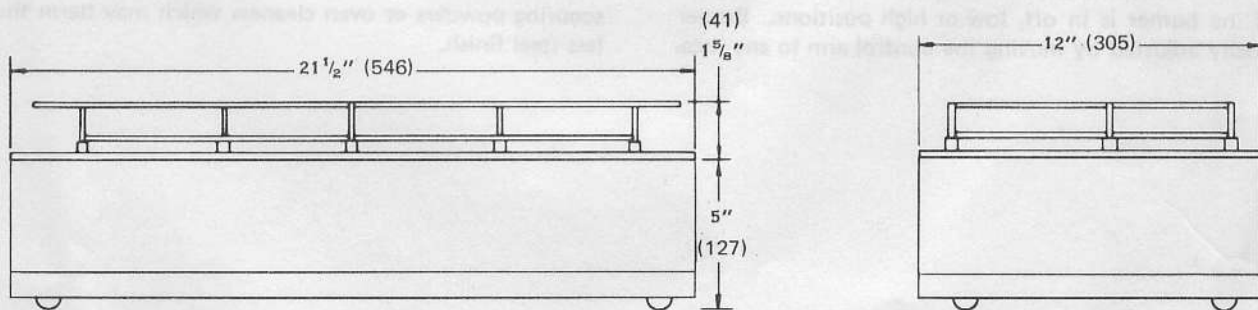

Parenthesis indicate Millimeters

OPERATION

FILLING: Lift off grate, unscrew and remove pump assembly. Fill tank with alcohol, using funnel to avoid spilling. **DO NOT OVERFILL.** Fill tank only up to mark on pump barrel with pump set into opening but not threaded into position. If using dipstick, do not exceed 2" from bottom of tank.

Replace pump and hand-tighten firmly. Don't overtighten so pump can easily be removed for refilling or to release pressure after cooking.

STARTING: Pressurize tank by pumping 7-10 strokes for a full tank. A partially filled tank will require a few additional strokes. Carefully check all tank and burner fittings under stove for fuel leaks. Tighten any leaking fittings which may have loosened in shipment.

Open burner control all the way to the "H" position for a few seconds to allow fuel to flow into priming cup around base of burner. Cup should be about one third full for starting. If there does not appear to be enough fuel in cup, reopen burner control for a second or two. **DO NOT FILL PRIMING CUP ABOVE ONE-HALF FULL.** After starting burners a few times, you will become familiar with the length of time needed to fill priming cup to proper level.

Light alcohol in priming cup with control in "off" position, marked "O" on frame. Let alcohol burn out, open burner to "H" position and light as you would a gas burner. If not sufficiently preheated, burner may flare up slightly. Should this occur, set control to very low flame and allow burner to warm up, then reset to desired heat. Burner may also be set to "off" until flame dies out and restarted following above instructions.

If flame sputters, shut off, reopen and light burner immediately.

Finally - a caution applying to all alcohol stoves. **IF BURNER SHOULD GO OUT, TURN OFF IMMEDIATELY.** If left open when not burning, fuel may be discharged into stove pan and be ignited by the other burner.

The first time the stove is lighted, the flame may be orange. This should disappear after a few minutes. See Flame Adjustment below, if orange flame persists.

The new PAR control has been designed so you can see at a glance if the burner is in off, low or high positions. Burner heat is easily adjusted by moving the control arm to any loca-

OPERATION (Continued)

tion between the L and H positions. The tank pressure will gradually decrease as fuel is consumed. If flame is too low with control in H position, tank pressure should be pumped up with a few strokes. Low tank pressure is evident, in any position of controls, when the perforated burner cups turn excessively red. Do not increase tank pressure by more than 4 strokes at a time. Do not operate with too low a flame. This may cause burner to cool and go out.

SHUTTING OFF : Move control arm to "OFF" position marked "O". Release tank pressure by loosening pump cap. **PRESSURE SHOULD ALWAYS BE RELEASED TO AVOID FLOODING BURNERS IF CONTROLS ARE ACCIDENTALLY OPENED.**

ADJUSTMENT

FLAME ADJUSTMENT: High performance burners must have the correct fuel-to-air mixture for proper combustion. Since alcohol fuel varies somewhat in composition, a burner adjustment may be needed in extreme cases, but this is unlikely. Too rich a mixture causes an orange flame; too lean a mixture will cause the burner to go out. To adjust burners, remove outer and inner caps. Turn the disc with four holes slightly until proper combustion is obtained. Smaller hole openings enrich the mixture.

CONTROL ARM ADJUSTMENT: After the stove has been used the first few times, the control arms may move too freely, indicating that the packing gland needs adjustment.

To adjust the left burner, set control to closed position. Hold gland nut at lower end of burner with $\frac{3}{4}$ " wrench. Grip burner head and turn clockwise until snug on packing gland.

To adjust the right burner, set control to open position. Hold gland nut at lower end of burner with $\frac{3}{4}$ " wrench. Grip burner head and turn clockwise until snug on packing gland.

MAINTENANCE

The PAR Model 42870-0000 Marine Alcohol Stove has been designed to provide years of trouble-free service with minimum maintenance. The exclusive PAR burner design does not require a cleaning operation as with other marine alcohol stoves. The PAR burners are self-cleaned each time they are used. Keep your PAR stove clean; however, do not use harsh scouring powders or oven cleaners which may harm the stainless steel finish.

JABSCO PRODUCTS **ITT**

Marine and Recreation Components Division
International Telephone and Telegraph Corporation
1485 Dale Way, Costa Mesa, California 92626

Telephone: (714) 545-8251