

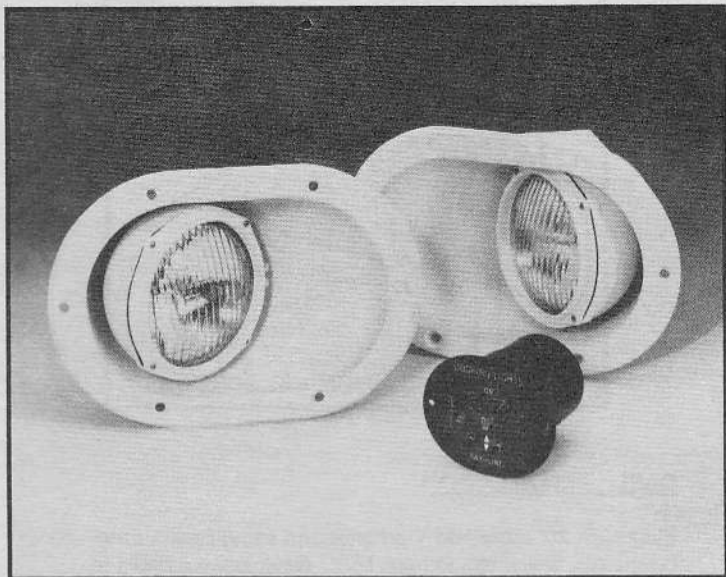

MODEL 42440-SERIES



REMOTE CONTROL DOCKING LIGHTS

FEATURES

- COMPLETELY ADJUSTABLE
- INSTALLS IN MOST HULL TYPES
- REMOTE CONTROL AND 20 FT CABLE INCLUDED
- CONSTRUCTED OF HEAVY DUTY CORROSION PROOF PLASTIC
- SEALED BEAM LAMPS
- RETROFITS MORSE TYPE "R" DOCKING LIGHT

MODEL 42440-SERIES

SPECIFICATIONS (PER LIGHT)

- VOLTAGE: 12 Vdc
- AMPERAGE: 7.5 each
- BEAM SPREAD: 40° HORIZONTAL
7° VERTICAL
- POWER RATING: 100 WATTS

Ray-Line's remote control adjustable docking lights are ideal for run-abouts and cruisers who enjoy night time boating.

These docking lights are flush mounting units, designed to become an integral part of the hull for general illumination below the deckline.

Ray-Line RC docking lights make night time boating safer than ever before.

RV'ers - Ray-Line's remote control docking lights are also ideal for today's luxury motor homes. Adjustable beam illuminates the right area for those tough parking situations. Easy to install - neat, tight fit blends with contour of vehicle.

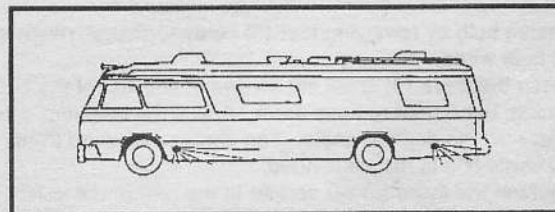
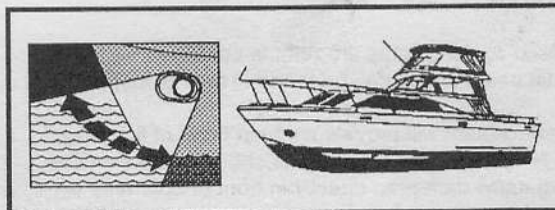

MODEL NO.	VOLTS DC	AMPS	WEIGHT lb (kg)	STANDARD Carton
42440-0000	12	7.5 (each)	9 (4.1)	1 pair
42440-0024	24	4.0 (each)	9 (4.1)	1 pair

INSTALLATION INSTRUCTIONS

LIGHT MOUNTING

Determine location on boat hull, back from the bow, where lights are to be mounted. NOTE: Do not allow boat registration numbers to influence location of lights. The numbers can be relocated at any convenient location.

1. Tape the template horizontally on hull at desired location.
2. Check inside hull for obstructions or anything that might be damaged by cutting hole.
3. Cut hole per template.
NOTE: DO NOT USE LIGHT AS DRILL JIG, AS DRILL MAY DAMAGE LIGHT.
4. Apply sealing compound to light flange and mount light. Tighten screws by giving each a few turns to pull flange evenly to hull. Compound should squeeze out all around the flange. Do not overtighten screws - wipe off excess compound.

CONTROL MOUNTING

Select a location near the helm which will allow for convenient operation of control. Unit may be mounted on vertical, horizontal or inclined panel.

1. Cut 2-5/8" (67 mm) diameter hole in flat surface where control is to be mounted.
2. Route 16 gauge (minimum) power leads from voltage source to control. Crimp terminals (supplied) onto power leads. NOTE: Larger terminal is crimped to positive lead - smaller terminal to negative lead.
3. Insert Y-adaptor cable and power leads thru back of hole and plug into control.
4. Use sealant to waterproof control mounting.
5. Secure control with mounting screws provided.

CIRCUIT PROTECTION

Two (2) automotive type fuses are located on control. Each (10 amp) fuse protects one docking light.

HORIZONTAL BEAM ADJUSTMENT

The Jabsco docking lights are remote controlled vertically. Horizontal beam adjust can be made at time of installation.

Proper adjustment will provide an even band of light dead ahead. Note: Lights beam patterns should come together or have a small dark area directly in front of boat (see diagram).

1. Remove bulb by removing four (4) screws, gasket, retainer and bulb wires.
2. Loosen the three (3) small set screws in the rear of the bulb housing, but do not remove them. Adjust the housing horizontally to desired angle. Ten degrees outward from bow centerline is recommended.
3. Retighten the three (3) set screws in the rear of the bulb housing (see diagram) and replace bulb, gasket, retainer, bulb wires and four (4) screws.
NOTE: Depending on the angle set only two (2) of the adjusting screws may contact the housing.

NOTICE: When using lights, don't shine them at oncoming boats. Turn off one light, if necessary, and use the other for illumination.

CAUTION: Be careful not to cross thread self tapping screws. Rotate screw counterclockwise until you feel threads line up before threading into hole. Screw should enter hole easily. Lettering on front of lens must be upright so beam pattern will be horizontal.

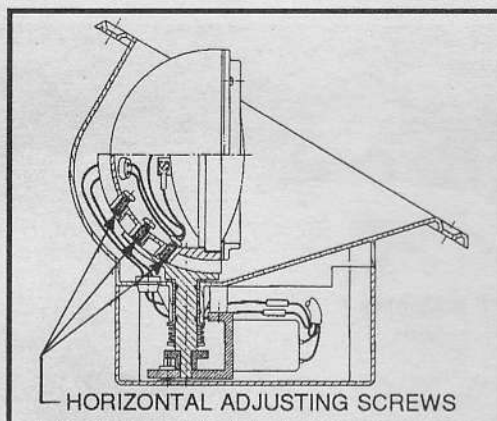

CABLE INSTALLATION

Plug each 20' cable into Y-adaptor and string cables thru bulkheads, walls, etc. to each light. Note: Secure cable to protect insulation at points of stress, and leave adequate slack where cable must be flexible.

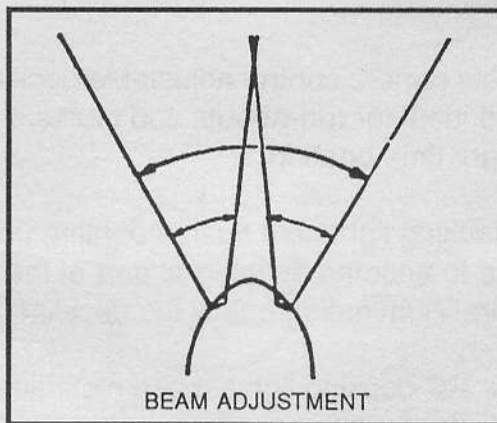

BULB REPLACEMENT

(Note bulb position before removing to aid in positioning of new bulb.)

1. To replace bulb, remove bulb retainer by removing four Philips head screws.
2. Pull bulb away from housing and disconnect the two wire terminals from bulb.
3. Connect wire terminals to new bulb and reinstall bulb into housing.
4. Reinstall bulb retainer and four screws previously removed. **CAUTION: Be careful not to cross thread self tapping screws. Rotate screw counterclockwise until you feel threads line up before threading into hole. Screw should enter hole easily.**

Note: Lettering on front of lens must be upright so beam pattern will be horizontal.

WIRING DIAGRAM

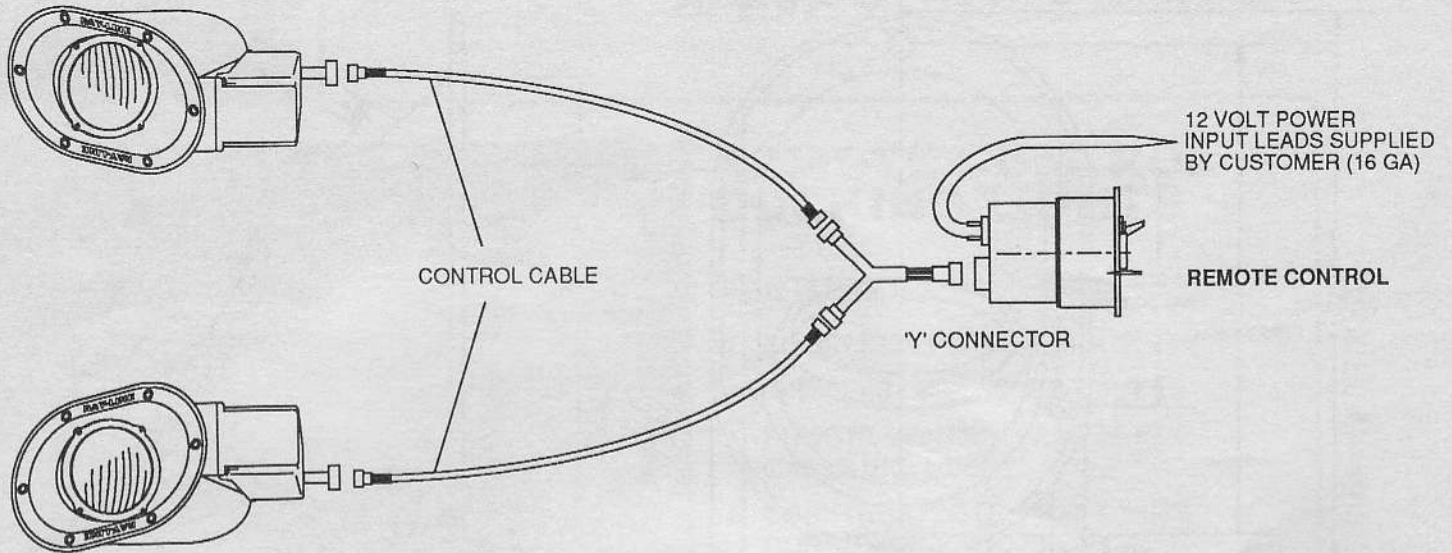

EXPLODED VIEW

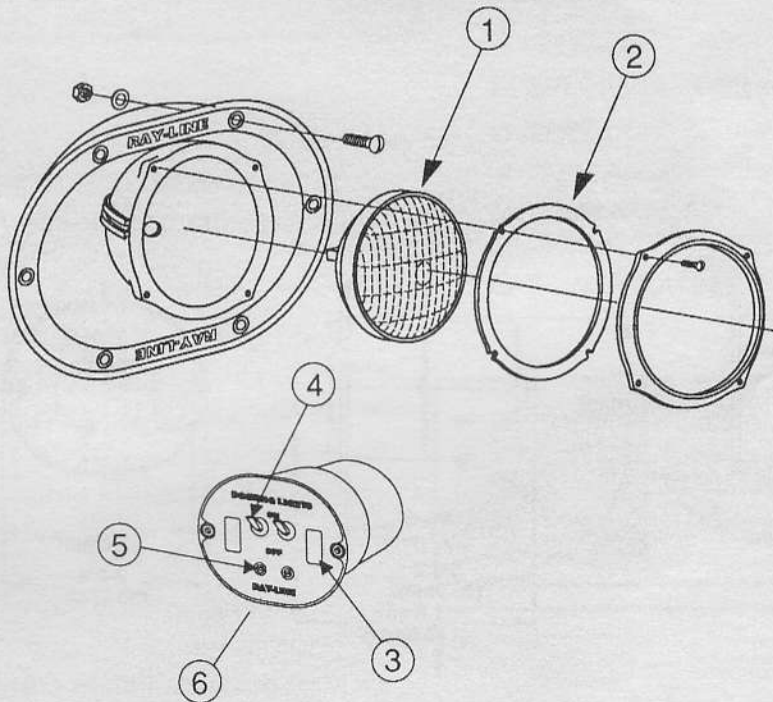

PARTS LIST

KEY	DESCRIPTION	PART NUMBER	QTY.
1	Bulb	18753-0287	1
2	Gasket	18753-0292	1
3	Fuse/Cap Kit	18753-0291	1
4	On/Off Switch	18753-0293	1
5	Directional Switch	18753-0294	1
6	Control Complete (12V)	18573-0433	1
7	* Cable 20'	18753-0288	1
8	* Cable 10'	18753-0289	1
9	* Y-Connector	18753-0290	1
10	Replacement Motor Kit	18753-0460	1
11	* Dual Station Control Kit 12V	18753-0439	1

*Not shown

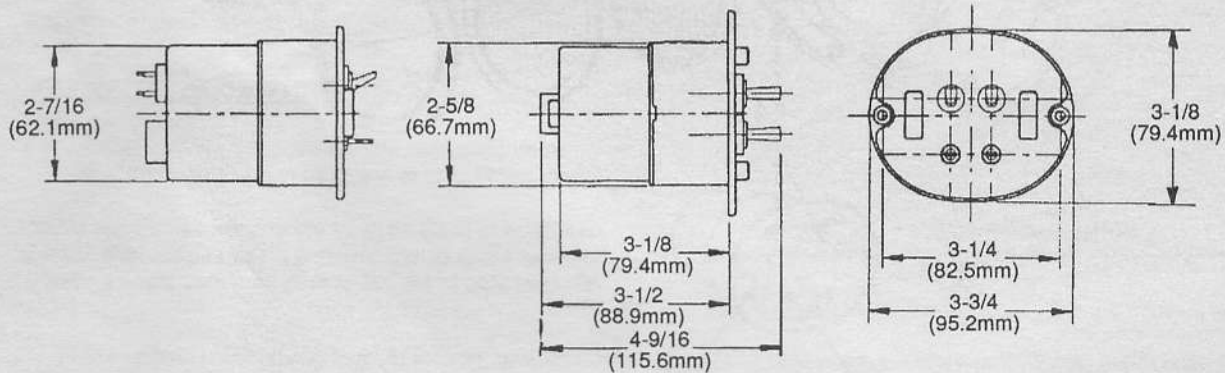
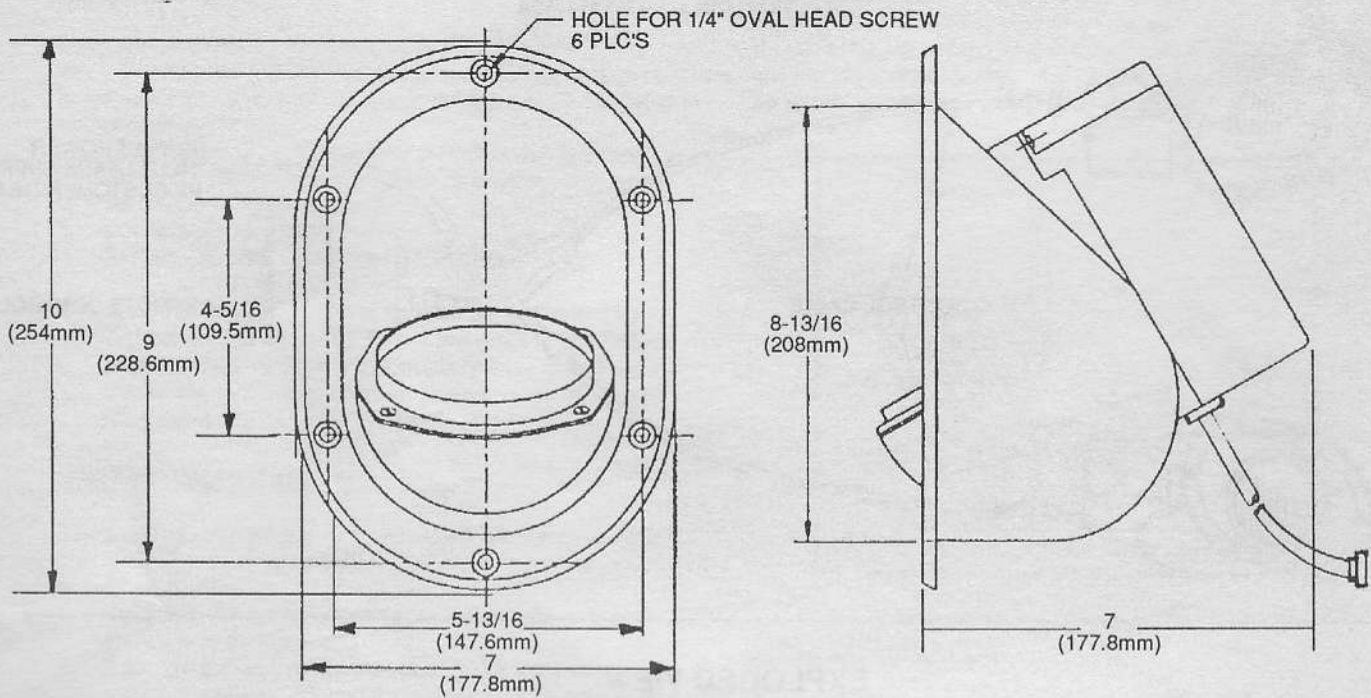

THE PRODUCTS DESCRIBED HEREIN ARE SUBJECT TO THE JABSCO® ONE YEAR LIMITED WARRANTY, WHICH IS AVAILABLE FOR INSPECTION UPON REQUEST.

ITT Jabsco

ITT Fluid Technology Corporation
1485 Dale Way, P.O. Box 2158, Costa Mesa, Ca 92628-2158
Tel: (714) 545-8251; Fax: (714) 957-0609
Bingley Road, Hoddesdon, Hertfordshire EN11 OBU, England
Tel: 0992-467191; Tlx: 26351 G; Fax: 0992-467132

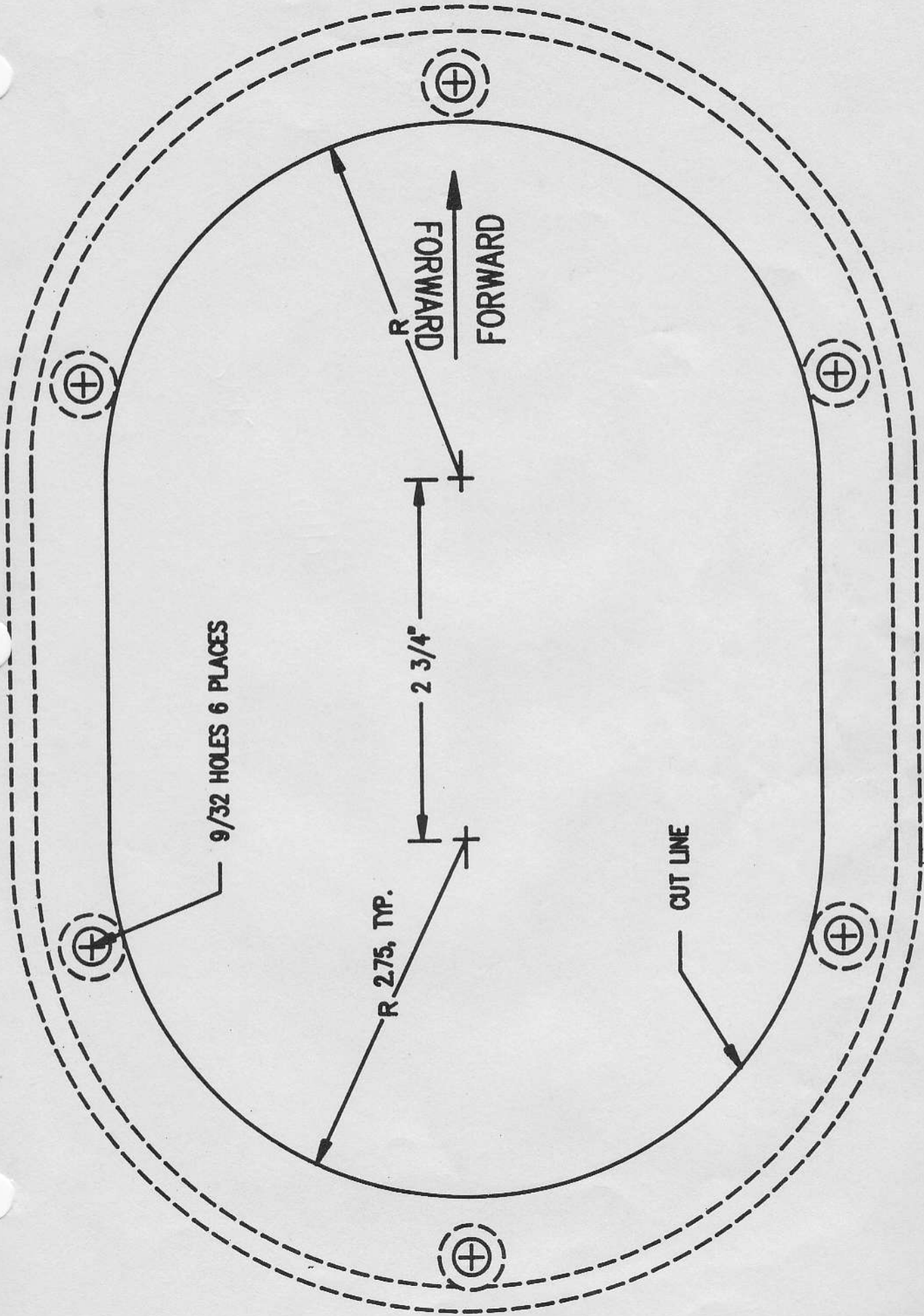

DOCKING LIGHT CUT-OUT

SCALE: FULL