



Models 41700 / 51700 - Series Washdown Pump

Models 41700 / 51700 - Series

WASHDOWN PUMP

80 PSI (5.5 BAR)

7.5 GPM (29 LPM)

6.0 GPM (23 LPM)

FEATURES

- High Pressure / High capacity
- Pumpgard™ Intake Strainer and Pressure Nozzle Included (Suitable for Use in Salt Water)
- Corrosion Resistant
- Soft Rubber Mounts
- Snap-fit Port Fittings
- 12 and 24 VDC Models
- Self-Priming up to 6 feet (1.8 m)
- Motor Rating: IP 54
- ISO 8846 MARINE (Ignition Protection)
- **CE**



SPECIFICATIONS

- Pump Body- Glass Filled Nylon
- Pump Design- 5 Chamber Diaphragm
- Suction Lift- Self Priming to 6 ft. (1.8m)
- Ports- 3/4" (19 mm) Hose Barb, 1/2" - 14 QEST straight, 3/4" (19 mm) Hose Barb 90° elbow, 1/2" - 14 QEST 90° elbow
- Motor- Permanent Magnet



WASHDOWN PUMP Dimensions English (SI)

Pump Series	Height inches (mm)	Length inches (mm)	Width inches (mm)	Weight Lb (Kg)
41700	7.3 (185)	11.8 (300)	6.1 (155)	8.0 (3.6)
51700	7.3 (185)	10.2 (259)	6.1 (155)	9.5 (4.3)

Model	Nominal DC Volts	Amp Draw (A) @10 psi (0.7 bar)	Fuse Size (A)	Open Flow GPM (LPM)	Switch Max PSI (bar)	Inlet Strainer	Nozzle
41700 - 0092	12	9.0	25	6.0 (23)	80 (5.5)	Yes	Yes
41700 - 0094	24	4.5	15	6.0 (23)	80 (5.5)	Yes	Yes
51700 - 0092	12	13.5	40	7.5 (29)	80 (5.5)	Yes	Yes
51700 - 0094	24	6.8	20	7.5 (29)	80 (5.5)	Yes	Yes

Dimensional Drawing

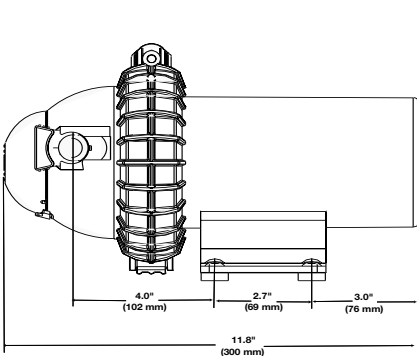

41700-Series

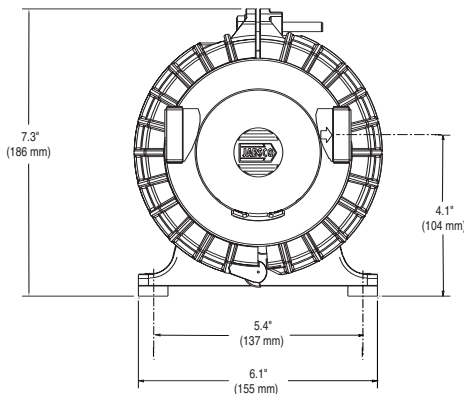

41700/51700 SERIES

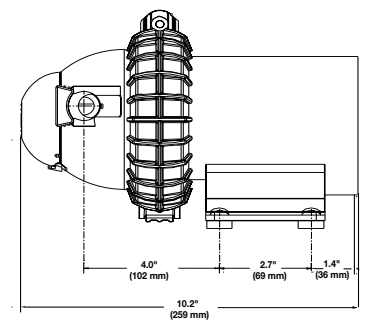

51700-Series

Performance data based upon tests at 13.6 V (12V) and 27.2 V (24V)

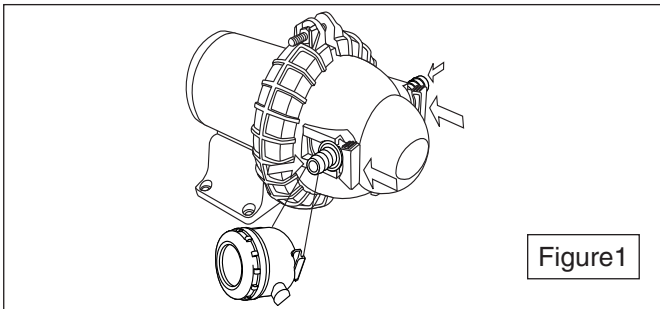

Figure 1

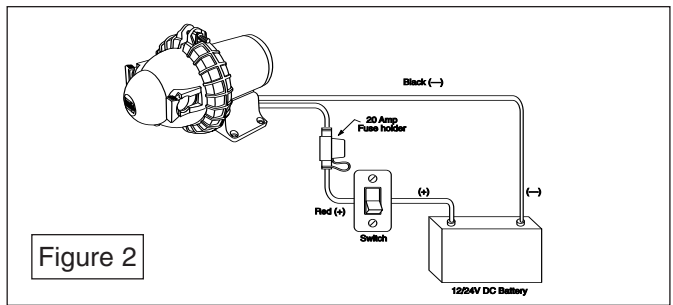

Figure 2

INSTALLATION (Fig.1)

Remove shipping plugs from the pump ports. There may be a slight amount of water that drains out of the pump as all pumps are tested at the factory before shipment. A direction arrow can be found on the pump head to indicate direction of flow. Insert Pumpgard™ strainer into pump intake port. Snap the gate closed to retain the strainer firmly in the pump body. The strainer should be checked on a regular interval to remove debris. Blockage will affect the pump and motor life and flow performance. Connect the discharge fitting of the pump, utilizing the selection to a faucet, bib or valve. Use 3/4" (19 mm) or 1" (25 mm) braided reinforced hose and a worm screw hose clamp for hose connection to all fittings.

MOUNTING

The Washdown pumps are self-priming and may be located above or below the water supply in a dry location. To vertically mount these units, it is best to do so with the motor on top. This will prevent water dripping on the motor in the event of a leak. Place pump on a solid surface and secure with the four mounting screws; be careful not to compress the rubber grommets, which act as vibration dampers.

IF YOU ARE NOT FAMILIAR WITH APPLICABLE ELECTRICAL STANDARDS, HAVE THE UNIT INSTALLED BY A QUALIFIED ELECTRICIAN.

IT IS RECOMMENDED THAT MARINE GRADE REINFORCED HOSE BE USED FOR ALL PLUMBING WITH THESE MODELS OF WASHDOWN PUMPS

WIRING

Suggested wiring information is given as a reference. For proper information, please reference USCG regulations for marine applications and wiring gauges, connectors and fuse protection.

STEP 1

Determine the distance from the power source to the pump and then double the measurement. Wire gauge installation is determined on the entire run length, to the pump and back. For wire gauge recommendations, please see the charts on the last page.

STEP 2

Connect to power supply lead (red)(+) to the positive (+) terminal on the battery or through a properly installed fuse / circuit breaker panel. Then run the length of wire to the pump, connecting the red wire through a switch appropriately rated to the pump's current requirements.

STEP 3

Route the wire so as not to create hazards in operation of the engine, movement of steering components or human traffic.

STEP 4

Connect the red lead to the red/orange lead on the pump housing located pressure switch.

STEP 5

Connect the black lead from the pump to the ground or negative power side (-) of the vessel.

STEP 6

Turn the system off when not in use for extended periods of time or when the water supply tank is empty.

STEP 7

After installation, check voltage at the pump motor. Voltage should be checked when pump is operating. Full voltage must be available at the pump motor at all times for proper pump operation and pump motor life.

PLUMBING

41700 / 51700 - Series. Washdown/Livewell (Fig. 3)

Install the Pumpgard™ strainer (provided) to the hose from the water source (thru-hull seacock or water tank). Connect the strainer to the pump inlet port. Connect the pump discharge to a 3-way valve or T (if livewell has a shutoff valve). Connect to livewell and to hose bib. From hose bib use supplied pressure nozzle.

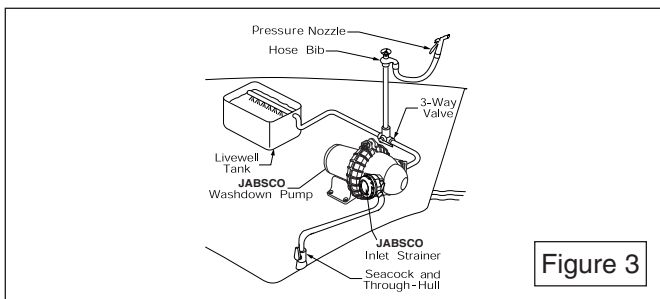

Figure 3

41700 / 51700 - Series. w/Rule® Dual Port (Fig. 4)

Install Rule® dual port pump to seacock. Connect hose from dual port pump to livewell/baitwell tank (see Fig. 4). Connect washdown hose from dual port pump to strainer, connect to pump inlet port. Connect hose from pump outlet to pressure nozzle.

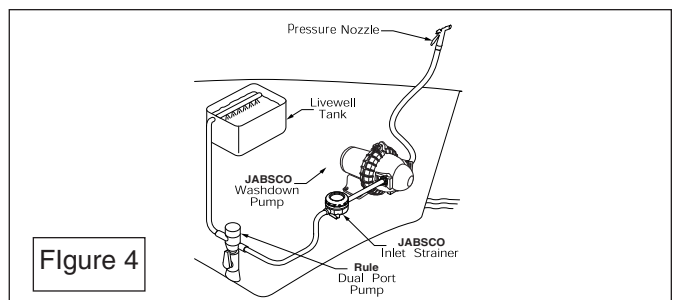
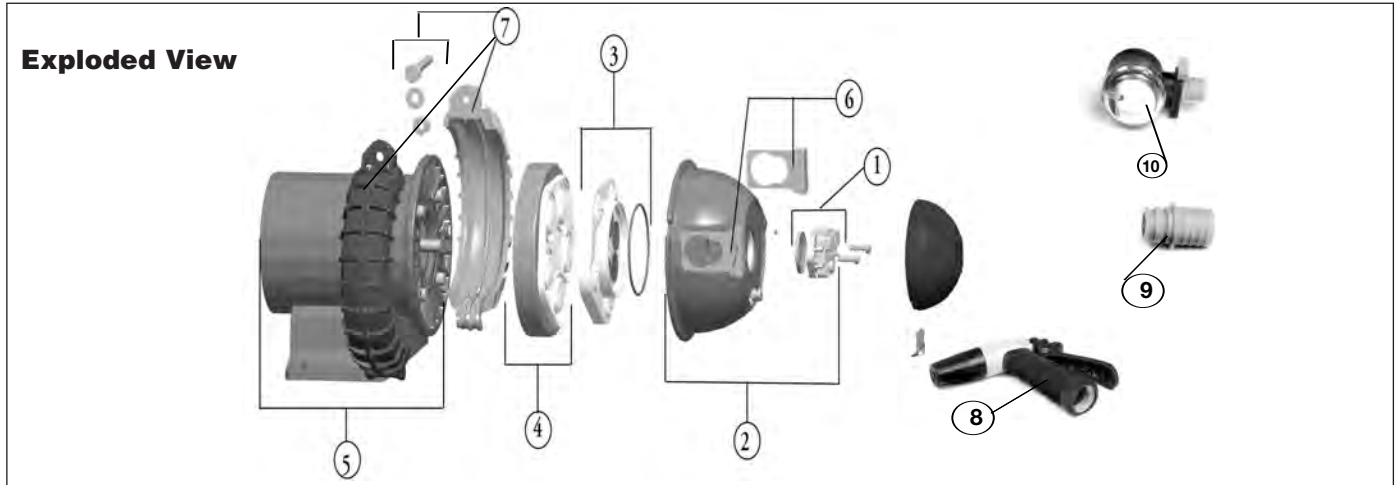

Figure 4

OPERATION

1. Open seacock (washdown or livewell applications).
2. Open hose bib and/or pressure nozzle.
3. Turn on pump.
4. Close pressure nozzle/hose bib when water runs free of air. Pump is now ready for automatic demand operation.
5. For prolonged operation, pump must operate at full open flow or motor will overheat.

CAUTION Motor case could get hot during extended operation. Prolonged contact with skin may cause a burn.



Service Parts		Part Number			
Key	Description	41700 - 0092	41700 - 0094	51700 - 0092	51700 - 0094
1	Pressure Switch	18753 - 5019	18753 - 5019	18753 - 5019	18753 - 5019
2	Upper Housing	18753 - 5009	18753 - 5009	18753 - 5009	18753 - 5009
3	Check Valve Assembly	18753 - 5006	18753 - 5006	18753 - 5006	18753 - 5006
4	Lower Housing Assembly	18753 - 5038	18753 - 5038	18753 - 5000	18753 - 5000
5	Motor With Baseplate	18753 - 5022	18753 - 5026	18753 - 5024	18753 - 5028
6	Clips	18753 - 5021	18753 - 5021	18753 - 5021	18753 - 5021
7	Clamps	18753 - 5018	18753 - 5018	18753 - 5018	18753 - 5018
8	Pressure Nozzle	30702 - 1000	30702 - 1000	30702 - 1000	30702 - 1000
9	Nozzle Adapter	50647 - 1000	50647 - 1000	50647 - 1000	50647 - 1000
10	Pumpgard™ Strainer	46400 - 0711	46400 - 0711	46400 - 0711	46400 - 0711

TROUBLESHOOTING

WARNING: BEFORE SERVICING PUMP, TURN OFF POWER TO PUMP AND DRAIN SYSTEM!!

Failure to Prime - Motor operates, but no water flows

- Debris in pump:
- Defective check valve assembly:
- Air leak in intake line:
- Restricted intake or discharge line:
- Punctured diaphragm (pump leaks):
- Crack in pump housing (pump leaks):
- Empty water supply tank:

Motor fails to run

- Pump circuit has no power:
- Loose or corroded wiring connection:
- Blown fuse or open breaker:
- Open thermal protector (motor shell hot):
- Defective motor:

Pump fails to turn off after all fixtures are closed

- Empty water supply tank:
- Air trapped in pump:
- Debris in pump:
- Defective check valve assembly:
- No battery in circuit:
- Punctured diaphragm (pump leaks):
- Discharge line leak:

Low flow or pressure

- Debris in inlet strainer:
- Water filter needs changing:
- Under-sized plumbing or long runs:
- Defective motor:
- Loose or corroded electrical connections:
- Inadequate wire gauge

Remedy

Remove upper-housing and clean
 Replace check valve assembly
 Tighten all clamps, inspect plumbing
 Remove lines and inspect
 Replace lower housing assembly
 Replace housing or pump head
 Refill or turn off power to pump

Check wiring, fuse or breaker
 Inspect wire connections
 Replace or reset
 Wait 20 to 30 minutes for auto reset
 Replace motor

Refill
 Open faucet closest to pump
 Remove upper-housing and inspect
 Replace check valve assembly
 Install battery
 Replace lower housing assembly
 Inspect plumbing for leaks

Remove cover and clean screen
 Replace filter cartridge
 Increase plumbing I.D.
 Replace motor
 Inspect wire connections
 Inspect wire gauge

ACCESSORIES

Quick - Connect Port System

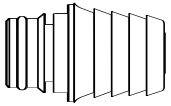

50640 - 1000
(1 PAIR)
SNAP - IN X
1" (25 mm)
HOSE BARB
STRAIGHT

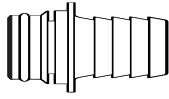

50642 - 1000
(1 PAIR)
SNAP - IN X
3/4" (19 mm)
HOSE BARB
STRAIGHT

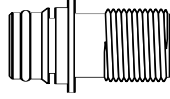

50644 - 1000
(1 PAIR)
SNAP - IN X
1/2" - 14 QEST
STRAIGHT

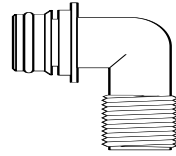

50645 - 1000
(1 PAIR)
SNAP - IN X
1/2" - 14 MALE QEST
90° ELBOW

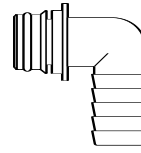

50643 - 1000
(1 PAIR)
SNAP - IN X
3/4" (19 mm)
HOSE BARB
90° ELBOW

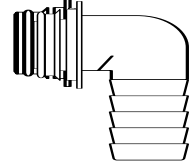

50641 - 1000
(1 PAIR)
SNAP - IN X
1" (25 mm)
HOSE BARB
90° ELBOW

Wiring Guide For 5 - Chamber Pump

These charts reflect the 3% voltage drop classifications appearing in ABYC's E-11 AC & DC ELECTRICAL SYSTEMS ON BOATS. Wire resistances were taken from NFPA NEC 2002 Handbook, Table 8.

The percentage voltage drops will approximate percentage reductions in open flow from ideal.

41700-0092

Operating Current:	17 A
Fuse Size:	25 A

Wire sizing for 3% voltage drop, 1-way wiring run				
AWG	5' (1.5m)	10' (3m)	20' (6m)	30' (9m)
14				
12				
10				
8				

41700-0094

Operating Current:	8.5 A
Fuse Size:	15 A

Wire sizing for 3% voltage drop, 1-way wiring run				
AWG	5' (1.5m)	10' (3m)	20' (6m)	30' (9m)
14				
12				
10				
8				

51700-0092

Operating Current:	29 A
Fuse Size:	40 A

Wire sizing for 3% voltage, 1-way wiring run				
AWG	5' (1.5m)	7.5' (2.3m)	10' (3m)	20' (6m)
10				
8				
6				
4				

51700-0094

Operating Current:	15 A
Fuse Size:	20 A

Wire sizing for 3% voltage drop, 1-way wiring run				
AWG	7.5' (2.3m)	10' (3m)	20' (6m)	30' (9m)
14				
12				
10				
8				

Jabsco



ITT Industries
Engineered for life

www.jabsco.com

THE PRODUCTS DESCRIBED HEREIN ARE SUBJECT TO THE JABSCO THREE YEAR LIMITED WARRANTY, WHICH IS AVAILABLE FOR YOUR INSPECTION UPON REQUEST.

U.S.A	UK	CANADA	JAPAN	GERMANY	ITALY
Jabsco	Jabsco	Fluid Products Canada	NHK Jabsco Company Ltd.	Jabsco GmbH	Jabsco Marine Italia
Cape Ann Industrial Park	Bingley Road, Hoddesdon	55 Royal Road	3-21-10, Shin-Yokohama	Oststrasse 28	Via Tommaseo, 6
Gloucester, MA 01930	Hertfordshire EN11 OBU	Guelph, Ontario N1H 1T1	Kohoku-Ku, Yokohama, 222	22840 Norderstedt	20059 Vimercate, Milano
Tel: +1 978 281 0440	Tel: +44 (0) 1992 450145	Tel: 519 821 1900	Tel: +45 475 8906	Tel: +49 (40) 53 53 730	Tel: +39 039 685 2323
Fax: +1 978 283 2619	Fax: +44 (0) 1992 467132	Fax: 519 821 2569	Fax: +45 475 8908	Fax: +49 (40) 53 53 7311	Fax: +39 039 666 307