

MODEL 40960-Series 8" Electric Remote Control

PRODUCT DATA

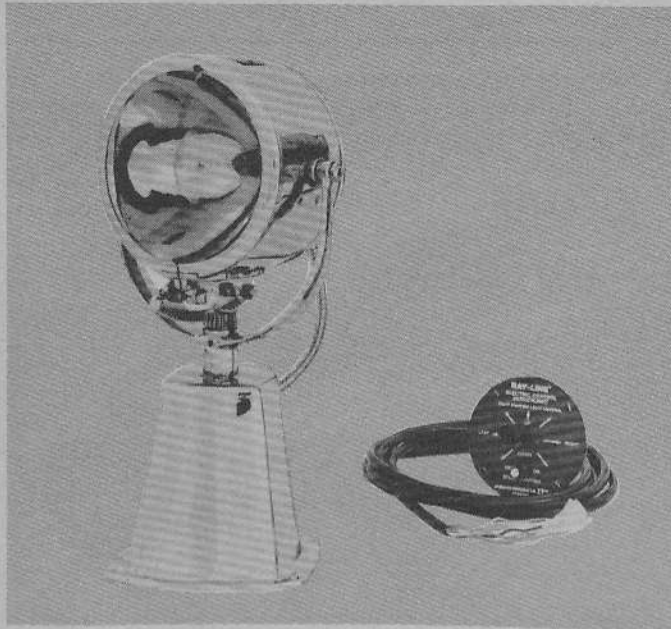

FEATURES

- Completely motorized drive unit in base.
- Slip-clutch design prevents accidental damage to drive unit.
- Built-in brake holds light head firmly on target.
- Includes eight-position control for horizontal, vertical, and simultaneous motor operation.
- Speed control for fast or slow movement in all directions.
- Heavy copper, brass, and bronze construction.
- Precision formed polished chrome plated parabolic reflector.
- Double contact bayonet type projector bulb.
- External focusing for spot or flood beam.
- Simple plug-in cable assembly included.
- High quality nickel chrome plated finish.
- Approximate shipping weight: 25 lbs.

MODEL 40960-SERIES
8" ELECTRIC REMOTE CONTROL

INSTALLATION INSTRUCTIONS

Model No.	Finish	Voltage	Bulb No.	Fuse Size
40960-0000	Chrome	12	98039-0020	10 Amp.
40960-0001	Chrome	24	98029-0050	5 Amp.
40960-0002	Chrome	32	98039-0060	5 Amp.

All models includes main control and 8 ft. interconnecting cable. Optional secondary control number 42640-0001, includes 8 ft. interconnecting cable.

Select a location for the light which will allow clear beam projection forward and as far aft as possible. Searchlight base should be mounted on level, flat surface. See dimensional drawing for mounting hole pattern and clearance hole for cable plug.

Choose a location for main control near the helm which will permit convenient operation of directional control lever and speed control knob. Control may be mounted on vertical, horizontal, or inclined panel. Provide for routing of interconnecting cable from light to control. Note plug dimensions on dimensional drawing so adequate clearance can be provided along cable route.

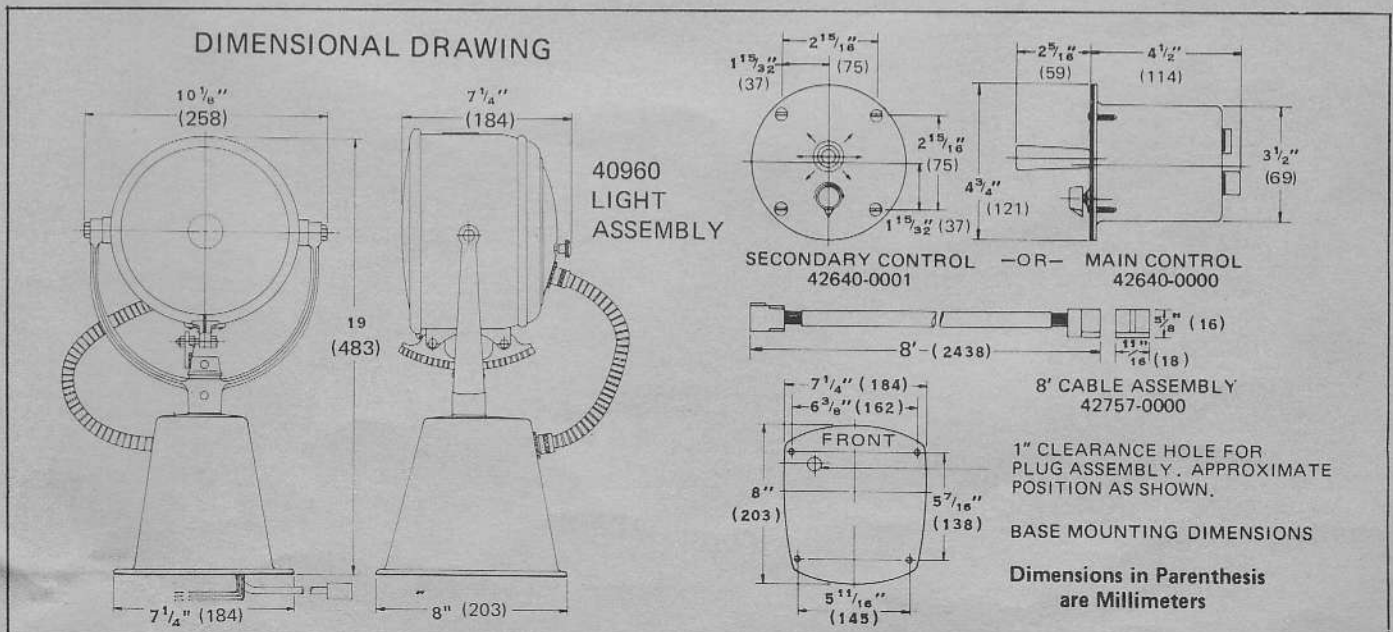

INSTALLATION INSTRUCTIONS (CONT'D.)

Position gasket under base, feed wires through clearance hole and fasten base securely with four screws provided. Cut a $3\frac{5}{8}$ " hole for control in desired location. Do not cut hole larger than $3\frac{5}{8}$ " so adequate material will be left to install face plate mounting screws. Chamfer top edge of the hole about $\frac{1}{8}$ " for radius in control housing.

Remove two temporary screws in face plate. Use control unit with face plate as template for marking holes for four mounting screws. Position control in the panel and mount with four screws provided.

Connect cable and DC power source as shown in wiring diagram. If additional cable length is required, order optional 8 ft. cable and plug assembly no. 42757-0000.

OPERATING INSTRUCTIONS

To turn light on, rotate the ON-OFF-SPEED control knob clockwise to about mid position. To move light head, push the control lever in the direction the beam is to move.

The control lever has eight contact positions, and will operate in horizontal, vertical, and in four intermediate directions.

The speed control varies the speed of head movement in all directions. Turn clockwise to increase speed, counterclockwise to decrease speed. To turn light off, rotate the speed control knob counterclockwise until light clicks off.

WIRING DIAGRAM FOR MAIN CONTROL AND OPTIONAL SECONDARY CONTROL

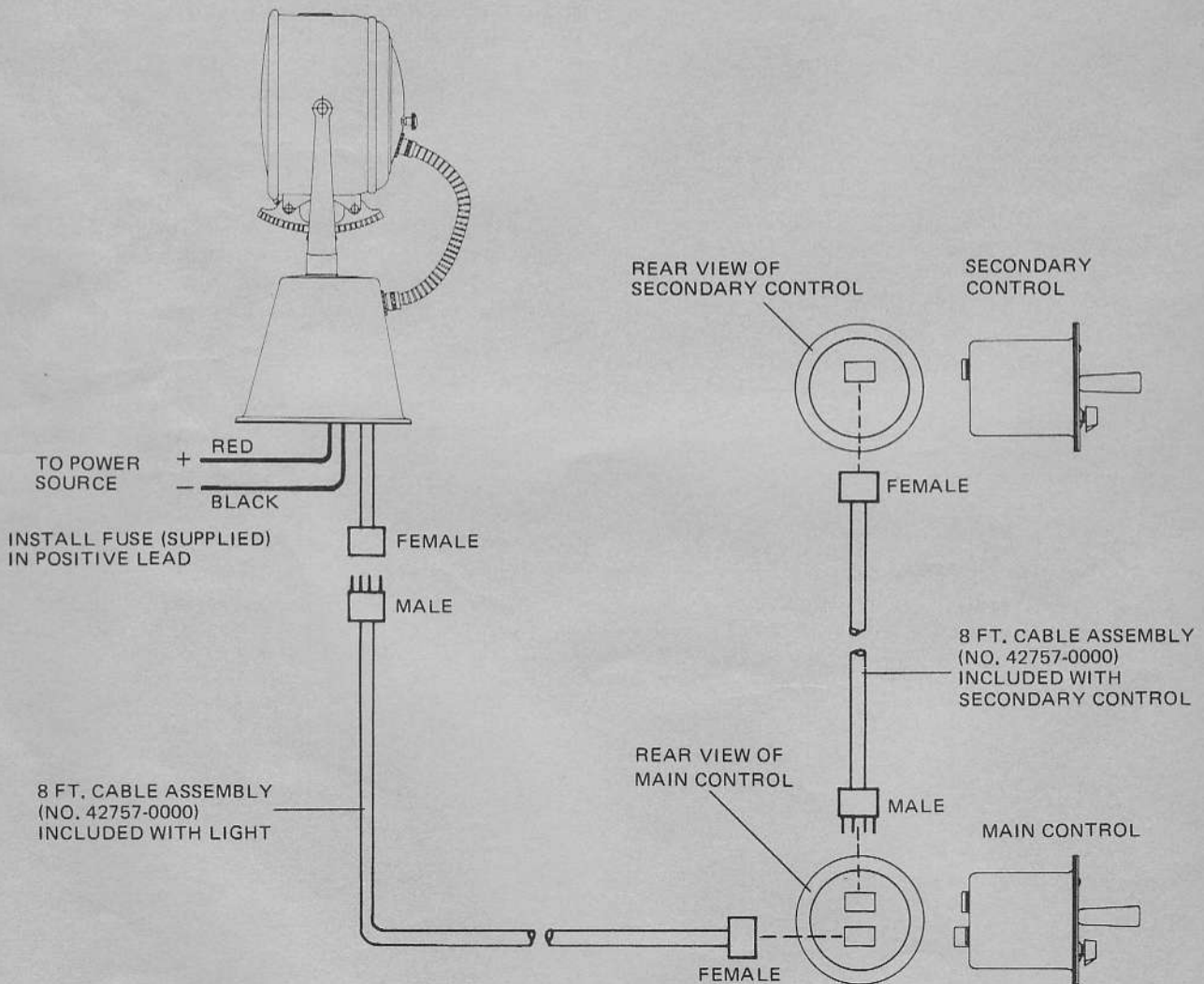

If additional cable is needed for main or secondary control connections, order 8 ft. cable assembly (no. 42757-0000) with mating plugs.

PARTS VIEW

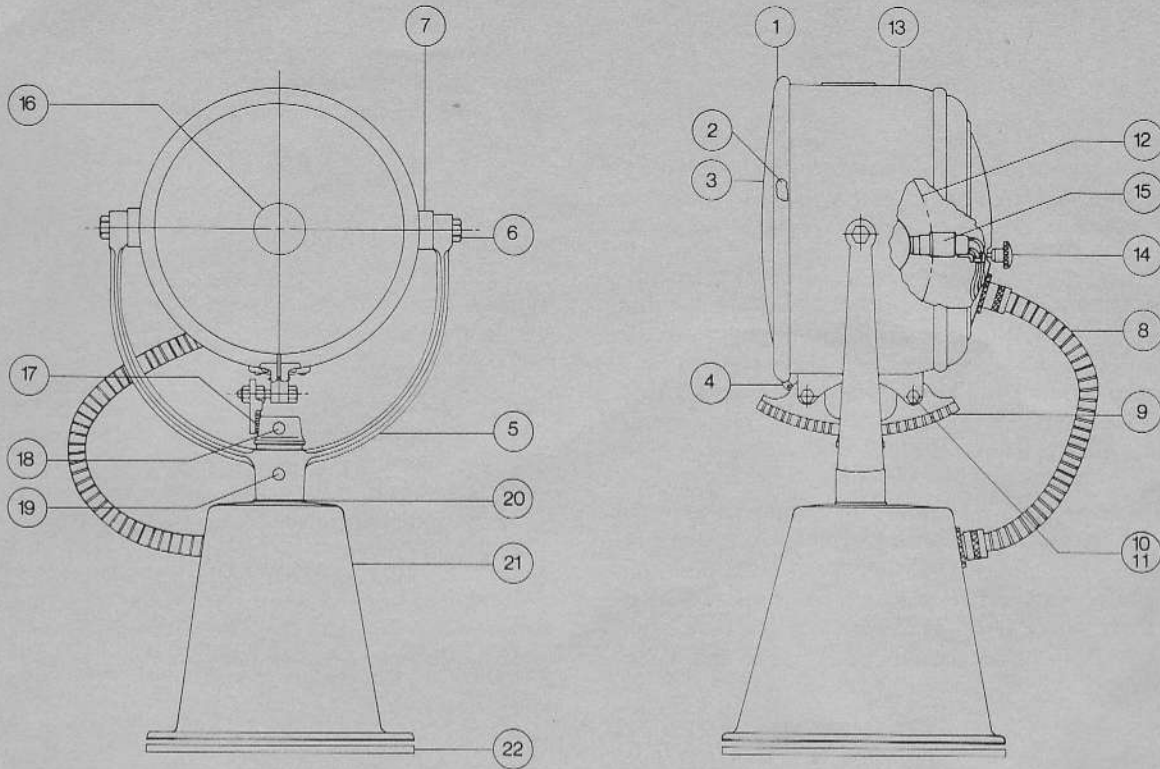

PARTS LIST

KEY	PART DESCRIPTION	PART NO.	QTY.
1	Door Only (less lens)	40834-0010	1
2	Gasket for Lens	96010-0110	1
3	Lens	90844-0060	1
4	Screw for Door	91001-0060	1
5	Trunnion	40814-0040	1
6	Bolt for Trunnion	43265-0010	2
7	Set Screw for Housing	96091-0011	2
8	Conduit Assembly	40518-0110	1
9	Quadrant Gear	40819-0000	1
10	Quadrant Bolt	43264-0010	2
11	Quadrant Nut	43252-0010	4
12	Reflector Assembly	40548-0000	1
13	Housing	40838-0020	1
14	Focusing Assembly	43395-0030	1
15	Socket Assembly	40568-0010	1
16	Bulb - 12V	98039-0020	1
	Bulb - 24V	98039-0050	1
	Bulb - 32V	98039-0060	1
17	Pinion Gear	40821-0020	1
18	Pinion Set Screw	96091-0020	1
19	Trunnion Set Screw	96091-0010	2
20	Thrust Washer	43190-0020	2
21	Base Assembly, 12 VDC	43070-0000	1
	Base Assembly, 24 VDC	43070-0001	
	Base Assembly, 32 VDC	43070-0001	
22	Base Gasket	43056-0000	1
(Not Shown)	Main Control	42640-0000	1
(Not Shown)	Secondary Control (optional)	42640-0001	
(Not Shown)	8 ft. Cable Assembly	42757-0000	

SERVICE INSTRUCTIONS

RELAMPING AND FOCUSING: Remove door (Key 1). Remove bulb by pushing in and turning counterclockwise. Install new bulb by pushing in and turning clockwise. Replace door and clamp. Adjust focusing knob (Key 18) for desired beam width.

MAINTENANCE: Clean the bulb, reflector, and lens with a soft, lint-free cloth periodically for best efficiency. Apply a coating of all-weather grease to moving parts as required.

MAJOR SERVICE: Control assembly or base drive unit assembly should be returned to the factory at 501 W. Liberty St., Springfield, Ohio 45501, for service.

To return main or secondary control, remove complete unit and unplug cable connections. Tape or fasten face plate to housing and return complete assembly to the factory.

To return base assembly, disconnect power connections and cable plug from light base. Remove complete light assembly from installation. To disassemble light head from base, remove plate from bottom of base and disconnect the two wires from the conduit to the terminal block inside the base. Unscrew conduit ferrule at base and pull out conduit and wires.

Remove pinion and trunnion set screws (Key 18 and 19). Lift complete light head from base. Return the base assembly only, including the plate removed for access to the terminal block. Base unit will be completely serviced and returned for installation of light head.

To install light head after service, feed conduit through the connection in the base, connect conduit, and tighten ferrule. Connect conduit wires to terminal strip no. 1 (marked TB 1) at terminals 3 and 4.

Replace base plate, center clearance hole on shaft assembly and fasten with four screws. Connect power supply and cable plug. Remount light base.

Before mounting light head, be sure thrust washers (Key 24) are in place. Rotate spindle to full aft position with control lever, and install light head facing aft. Tighten both trunnion set screws lightly, then alternately tighten each of the set screws until tightened firmly.

Replace the pinion gear and tighten both set screws securely. Operate light in all directions to be sure trunnion is correctly positioned on spindle to permit full 360° operation. No further adjustments should be necessary.

JABSCO PRODUCTS **ITT**

Marine and Recreation Components Division
International Telephone and Telegraph Corporation
1485 Dale Way, Costa Mesa, California 92626

Telephone: (714) 545-8251