

Model 37202-Series

Model 37202-Series

ELECTRIC BILGE PUMPS

FEATURES

- Pumpguard Inlet Strainer Supplied With Pump
- Self-Priming
- Diaphragm Design Allows Dry Running
- Built-in Hydraulic Pulsation Dampener
- Corrosion Resistant Materials Throughout for Sea Water Service
- Meets USCG Electrical Regulation 183.410 and ISO 8846 Marine for Ignition Protection.
- N.M.M.A. Type Accepted

SPECIFICATIONS

- Open Flow:** 4.5 GPM
Vert. Dry Suction Lift: 7 feet
Ports: 3/4" Slip-on Hose
Weight: 5.5 lb (2,5 kg)

INSTALLATION

MOUNTING

Mount upright in a dry location (above highest bilge water level) on a solid surface. Mounting screws should be tightened only enough to slightly compress grommets. Overtightened screws will reduce cushioning effect of mounts and may cause excessive noise.

PLUMBING

For intake and discharge, use 3/4" ID non-collapsible hose. Keep intake and discharge lines free of kinks and restrictions. To protect pump from debris, install the 3/4" in-line strainer (Model 36200-0000) in the intake line from the bilge. Use a 3/4" thru-hull fitting for discharge located well above the waterline at all angles of heel.

WIRING

Wire pump in a circuit independent of all other electrical fixtures. Use stranded copper wire. Install fuse in positive circuit. See table for recommended wire and fuse size. See diagram for wiring connections. Use a 10 amp-rated switch (3-way switch Model 44960-0001). After installation, it is recommended that voltage be checked at the motor terminals with motor operating under full load. Be sure measured voltage is not less than 11 volts on a 12 volt system with a fully charged battery.



STANDARD MODELS

Model	Voltage	Nominal Current	Fuse Size
37202-0000	12 Vdc	7.5 AMP	10 AMP
37202-0010	24 Vdc	6.5 AMP	10 AMP

MAINTENANCE

LUBRICATION: Check connecting rod bearing annually and add chassis lube as needed. No other lubrication of the pump is required.

WINTER STORAGE: The pump must be completely drained, hoses removed and pump run until all water is expelled.

WIRING TABLE

Wire Length Between Battery and Motor	Wire Gauge
1 - 25 feet	12 AWG
25 - 50 feet	10 AWG

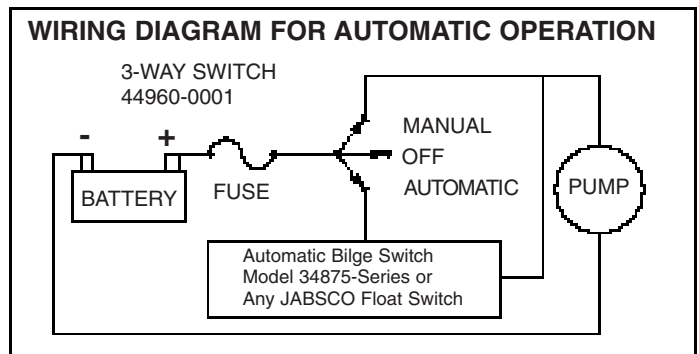
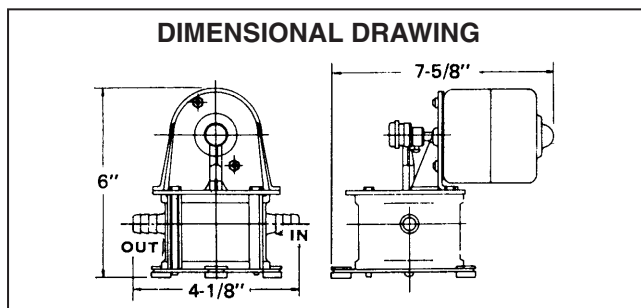

EXPLODED VIEW

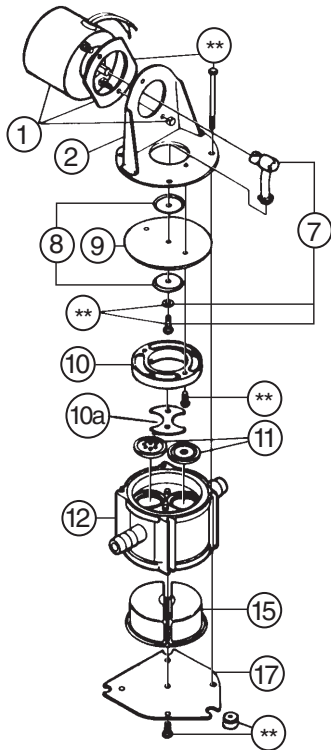

**Indicates items included in Hardware Kit (Key 21)

PARTS LIST

37201/37202-SERIES

KEY	DESCRIPTION	PART NUMBER	QTY.
1	Motor Kit 12 Vdc	30201-0000	1
1	Motor Kit 24 Vdc	30200-0040	1
2	Motor Mount	35797-0000	1
7	Connecting Rod Kit	30040-0000*	1
8	Diaphragm Plate	35688-0000	2
9	Diaphragm	37174-0000*	1
10	Retainer	35788-0000	1
10a	Valve Retaining Plate	35816-0000	1
11	Valve Set (Inlet & Outlet)	30005-0000*	1 Set
12	Base	35795-0000	1
15	Pulsation Dampener	37179-0000*	1
17	Bottom Plate	35798-0000	1
21	Hardware Kit	37168-0000	1 Set
	Service Kit	37182-0000	

* Indicates Parts Contained in Service Kit.

NOTE 1 – For Model 37201-0000 Use Replacement Motor Number 30202-0000 (12 Volt only).

NOTE 2 – For Model 37201-0000 Use 2 Each 35983-0000 Diaphragm Plates.

Jabsco



U.S.A.
Jabsco
20 Icon
Foothill Ranch, CA 92610-3000
Tel: 949.609.5106
Fax: 949.859.1254

UNITED KINGDOM
Jabsco
Bingley Road, Hoddesdon
Hertfordshire EN11 OBU
Tel: +44 (0) 1992 450145
Fax: +44 (0) 1992 467132

CANADA
Fluid Products Canada
55 Royal Road
Guelph, Ontario N1H 1T1
Tel: (519) 821.1900
Fax: (519) 821.2569

JAPAN
NHK Jabsco Company Ltd.
3-21-10, Shin-Yokohama
Kohoku-Ku, Yokohama, 222
Tel: 045.475.8906
Fax: 045.475.8908

GERMANY
Jabsco GmbH
Oststrasse 28
22840 Norderstedt
Tel: +49-40-53 53 73 -0
Fax: +49-40-53 53 73 -11

SERVICE

TROUBLE SHOOTING

Problems	Causes
Loss of suction to pump:	- Air leak in suction line. - Bilge pickup not submerged. - Intake hose kinked or plugged. - Fouled intake or discharge valve. - Ruptured diaphragm.
Rough or noisy operation:	- Intake or discharge hose kinked or plugged. - Pump not mounted firmly. - Loosened eccentric set screw or worn connecting rod bearing. - Ruptured or collapsed pulsation dampener.

VALVE REPLACEMENT

1. Turn off power to pump. Remove four tie down bolts.
2. Expose valves by lifting motor mount and the attached diaphragm assembly from pump base.
3. Remove and clean or replace valves.
4. Install valves, making sure rubber flapper is UP on intake and DOWN on discharge. Replace valve retaining plate.
5. Replace motor-mount-diaphragm assembly and fasten evenly to base with the four tie down bolts.

DIAPHRAGM AND CONNECTING ROD REPLACEMENT

1. Turn off power to pump. Remove four motor mount tie down bolts.
2. Lift motor mount and the attached diaphragm assembly from pump base.
3. Remove two diaphragm retainer screws and the diaphragm retainer.
4. Pull connecting rod assembly and diaphragm from motor mount; then, unscrew bolt to separate diaphragm plates.
5. Loosely reassemble new diaphragm, diaphragm plates, washer and diaphragm bolt onto new connecting rod assembly.
6. Slide connecting rod on shaft. Ensure that eccentric is firmly seated on motor shaft and tighten set screw firmly against flat side of shaft.
7. Loosely reassemble diaphragm, diaphragm plates, washer and diaphragm bolt onto connecting rod. Tighten connecting rod bolt while maintaining alignment of rod bearing eccentric. **NOTICE:** Avoid misalignment or twisting of rod on eccentric shaft or excessive bearing wear will result.

PULSATION DAMPENER REPLACEMENT

1. Disconnect power leads from pump and remove from mount. Remove four tie down bolts.
2. Remove bottom plate screw and the bottom plate. Pull out and replace pulsation dampener; position the 3-ribbed cavity on discharge side.
3. Replace bottom plate and screw. Tighten evenly to base with the four tie down bolts.
4. Reinstall pump and reconnect power leads.

PUMPGARD REPLACEMENT PARTS

Part Description	Part Number
Screen Replacement	36139-000
O-Ring Seal	36403-0000

THE PRODUCTS DESCRIBED HEREIN ARE SUBJECT TO THE JABSCO ONE YEAR LIMITED WARRANTY, WHICH IS AVAILABLE FOR YOUR INSPECTION UPON REQUEST.