

ELECTRIC TOILET BASE KIT

FEATURES

- High Capacity Macerator and Bowl Scavenger Pump
- Flexible Impeller Flush Pump
- Permanent Magnet Type Motor, Fully Enclosed, with Stainless Steel Shaft
- Complies with USCG 183.410 and ISO 8846 MARINE for Ignition Protection
- Simple Push Button Switch included
- All Corrosion Resistant Materials for Marine Use

SPECIFICATIONS

- 5/8" or 3/4" Inlet, 1" Outlet Back Flow Check Valve in Discharge
- 1" x 1-1/2" Hose Adaptor included to adapt to 1-1/2" waste plumbing.
- Thru Flow Approx. 1-1/2 Qts. per 5 Seconds of Operation

VARIATIONS

MODEL NO.	DESCRIPTION
37010-0092*	Toilet Conversion, 12 Volt EMC
37010-0097*	Toilet Conversion, 24 Volt EMC

*This model is **CE** Marked and complies with EN50081-1 for suppression of electro-magnetic interference.

APPLICATION

The Jabsco electric toilet may be installed above or below the waterline. Flush pump is self-priming with a vertical lift up to 4 feet; discharge macerator pump can operate against a vertical head up to 4 feet.

The 37010 series can be used to convert the Raritan PH or Compact, Wilcox-Crittenden "Head Mate", Groco HC, Brydon No. 9127, 9128, or No. 59128 and virtually any other model marine toilet using the "standard" bowl configuration with a 3-3/4" diameter bolt circle, 4 hole pattern in the base. Check the dimensional drawing to be sure the bowl will fit the flange dimensions as shown.

The 37010 series includes the complete motorized base assembly, bowl gasket, four bolts and washers for bowl, two 5/8" to 3/4" pump port adaptors, 3/4" white hose, 1" to 1-1/2" discharge port adaptor, and momentary control switch.

ASSEMBLY

1. Overall height after conversion may increase up to 1"



Model 37010-Series

on some models, check to be sure adequate space is available if located under seats or bunks.

2. Screw 6mm machine screws with starlock washer under each head into nuts positioned in the hex recess on the top of the base to form bowl attachment studs (see exploded view).
3. Remove complete manual base assembly and mount bowl on Jabsco motorized base. NOTE: M6 x 50mm long machine screws supplied are suitable for most bowls; however some bowl flanges are heavier and longer machine screws must be used. Place plastic washers against bowl flange, positioning base for most convenient hose connection arrangement.
4. Connect pump outlet to rear bowl connection with 3/4" hose. Install the hose clamp on the pump discharge port only.
5. Position complete toilet assembly and fasten securely on flat surface. Be sure not to warp toilet base when tightening toilet base down.
6. Connect existing inlet hose to pump inlet port. A 5/8" to 3/4" sleeve adaptor is included for fitting to commonly used 3/4" inlet hose size. Make sure all connections are airtight and free of sharp bends or restrictions.
7. Connect 1" discharge hose to discharge port (1-1/2" hose when using 1-1/2" discharge adaptor) and make suitable connection to holding tank or other discharge system. Avoid sharp bends or restrictions.
8. For installation below the waterline, install a vented loop in the intake hose and position about 8" above the waterline at all angles of heel or trim. **A vented loop should also be used for discharge if connected to a thru-hull fitting.
9. For installations above water line, make a loop in discharge line about 8 inches above base of bowl to retain water in bowl. Some installations may need a

check valve in the intake line to aid primeability of flush water pump.

- If thru-hull seacocks cannot be conveniently operated from toilet location, install suitable shut-off valves for inlet and discharge connections.

****** *In some installations when a vented loop is installed in the intake hose, the flushing pump primeability and flow characteristics are reduced and may adversely affect toilet function. To restore pump performance, connect a solenoid valve (Jabsco No. 37068-0000) to the vent air inlet to interrupt the air supply during the flush cycle. The brass port of the solenoid valve (remove plastic filter if attached) should be connected to the vent inlet with 3/16" hose and the solenoid wired in parallel with the toilet motor. See Diagram 1 for installation and wiring illustration.*

INSTALLATION INSTRUCTIONS

PLUMBING CONNECTIONS: Connect inlet hose using either 5/8" or 3/4" ID hose (a sleeve is included to adapt pump inlet from 5/8" to 3/4"). Make sure all inlet connections are airtight and free of sharp bends or restrictions.

NOTICE: The toilet inlet must *not* be connected to a pressurized water system.

Connect 1" or 1-1/2" hose to discharge port (Adaptor 98023-0080 is included to convert discharge port to 1-1/2" ID hose), and make suitable connection to holding tank or other discharge system. Avoid sharp bends or restrictions.

If the toilet is, or can be, below waterline at any normal (including static) attitude of vessel heel and/or trim, a 3/4" Vented Loop Fitting must be installed in the length of hose connecting the flushing pump to the inlet seacock. The Vented Loop Fitting must be positioned so it remains slightly* above the waterline at all angles of heel and trim.

**Recommended minimum height above waterline is 6".*

For above waterline installations, a check valve may have to be installed in the flush water intake line to ensure rapid pump priming. To retain water in bowl, make a loop in the discharge line about 8 inches above base of bowl.

⚠ CAUTION Do not connect the toilet to the vessels portable water for its source of supply. To do so can result in contamination of portable water supply. If fresh water is preferred for flushing, provide a separate fresh water tank to supply water to the toilet only.

DO NOT CONNECT INLET HOSE TO A PRESSURIZED PORTION OF THE WATER SYSTEM.

ELECTRICAL CONNECTIONS: Select a location for the switch and instruction plate, making sure wire leads from both the toilet and power source can be routed to the switch. Ensure the panel where installing switch is no more than 1" thick. Drill a 5/8" mounting hole and install switch and instruction plate. Use stranded copper wire of the correct size (determined from the electrical specifications chart) to connect one side of the switch to the positive power source.

ELECTRICAL SPECIFICATIONS

VOLTAGE	AMP DRAW	FUSE SIZE	WIRE SIZE PER FEET OF RUN*				
			0'-10' (0 M-3 M)	10'-15' (3 M-4,6 M)	15'-25' (4,6 M-7,6 M)	25'-40' (7,6 M-12,2 M)	40'-60' (12,2 M-18,3 M)
12 Vdc	16	25	#12 (4 mm ²)	#10 (6 mm ²)	#10 (6 mm ²)	#8 (10 mm ²)	#6 (16 mm ²)
24 Vdc	8	15	#16 (2,5 mm ²)	#14 (2,5 mm ²)	#12 (4 mm ²)	#10 (6 mm ²)	#10 (6 mm ²)

* Length of run is total distance from power source to product and back to ground.

NOTICE: Correct wire size and secure wire connections are very important. Undersized wire and unsecured or corroded wire connections will cause a reduction in pump performance and possible pump failure. **An appropriate size fuse or equivalent circuit breaker (determined from electrical specifications chart) must be installed in the positive power lead within seven inches of the power source or in the electrical power distribution breaker /fuse panel.** Connect the other side of the switch to the orange (positive) motor lead. Connect the black (negative) motor lead to the negative side of the battery or grounded buss bar.

NOTICE: Correct motor polarity (orange to positive, black to negative) is important. Reverse polarity can damage motor and void warranty. Full voltage at the motor is required to properly operate Jabsco Electric Toilet. The toilet must be wired in a circuit independent of all other accessories.

OPERATING INSTRUCTIONS

Make sure inlet and outlet seacocks are all open; push switch button to operate. Operate until bowl is completely flushed and discharge pump has scavenged water from bottom of bowl.

The Jabsco electric marine toilet will provide years of troublefree service if properly used. It will handle waste and toilet tissue. It will not handle rags, sanitary napkins or hard solid objects.

Clean toilet with mild non-abrasive cleaners without strong aromatics. Cleaners having high concentrations of aromatics, such as pine cleaners and strongly scented de-greaser concentrates, can cause the pump's impeller to swell and possibly bind up.

If bowl does not pump out and begins to fill, partially close inlet valve until bowl is cleared and completely pumped out. Then operate for a few seconds with both valves open to clear entire toilet and discharge system. For maximum safety, when toilet is not in use or vessel is unattended, close both the inlet and discharge seacocks.

To drain for winter layup, close inlet valve and operate for a few seconds until all water is pumped out.

DISASSEMBLY

Disconnect pump inlet and discharge hoses. Remove four screws, Key No. 23, pull out complete motor, pump and

⚠ WARNING



Flood hazard. Close inlet and outlet seacocks prior to disassembling toilet. Failure to do so can result in flooding which can cause loss of property and life.

macerator assembly. Remove macerator housing from base.

Remove discharge port, Key No. 9, and inspect joker valve. Unscrew chopper plate lock nut, Key No. 12, by

EXPLODED VIEW

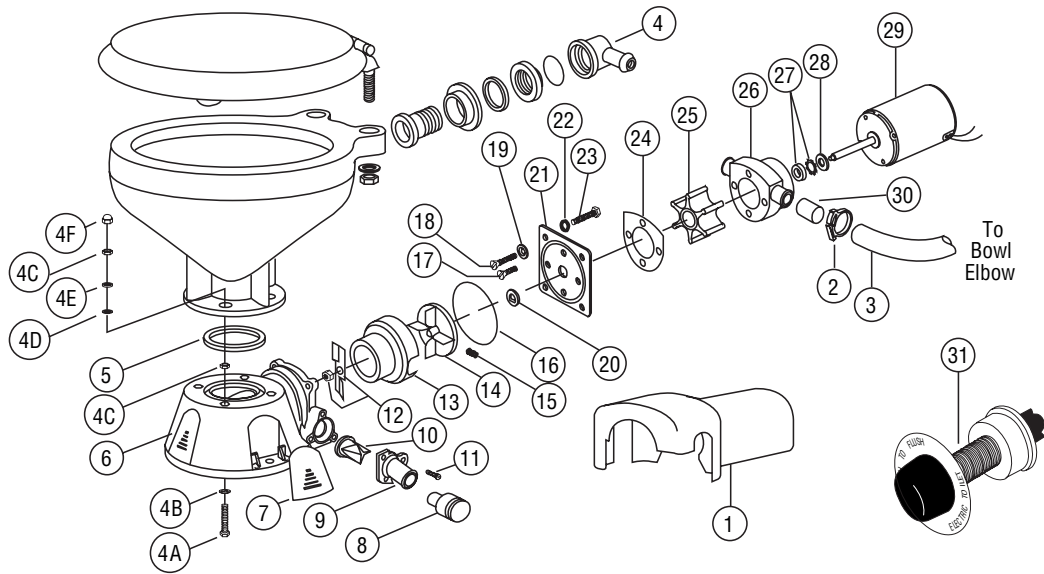

PARTS LIST

Key	Description	Qty. Req.	Part Number	Key	Description	Qty. Req.	Part Number
1	Motor Cover†	1	43990-0051	21	Wearplate ‡	1	37018-0000
2	Clamp	1	18753-0044	22	Lock Washer #10, Stainless Kit †	4	
3	Hose	1	29035-0001	23	Screw †	4	91027-0011
4	Bowl Installation Hardware	1	18753-0637	24	Gasket*†	1	12558-0000
4A	Hex Head Screw**	4		25	Flexible Impeller*†	1	6303-0003
4B	Starlock Washer**	4		26	Body †	1	12554-0000
4C	Hex Nut (two places)**	8		27	Seal & Retainer*†	1	1040-0000
4D	Washer, Plastic**	4		28	Slinger †	1	6342-0000
4E	Washer, Stainless Steel**			29	Motors:		
4F	Nut Cap**	4			Motor - 12 Volt EMC †	1	37064-0000
5	O-Ring	1	44101-1000		Motor - 24 Volt EMC †	1	37065-0000
6	Base Assembly**	1	37004-1000	30	Adaptor	2	93003-0240
7	Screw Covers (3/kit)	1	37003-0000	31	Switch & Plate	1	37020-0000
8	1-1/2" Adaptor, Discharge Port	1	98023-0080		Service Kit		37040-0000
9	1" Discharge Port**	1	44107-1000		Motor/Pump Assy. 12V EMC †		37041-0010
10	Joker Valve* **	1	44106-1000		Motor/Pump Assy. 24V EMC †		37041-0011
11	Screw**	3	96050-0568				
12	Chopper Plate† with Lock Nut	1	37056-1000				
13	Macerator Housing †	1	37014-0000				
14	Centrifugal Impeller †	1	37006-0000				
15	Set Screw †	1	18753-0492				
16	O-ring*†	1	43990-0066				
17	Screw Short †	2	91009-0096				
18	Screw Long †	2	91010-0130				
19	Washer, Plastic*†	2	35445-0000				
20	Sealing Sleeve †	1	37036-1000				

‡ Wearplate #21 includes Shaft Sealing Sleeve #20 and Pump/Base O-ring #16.

† Parts included in Motor-Pump Assembly.

turning counterclockwise, facing plate and remove chopper. Prevent shaft from turning by inserting a screwdriver in slot of shaft protruding from rear of motor. Loosen centrifugal impeller set screw and slide impeller off motor shaft.

Remove four flathead screws, Keys No. 17 & 18, wearplate, Key No. 21, shaft sealing sleeve, Key No. 20,

gasket, Key No. 24; then slide pump assembly off motor shaft. Replace all worn or damaged parts, clean remaining parts.

DIAGRAM 1

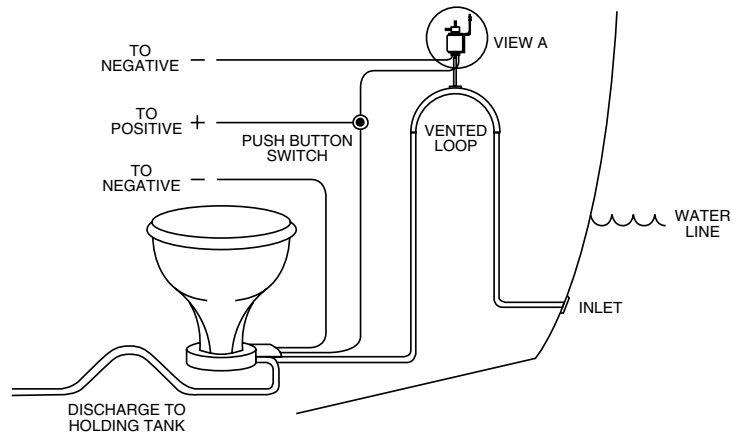
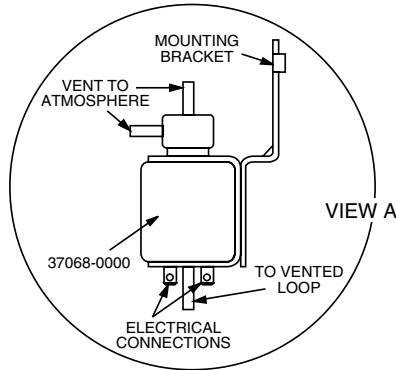

REASSEMBLY INSTRUCTIONS

Press seal into body with lip facing impeller; be careful not to cock seal in bore. Install pump body on motor and position on register; lubricate impeller bore with pump grease. Install impeller, gasket and wearplate. Make sure gasket surfaces are clean and smooth. Tighten wearplate screws. Slide shaft sealing sleeve onto shaft and seat in its bore in wearplate. Relocate centrifugal

impeller about 1/8" from wearplate and secure with set screw. Position macerator housing around centrifugal impeller then put chopper plate on end of shaft and secure with lock nut. Install O-ring in O-ring groove in wearplate surface (a little grease will help hold in place). Aligning key on top of macerator housing with slot in base, slide macerator assembly into base. Secure pump assembly with the four screws.

DIMENSIONAL DRAWING

Inches (Millimeters)

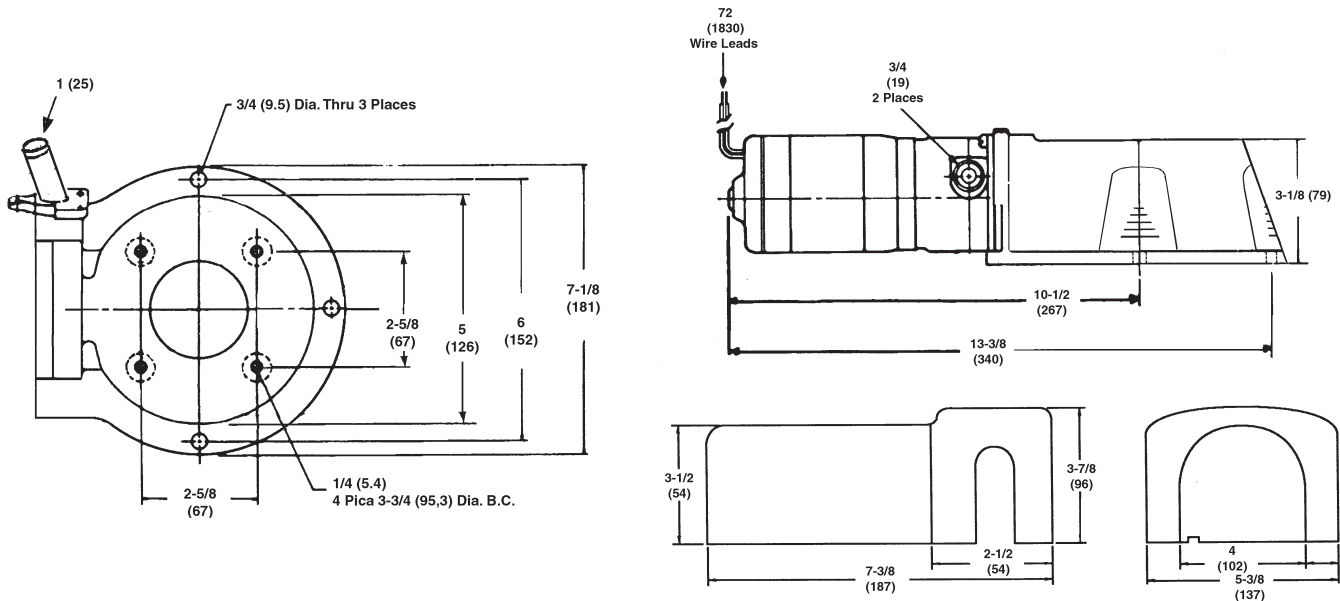

MOTOR COVER

Jabsco



U.S.A.
Jabsco
Cape Ann Industrial Park
Gloucester, MA 01930
Tel: 978.281.0440
Fax: 978.283.2619

UNITED KINGDOM
Jabsco
Bingley Road, Hoddesdon
Hertfordshire EN11 OBU
Tel: +44 (0) 1992 450145
Fax: +44 (0) 1992 467132

CANADA
Fluid Products Canada
55 Royal Road
Guelph, Ontario N1H 1T1
Tel: (519) 821.1900
Fax: (519) 821.2569

JAPAN
NHK Jabsco Company Ltd.
3-21-10, Shin-Yokohama
Kohoku-Ku, Yokohama, 222
Tel: 045.475.8906
Fax: 045.475.8908

GERMANY
Jabsco GmbH
Oststrasse 28
22840 Norderstedt
Tel: +49-40-53 43 73 -0
Fax: +49-40-53 53 73 -11

THE PRODUCTS DESCRIBED HEREIN ARE SUBJECT TO THE JABSCO ONE YEAR LIMITED WARRANTY, WHICH IS AVAILABLE FOR YOUR INSPECTION UPON REQUEST.