

MODEL: 37010-0002

INSTALLATION, OPERATION & SERVICE INSTRUCTIONS

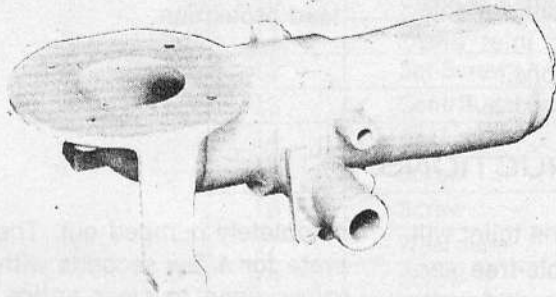

Model: 37010-0002

FEATURES

- Simple Push Button Operation
- Bronze Base
- Flexible Impeller Flush Pump
- High Capacity Macerator and Bowl Scavenger Pump
- All Corrosion Resistant Materials for Marine Use

SPECIFICATIONS

- $\frac{5}{8}$ " or $\frac{3}{4}$ " Inlet, 1" Outlet
- Back Flow Check in Discharge
- 12 Volt DC, 18 Amps
- Thru Flow Approximately $1\frac{1}{2}$ Quart per 5 Seconds of Operation

INSTALLATION INSTRUCTIONS

The PAR electric conversion kit may be installed above or below the waterline. Flush pump is self-priming up to 6 feet, discharge macerator pump can operate up to 4 foot head.

The PAR 37010-0002 can be used to convert the Raritan PH or Compact, Wilcox-Crittenden "Head Mate," Groco HC, Brydon #9127 or 9128 and virtually any other model marine toilet using the "standard" bowl configuration with a $3\frac{1}{4}$ " diameter bolt circle, 4 hole pattern in the base. Check the dimensional drawing to be sure the bowl will fit the flange dimensions as shown.

The PAR 37010-0002 includes the complete motorized base assem-

bly, bowl gasket, four bolts and washers for bowl, two $\frac{5}{8}$ " to $\frac{3}{4}$ " pump port adaptors and $\frac{5}{8}$ " hose elbow for rear bowl connection.

Other parts needed to complete the installation are available in the PAR Installation Kit No. 37022-0000. This kit includes all necessary hoses, clamps, adaptors and mounting bolts.

To complete your PAR electric toilet conversion, follow these installation suggestions:

1. Overall height after conversion may increase up to 1" on some models, check to be sure adequate space is available if located under seats or bunks.

2. Remove complete manual base assembly and mount bowl on PAR motorized base. NOTE: $1\frac{1}{4}$ " long bolts supplied are suitable for most bowls, however, some bowl flanges are heavier and $1\frac{1}{2}$ " long bolts must be used (these are included in the 37022-0000 installation kit). Plastic washers against bowl flange, position base for most convenient hose connection arrangement and accessibility of motor for serviceability.
3. Connect pump outlet to rear bowl connection with $\frac{3}{4}$ " hose, use plastic elbow and port sleeve adaptor supplied.
4. Position complete toilet assembly and fasten all four mounting feet securely on flat surface.

See dimensional drawing on back page for mounting & outline dimensions.

JABSCO PRODUCTS **ITT**

INSTALLATION INSTRUCTIONS

(Continued)

5. Connect existing inlet hose to pump inlet port. A $\frac{5}{8}$ " to $\frac{3}{4}$ " sleeve adaptor is included for fitting to commonly used $\frac{3}{4}$ " inlet hose size. Make sure all connections are airtight and free of sharp bends or restrictions.
6. Connect 1" hose to discharge port and make suitable connection to holding tank or other discharge system. Use 1" minimum hose and avoid sharp bends or restrictions.
7. For installation below waterline be sure to have a vented loop inlet hose about 8 inches above waterline at all angles of trim. Vented loop should also be used for discharge if connected to thru-hull.
8. For installations above waterline make a loop in discharge line about 8 inches above base of bowl to retain water in bowl.
9. If thru-hull seacocks cannot be conveniently operated from toilet location, install suitable shut-off valves for inlet and discharge connections.

WIRING HOOKUP. Use heavy duty stranded copper wire, #12 gauge for less than 10 feet and #10 gauge up to 15 feet in length. PAR switch assembly #37020-0000 with push button switch and fuse is suggested to complete the electrical installation. If other switch is used, be sure it has adequate amperage capacity and use 25 amp. fuse for overload protection.

OPERATING INSTRUCTIONS

Make sure inlet and outlet seacocks or valves are all open, push button to operate. If anti-syphon loops are used, hold fingertip over inlet vent for initial priming. Operate until bowl is completely flushed and discharge pump has scavenged water from bottom of bowl.

The PAR electric marine toilet will provide years of trouble-free service if properly used. It will handle waste and toilet tissue. It will NOT handle rags, sanitary napkins or hard solid objects.

If bowl does not pump out and begins to fill, partially close inlet valve until bowl is cleared and

completely pumped out. Then operate for a few seconds with both valves open to clear entire toilet and discharge system. After each operation close both the inlet and outlet seacocks or valves.

To drain for winter layup, close inlet valve and operate for a few seconds until all water is pumped out.

SERVICE INSTRUCTIONS

EXPLODED VIEW

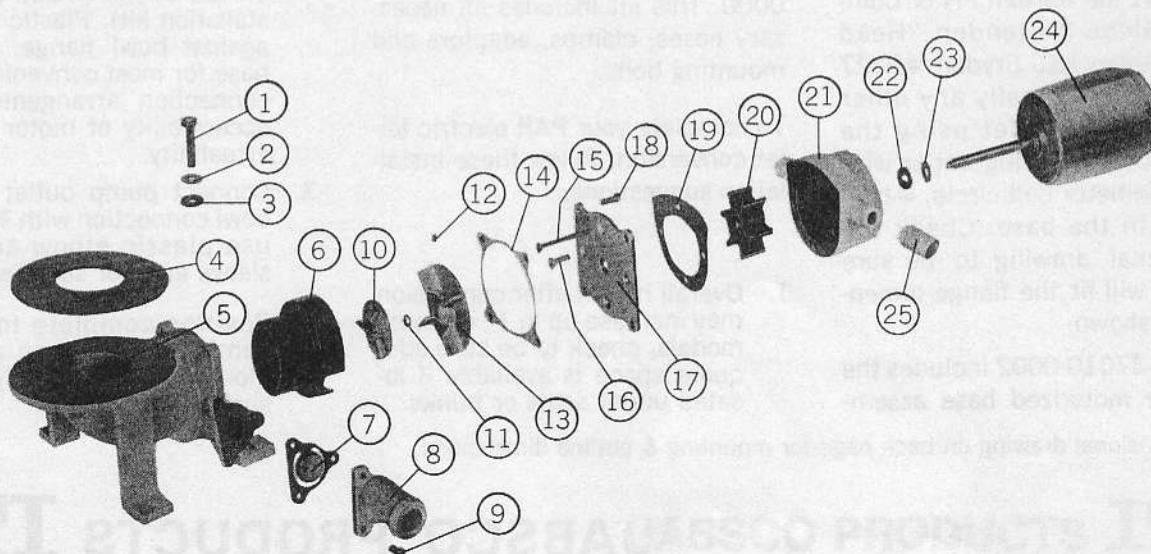

PARTS LIST

KEY	DESCRIPTION	PART NUMBER	QTY. REQ'D
1	Hex Head Screw	91095-1010	4
2	Washer, St. St'l	91603-0010	4
3	Washer, Plastic	50000-0707	4
4	Gasket	37017-0000	1
5	Base	37004-0000	1
6	Macerator Housing	37014-0000	1
7	Flapper Valve	37009-0000	1
8	Discharge Port	37015-0000	1
9	Screw	91002-0030	3
10	Chopper Plate	17266-0000	1
11	Washer	91602-0240	1
12	Set Screw	91084-0320	1
13	Centrifugal Impeller	37006-0000	1
14	Gasket	31019-0000	1
15	Screw	91010-0130	2
16	Screw	91009-0040	2
17	Wearplate	37018-0000	1
18	Screw	91003-0230	4
19	Gasket	12558-0000	1
20	Flexible Impeller	6303-0003	1
21	Body	12554-0000	1
22	Seal	92700-0910	1
23	Slinger	6342-0000	1
24	Motor	93004-2460	1
25	Adapter	93003-0240	2

DISASSEMBLY INSTRUCTIONS

Disconnect Pump inlet, outlet and discharge hoses. Remove four screws, Key #18, pull out complete motor, pump and macerator assembly. If assembly does not slide out easily, push forward and pull back sharply several times to free macerator housing from base.

Remove discharge port, Key #8, and check valve. Unscrew chopper plate, Key #10, by turning counterclockwise, facing plate. Prevent shaft from turning by placing screwdriver in discharge port and locking centrifugal impeller blade. Remove macerator housing. Mark location of centrifugal impeller on shaft. Loosen impeller set screw and slide impeller off motor shaft.

Remove four flathead screws, Key #15 & 16, wearplate, Key #17, gasket, Key #19. Slide pump assembly off motor shaft. Replace all worn or damaged parts, clean remaining parts.

REASSEMBLY INSTRUCTIONS

Press seal into body with lip facing impeller, be careful not to cock seal in bore. Install pump body on motor and position on register, lubricate impeller bore with pump grease. Install impeller, gasket and wearplate. Make sure gasket surfaces are clean and smooth. Tighten wearplate screws. Relocate centrifugal impeller in same position on shaft and tighten set screw. It is important that the impeller be exactly in the same position, otherwise, it will be jammed when motor assembly is installed on body. Impeller should have .010" space between wearplate and rear surface of impeller. Place macerator housing over shaft and impeller, put lock washer on end of shaft and screw chopper plate on shaft and tighten. Install gasket on wearplate surface, a little grease will help hold in place, make sure inside body surfaces are clean, line up slot in body with key on macerator housing, slide assembly into body and tighten with the four screws. Turn motor on for one or two seconds to be sure centrifugal impeller is free.

DIMENSIONAL DRAWING

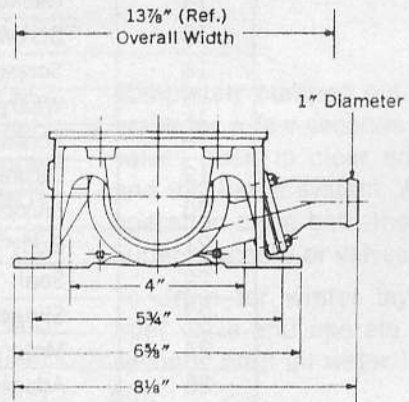
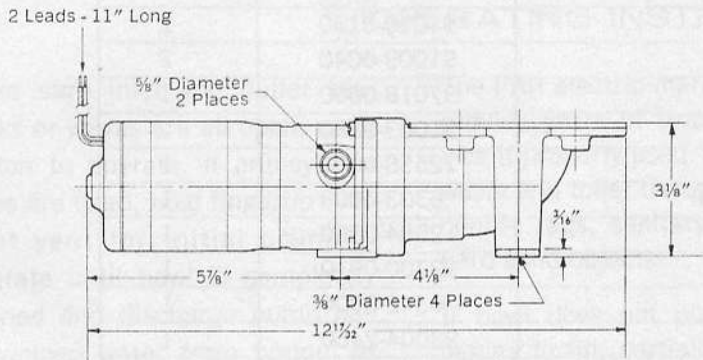
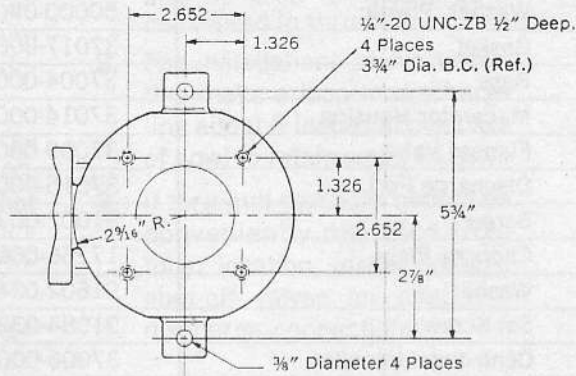

JABSCO PRODUCTS **ITT**

A Unit of International Telephone and Telegraph Corporation • 1485 Dale Way, Costa Mesa, California 92626

(714) 545-8251