

**PAR™**

**ELECTRIC WATER SYSTEM PUMPS**

**MODEL: 36975-1001  
36975-1011  
36975-1021**

**AUTOMATIC MULTI-FIXTURE**

**PRODUCT DATA**

**FEATURES**

- Self-Priming
- Diaphragm Design Allows Dry Running
- Built-in Discharge Check Valve
- Low Current Draw
- Built-in Hydraulic Pulsation Dampener
- Large Vibration Absorbing Pads
- Threaded and Flare Ports Available
- BIA Type Accepted
- Meets USCG Electrical Regulation Title 33, Chapter I, Section 183.410
- IAPMO Approved (12 VDC)

**SPECIFICATIONS**

	U.S. GPM	Liters/min.	Imp. GPM
Open Flow:	2.9	11.0	2.4
Cut-in Pressure:	18 PSI Nom. (120 kPa)		
Cut-off Pressure:	33 PSI Nom. (230 kPa)		
Ports:	Slip-on 1/2" or 5/8" ID Hose.		
Vert. Dry Suction Lift:	6 feet (1.8m)		
Approval:	IAPMO Type IV		
Shipping Weight:	6-1/2 Lbs. (3 kgs.)		

**CURRENT AND FUSE RATING**

MODEL	VOLTAGE	NOM. AMP DRAW	FUSE RATING	
			"SLO-BLO"	NORMAL
36975-1001	12 VDC	5.0	5 AMP	7½ AMP
36975-1011	24 VDC	3.0	4 AMP	5 AMP
36975-1021	32 VDC	2.0	2 AMP	3AMP

**MODEL 36975 SERIES  
AUTOMATIC MULTI-FIXTURE**

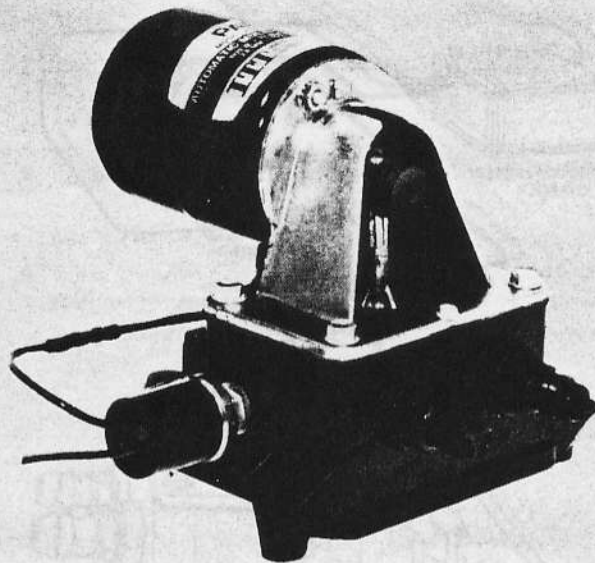

**APPLICATIONS**

PAR Automatic Water Systems, 36975 series, are designed for self contained recreational vehicles and pleasure boats with multiple fixture water systems. The systems are automatic – when a faucet is opened, the pump instantly begins operation to provide a constant flow from tank to faucet. Closing the faucet automatically discontinues pump operation.

**PUMP DIMENSIONS**

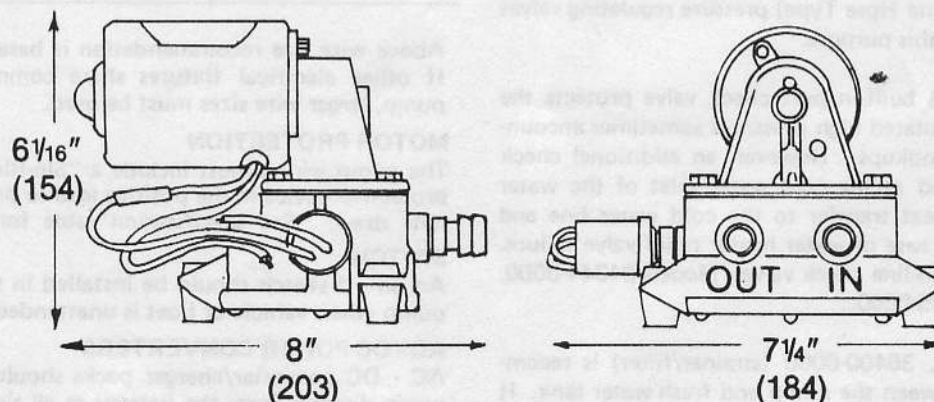

Dimensions in parenthesis are millimeters

**JABSCO PRODUCTS ITT**

Form 43000-0394 Rev. 8/80

# INSTALLATION

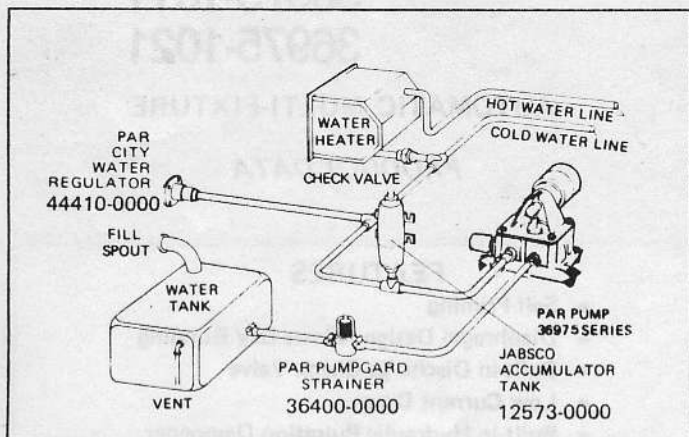

## MOUNTING

PAR diaphragm pumps are self-priming.

They may be located above, below or at some level as the fresh water tank. Suction lift should not exceed 5 feet, when positioned above the tank. The pump is equipped with vibration absorbing feet which are most effective when the pump is in the upright position.

## PLUMBING

To minimize water pressure drop, the size of water supply line from tank to pump should NOT be less than sizes shown in table below. Valves, elbows, etc. used should be the same size as pipe or tubing. Use gate valves only. Fresh water tank must be vented.

**MINIMUM PIPING SIZE**

Supply Line Length	Tubing I.D.	Pipe Size
Less Than 48"	1/2"	3/8"
48" or more	5/8"	1/2"

**PRESSURE REGULATOR.** It is recommend that systems having a connection for a city water entry be equipped with a pressure regulating check valve set at approximately 35 PSI. This valve automatically regulates the incoming water pressure to avoid damage to pump and plumbing from excessive pressures. PAR Models 44410-0000 (Permanent Flush Mount) and 44410-0010 (In-line Hose Type) pressure regulating valves are recommended for this purpose.

**CHECK VALVES.** A built-in port check valve protects the pump from the unregulated high pressures sometimes encountered in city water hookups. However, an additional check valve may be installed at the cold water inlet of the water heater to minimize heat transfer to the cold water line and protect the system in case of water heater relief valve failure. PAR offers qualified in-line check valves, Models 34344-0000, 35027-0000 and 35195-0000.

## SUCTION FILTER

A PAR Pumpgard No. 36400-0000 (strainer/filter) is recommended, installed between the pump and fresh water tank. It helps prevent valve clogging caused by foreign material entering the pump.

## WATER PURIFIER

Water purifiers should be installed with separate outlets for drinking water use only. Many purifiers cause excessive back pressure.

## ACCUMULATOR TANK

The use of an accumulator tank (Jabsco Model 12573-0000), although not required, is recommended for a more effective water distribution system. It eliminates "water hammer", stores pressure to allow a limited use of water without restarting pump (desirable at night-time), assures a constant even stream of water at faucets farthest from pump and stops rapid on-off cycling of pump during restricted flow.

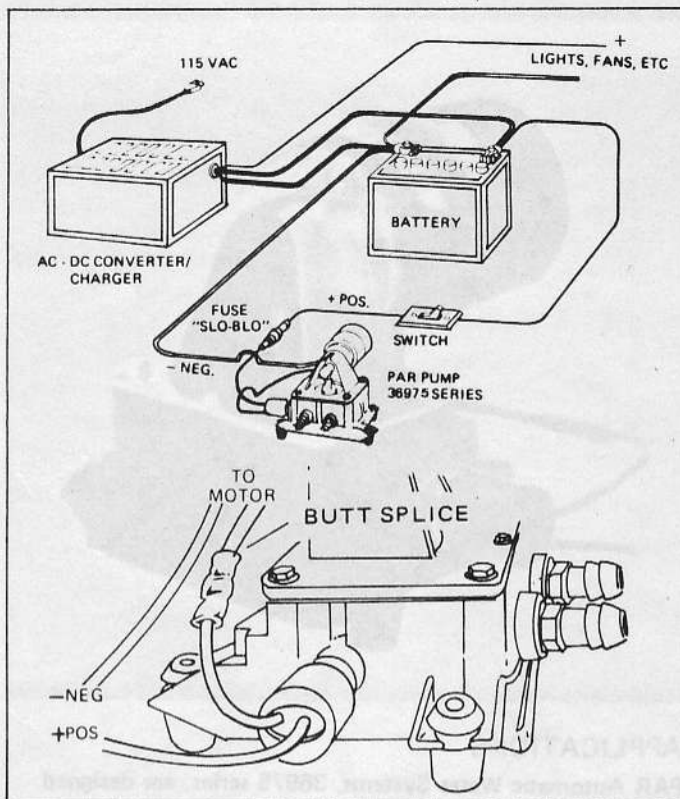

## WIRING

Pump should be wired in an independent circuit according to the following chart:

### WIRE SIZE CHART (A.W.G. - COPPER)

Length of circuit in feet (sum of + pos. & - neg. wire lengths)

Voltage	Up to 80'	80' to 100'	100' to 150'
12 Volts Two Wire	14	12	10
24 Volts Two Wire	16	14	14
32 Volts Two Wire	16	16	14

Above wire size recommendation is based on pump load only. If other electrical fixtures share common service with the pump, larger wire sizes must be used.

## MOTOR PROTECTION

The pump wiring must include a "Slo-Blo" fuse or equivalent protective device in the positive lead to protect against overcurrent draw. See specification table for proper fuse rating.

## SWITCH

An on-off switch should be installed in the circuit to turn off pump when vehicle or boat is unattended, stored, or in transit.

## AC - DC POWER CONVERTERS

AC - DC converter/charger packs should be wired to operate pump directly from the battery at all times. If the battery is bypassed and converter is used to service the pump directly, be sure the total electrical loads do not exceed the converter Amp rating.

## VOLTAGE CHECK

After installation, check the voltage at the pump motor leads. It is important that voltage is checked when pump is operating along with all the inside electrical fixtures. Full voltage must be available at the pump motor at all times.

## OPERATION

- Check level of water in tank.
- Check all strainers or any aerators and clean thoroughly
- Open all faucets, hot and cold.
- Turn on power to pump and wait for hot water tank and water lines to fill.
- Close each faucet when it starts to deliver a steady stream of water (close cold water faucet first.)
- Observe the pump. Check to be sure pump stops soon after closing last faucet.
- Pump is now ready for automatic operation. It will start when a faucet is opened and stop when the faucet is closed.
- Turn off power to pump and open a faucet momentarily to relieve system pressure before hooking up to city water.
- Turn off power to pump and open faucet when leaving RV or boat unattended for extended periods. Use enclosed label as a reminder at pump power switch.

## MAINTENANCE WINTER STORAGE

**WINTER STORAGE.** PAR pumps, with their unique pulsation dampener, will withstand frozen water without damage, provided the system is not under pressure prior to freezing. To prevent accidental damage, the entire water system should be protected from freezing during winter storage. This requires complete draining, using the following directions and/or vehicle manufacturers instructions:

1. Open all faucets and drains and allow pump to empty water tank and intake line. Run the pump dry for 1 to 2 minutes before turning off.
2. With all drains open, blow air through city water entry. Allow time for the water heater to empty.
3. Disconnect discharge and intake hoses from the pump. Start the pump and allow to run until all water is expelled from unit. (Running dry will not harm the pump.)
4. Reconnect the hoses, close the drains but leave faucets open. The water distribution system is now dry and ready for winter storage.

An alternate method is to use potable water system anti-freeze solution. Follow directions of anti-freeze manufacturer, and use a PAR Winter Protection Kit Model 44610-0000. **DO NOT USE AUTOMOTIVE TYPE RADIATOR ANTI-FREEZE. IT IS POISONOUS.**

## SERVICE

### TROUBLE SHOOTING

Problems	Causes
1. Pump operates but no water flows through faucet.	<ul style="list-style-type: none"><li>- Low water level in tank.</li><li>- Suction line clogged or kinked.</li><li>- Loose hose clamps or fittings in suction line.</li><li>- Dirty or hard-to-open in-line check valve.</li><li>- Defective pump check valve.</li></ul>
2. Pump cycles on and off although all faucets are closed.	<ul style="list-style-type: none"><li>- Water leak in plumbing.</li><li>- Water leak in flush toilets.</li><li>- Internal leak in pump.</li><li>- Outlet valve not sealing.</li></ul>
3. Pump operates roughly and has excessive noise and vibration.	<ul style="list-style-type: none"><li>- Flow through intake line is restricted, kink in hose.</li><li>- Pump mounted on flimsy board.</li><li>- Deformed or ruptured pulsation dampener in pump.</li><li>- Worn connecting rod bearing.</li></ul>
4. Pump fails to start when faucet is opened.	<ul style="list-style-type: none"><li>- No voltage to pump.</li><li>- Blown fuse.</li><li>- Clogged piping.</li><li>- Kink in outlet line.</li><li>- Defective pressure switch.</li></ul>
5. Pump fails to stop when faucets are closed.	<ul style="list-style-type: none"><li>- Empty water tank.</li><li>- Outlet valve not sealing.</li><li>- Air in system.</li><li>- Very low voltage.</li><li>- Defective pressure switch.</li></ul>

**CAUTION:** Before servicing pump, turn off power and open faucets to relieve pressure in water system.

### VALVE FLAPPER REPLACEMENT

1. Remove motor and six tie down screws. (see Motor Replacement)
2. Lift off motor mount and diaphragm assembly from the pump base.
3. Remove bottom plate and pulsation dampener.
4. Pull valve flappers from base and clean all foreign materials from seats.
5. Install new valve flappers into base, wet, intake from top and output from bottom. Note that both flippers are the same and interchangeable.

### DIAPHRAGM AND CONNECTING ROD REPLACEMENT

1. Remove motor and six tie down screws. (see Motor Replacement)
2. Lift off motor mount and diaphragm assembly from the pump base.
3. Remove diaphragm screw to separate diaphragm from connecting rod assembly.
4. Inspect diaphragm for cuts and cracks.
5. Check connecting rod assembly for breaks, cracks or excessive wear on eccentric rod and bearing if connecting rod is to be reused, open cover and relubricate by packing built-in reservoir with an automotive grease. Original lubricant normally lasts the lifetime of the pump.
6. When reassembling connecting rod to diaphragm, be sure to align. Proper alignment is achieved when the rod slips straight onto motor shaft and the diaphragm rests squarely on the motor mount pad. Misalignment will create a strain on diaphragm and significantly shorten its life

EXPLODED VIEW

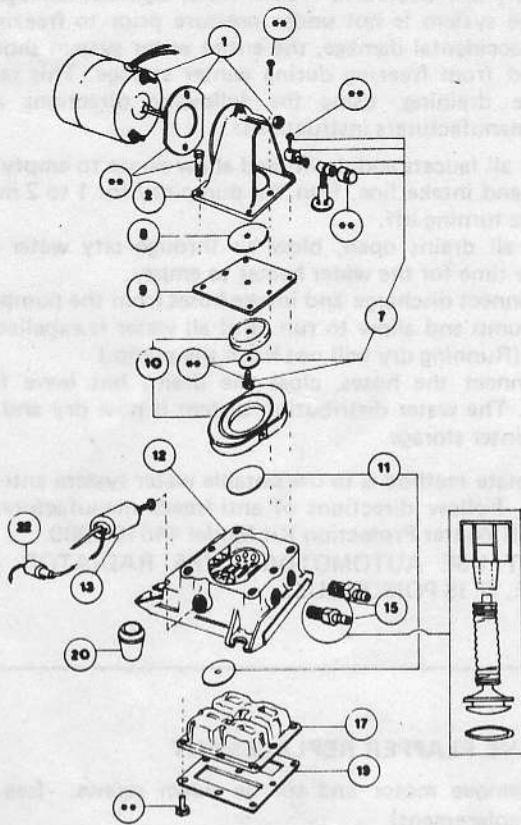

\*\*Indicates items included in Hardware Kit (Key 21).

PARTS LIST

Key	Description	Part Number	Qty.
1	Motor Kit 12 Volt D.C. 24 Volt D.C. 32 Volt D.C.	30201-0000 30201-0010 30202-0020	1
2	Motor Mount	35452-0001	1
7	*Connecting Rod Assembly	30033-0000	1
8	Diaphragm Plate	35479-0000	1
9	*Diaphragm	44821-0000	1
10	Spacer Set	44822-0000	1 Set
11	*†Valve Flappers (Inlet & Outlet)	44823-0000	1 Set
12	†Base Assembly	44824-0000	1
13	Pressure Switch	44814-0000	1
15	Ports (Inlet & Outlet) Barb (See Note)	37176-0000	1 Set
17	*†Pulsation Dampener	44825-0001	1
19	†Bottom Plate	35686-0000	1
20	†Vibration Pad Kit	44826-0000	1 Set
21	Hardware Kit *Service Kit	44827-0000 44829-0001	1 Set 1 Set

\*Indicates Parts Contained in Service Kit.

†Indicates Parts Supplied with Base Assembly.

**NOTE:** Threaded Outlet Port 37050-0001  
Threaded Inlet Port 37050-0000  
Flare Outlet Port 37050-0002  
Flare Inlet Port 37050-0003

SERVICE (CONTINUED)

PULSATION DAMPENER REPLACEMENT

1. Remove pump from installation.
2. Remove nine screws from bottom of base and the bottom plate.
3. Pull out rubber pulsation dampener from base.
4. Inspect dampener for excessive deformation, ruptures and leaks.
5. When installing new pulsation dampener, make sure flange is correctly seated to effect a proper water and air seal.

PRESSURE SWITCH REPLACEMENT

1. Disconnect wires from pressure switch leads.
2. Unscrew switch from base.
3. Thread switch with sealing washer into pump base, metallic side of washer facing switch. Tighten securely.
4. Rewire one lead to motor, other to fused positive circuit

BASE REPLACEMENT

1. Follow service instructions above to remove pressure switch and pulsation dampener.
2. To separate base from motor mount and diaphragm assembly, remove all motor mount screws.
3. When reassembling, do not overtighten screws.

MOTOR REPLACEMENT

1. Disconnect one motor wire from pressure switch lead, the other from splice connector of negative circuit.
2. Loosen eccentric set-screw on motor shaft.
3. Remove two motor nuts and pull motor away from motor mount, while holding back eccentric/connecting rod assembly.
4. When installing new motor, adjust eccentric on motor shaft so little or no contact is made between teflon washer and connecting rod bearing while running.
5. Rewire motor leads to one pressure switch lead and negative circuit.



JABSCO PRODUCTS **ITT**

Marine and Recreation Components Division  
International Telephone and Telegraph Corporation  
1485 Dale Way, Costa Mesa, California 92626

Phone 714/545-8251