

PAR

Model 36950-SERIES

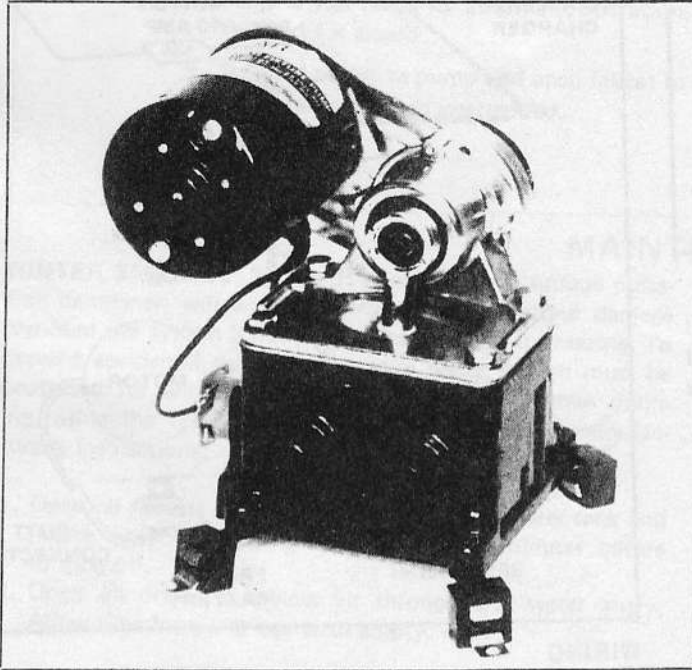

ELECTRIC WATER SYSTEM PUMP

Automatic Multi-Fixture

FEATURES

- Self-Priming
- Diaphragm Design Allows Dry Running
- Built-in Discharge Check Valve
- Quiet Operation
- Built-in Hydraulic Pulsation Dampener
- Large Vibration Absorbing Pads
- Ports Available with Barb, Threads or Flare
- Meets USCG Electrical Standards
- IAPMO Listed

SPECIFICATIONS

	U.S. GPM	litres/min	Imp. GPM
Open Flow:	3.0	11,3	2.5
Cut-in Pressure (Nom):	18 ± 4 PSI (120 kPa)		
Cut-off Pressure (Nom):	39 ± 4 PSI (269 kPa)		

Vert. Dry Suction Lift: 5 Feet (1,5m)

Ports: Slip-on 1/2" or 5/8" ID Hose

Approx. Ship. Weight: 11 lbs 5,0 kgs

Listing: IAPMO Type IV

APPLICATIONS

PAR automatic water system pumps are designed for self contained recreational vehicles and pleasure boats with multiple-fixture water systems. The systems are automatic — when a faucet is opened, the pump instantly begins operation to provide a constant flow from tank to faucet. Closing the faucet automatically discontinues pump operation.

DIMENSIONAL DRAWING INCHES (MILLIMETRES)

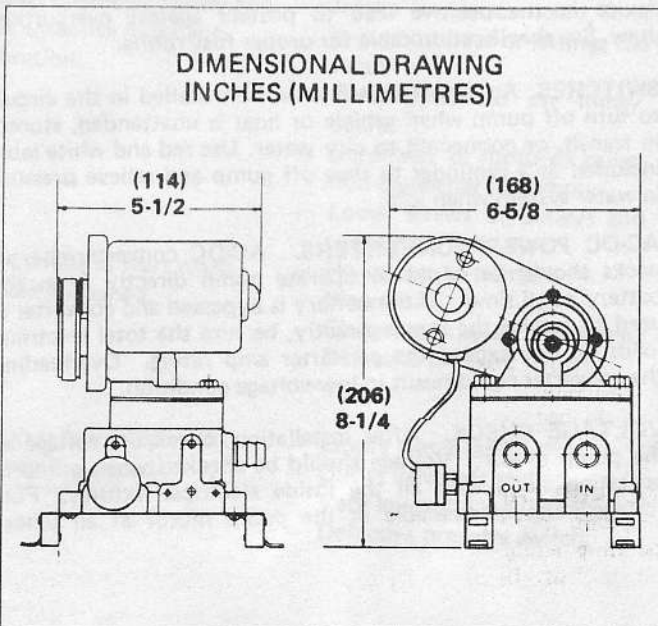

ELECTRICAL SPECIFICATIONS

MODEL	VOLTAGE	NOM. AMP DRAW	FUSE RATING	
			Slow-Blow	NORMAL
36950-1000	12 Vdc	6	6-1/4 Amp	8 Amp
36950-1010	24 Vdc	3	3 Amp	4 Amp
36950-1020	32 Vdc	2.2	2 Amp	3 Amp

*new model
36950-2000*

Model 36950-SERIES

INSTALLATION

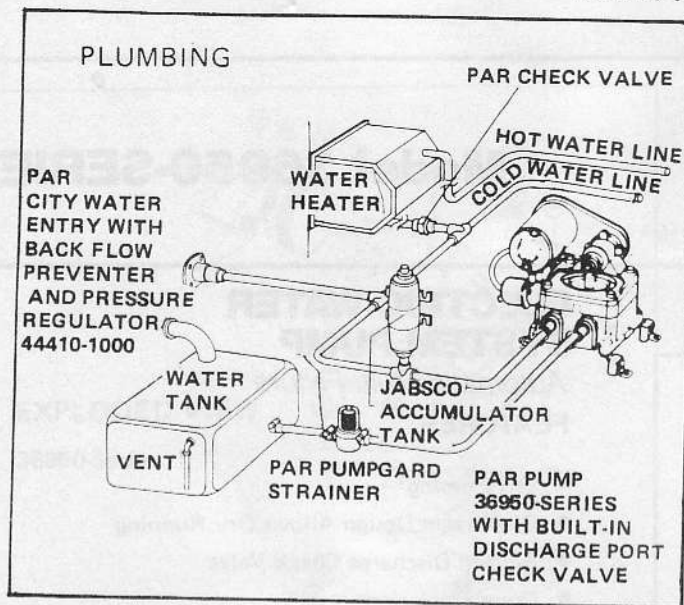

MOUNTING

PAR diaphragm pumps are self-priming. They may be located above or below the fresh water tank. The pump is equipped with vibration pads which are most effective when the pump is mounted upright on a solid surface.

PLUMBING

To minimize water pressure drop, the size of water supply line should not be less than sizes shown in the table below. Valves, elbows, etc. used should be the same size as pipe or tubing. Use full opening (gate or ball type) valves only. Fresh water tank must be vented.

MINIMUM PIPING SIZE

Supply Line Length	Hose ID	Pipe Size
Less than 48"	1/2"	3/8"
48" or more	5/8"	1/2"

PRESSURE REGULATOR. It is recommended that systems having a connection for city water be equipped with a pressure regulator set at approximately 35 psi. This valve automatically regulates the incoming water pressure to avoid damage to the pump and plumbing from excessive pressures. PAR Model 44410-1000 (permanent flush mount) and Model 44410-1010 (in-line) pressure regulating valves are recommended for this purpose.

SUCTION FILTER. A PAR Pumpguard Model 36400-0000 (strainer/filter) is recommended to be installed between the pump and fresh water tank. It helps prevent valve clogging caused by foreign material entering the pump.

WATER PURIFIER. Many water purifiers cause excessive restriction to flow, especially when element is in use for some time. When used at the main distribution line it causes the pump to cycle on and off rapidly. To minimize cycling, use an accumulator tank between pump and purifier, or install purifier to feed a single outlet for drinking-water only.

ACCUMULATOR TANK. The use of an accumulator tank (Jabco® Model 12573-2000 or 18810-0000), although not required, is recommended for a more effective water distribution system. It eliminates "water hammer," stores pressures to allow a limited use of water without restarting pump (desirable at night-time), assures a constant, even stream of water at faucets farthest from pump and prolongs pump life by cutting down rapid start/stop operation.

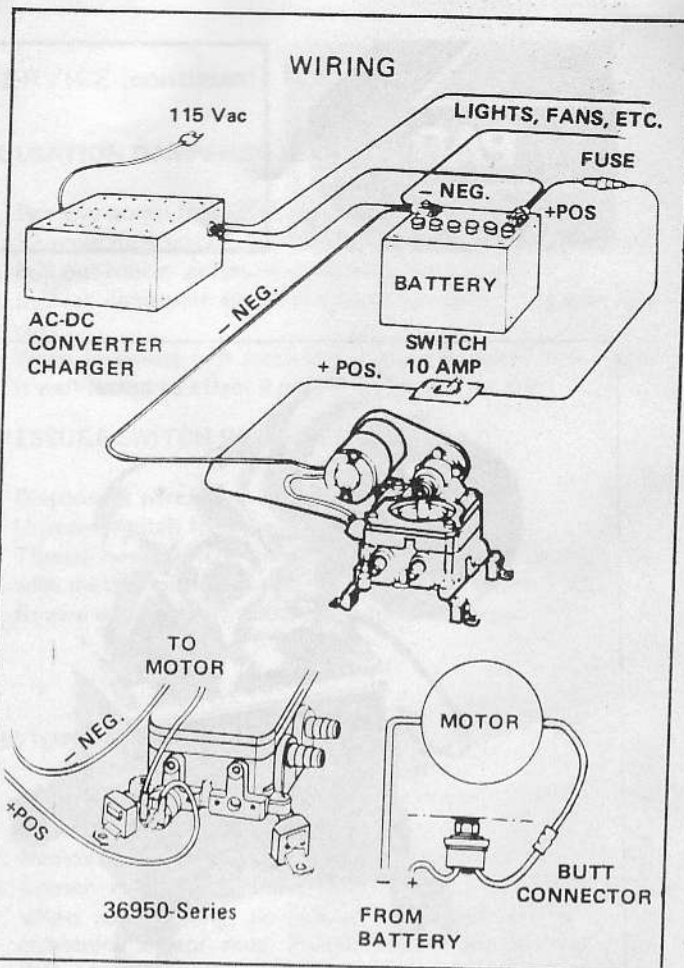

WIRING

Pump should be wired in an independent circuit according to the wiring diagram.

WIRE SIZE CHART (AWG-COPPER)

Length of circuit in feet (Sum of + Pos. & - Neg. Wire Lengths)

Voltage	Up to 80'	80' to 100'	100' to 150'
12 Volts	14	12	10
24 Volts	16	14	14
32 Volts	16	16	14

MOTOR PROTECTION.

The pump wiring must include a fuse or equal protective device in the positive lead to protect against overcurrent draw. See specification table for proper fuse rating.

SWITCHES. An on-off switch must be installed in the circuit to turn off pump when vehicle or boat is unattended, stored, in transit, or connected to city water. Use red and white label included as a reminder to shut off pump and relieve pressure in water system when idle.

AC-DC POWER CONVERTERS. AC-DC converter/charger packs should be wired to operate pump directly from the battery at all times. If the battery is bypassed and converter is used to service the pump directly, be sure the total electrical loads do not exceed the converter amp rating. Overloading the converter could result in low-voltage condition.

VOLTAGE CHECK. After installation, check the voltage at the pump motor. Voltage should be checked when pump is operating along with all the inside electrical fixtures. Full voltage must be available at the pump motor at all times.

OPERATION

- Check water level in tank. Be sure valves are open and strainers and aerator are clean.
- Open all faucets, hot and cold.
- Turn on power to pump.
- Close each faucet when it starts to deliver a steady stream of water (close cold water first).
- Observe the pump. Check to be sure pump stops soon after all faucets are closed.
- Pump is now ready for automatic operation. It will start when a faucet is opened and stop when the faucet is closed.
- Turn off power to pump and open faucet to relieve pressure in system *before* hooking up to city water and when *unattended*.

MAINTENANCE

WINTER STORAGE. The PAR pump, with its unique pulsation dampener, will withstand frozen water without damage provided the system is not under pressure prior to freezing. To prevent accidental damage, the entire water system must be protected for winter storage. This requires complete draining, using the following directions and/or vehicle manufacturer's instructions:

1. Open all faucets and allow pump to empty water tank and intake lines. Run pump dry for 1 to 2 minutes before turning off.
2. Open all drains and blow air through city water entry. Allow time for water heater to empty.

3. Disconnect discharge and intake hoses from pump. Start pump and allow to run until all water is expelled from unit. (Running dry will not harm the pump).
4. Reconnect the hoses, close the drains and leave faucets open. The water distribution system is now dry and ready for winter storage.

Use a PAR Winter Protection Kit, Model 44610-0000, to install winter protection fluid without disconnecting plumbing. **DANGER: DO NOT USE AUTOMOTIVE TYPE RADIATOR ANTI-FREEZE. IT IS POISONOUS. USE OF THIS TYPE OF ANTI-FREEZE WILL CAUSE SERIOUS INTERNAL INJURY OR DEATH.**

SERVICE

TROUBLESHOOTING

<u>Problem</u>	<u>Causes</u>
Pump operates but no water flows through faucet.	<ul style="list-style-type: none">— Low water level in tank.— Suction line clogged or kinked.— Air leak in suction line.— Loose hose clamps or fittings in suction line.
Pump cycles on and off when faucets are closed.	<ul style="list-style-type: none">— Water leak in plumbing.— Defective toilet flush valve.— Internal leak in pump.— Outlet valve not sealing.
Pump operates roughly and has excessive noise and vibration.	<ul style="list-style-type: none">— Intake line is restricted, kink in suction hose or fittings too small.— Pump mounted on flimsy board.— Deformed or ruptured pulsation dampener in pump.— Loose screws at pulleys and connecting rod.
Pump fails to start when faucet is opened.	<ul style="list-style-type: none">— No voltage to pump.— Blown fuse.— Clogged or kinked outlet line.— Defective pressure switch.
Pump fails to stop when faucets are closed.	<ul style="list-style-type: none">— Empty water tank.— Outlet valve not sealing.— Very low voltage to pump.— Defective pressure switch.

NOTICE: Before servicing pump, turn off power to pump and open faucets to relieve pressure in water system.

VALVES REPLACEMENT

1. Remove motor and four tie down screws.
2. Expose valves by lifting jack shaft and attached diaphragm assembly from pump base.
3. Lift valves from pockets. Clean all foreign materials from valves and seats.
4. Reinstall valves into same pockets, being sure rubber valve with small hole is UP on intake and rubber valve without the small hole is DOWN on discharge (see exploded view). **NOTE: Do not use valve with small hole in rubber on discharge side of pump.**
5. When reassembling, adjust belt tension to 1/4" play.

DIAPHRAGM & CONNECTING ROD REPLACEMENT

1. Remove motor and four tie down screws then lift jack shaft and attached diaphragm assembly from pump base.
2. Expose diaphragm by removing two diaphragm ring screws and detaching ring.
3. Remove diaphragm screw to separate diaphragm and plates from connecting rod. Inspect diaphragm for cuts and ruptures.
4. Remove eccentric screw to separate connecting rod from jack shaft.
5. When reassembling, be sure to align diaphragm and connecting rod so that rod slips straight onto jack shaft and diaphragm rests squarely on diaphragm retainer. Misalignment will create a strain on diaphragm and significantly shorten its life. Adjust belt tension to 1/4" play.

SERVICE (continued)

PULSATION DAMPENER REPLACEMENT

1. Remove pump from installation.
2. Remove nine screws from bottom of base and bottom plate.
3. Pull out rubber pulsation dampener from base.
4. Inspect dampener for excessive deformation, ruptures and cuts.
5. When installing new pulsation dampener, make sure flange is well-seated to effect a proper water and air seal.

PRESSURE SWITCH REPLACEMENT

1. Disconnect wires from pressure switch.
2. Unscrew switch from base.
3. Thread new switch with sealing washer into pump base, with metallic side of washer facing switch. Tighten securely.
4. Rewire one lead to motor, other to fused circuit.

MOTOR REPLACEMENT

1. Disconnect one motor wire from pressure switch terminal, the other from splice connector.
2. Remove two motor nuts to separate motor.
3. Loosen screw to slide off small pulley from motor shaft.
4. When reassembling, be sure to adjust belt tension before tightening motor nuts. Proper adjustment is made when belt can be depressed 1/4" at a point halfway between pulleys. Do not over tighten belt.

THE PRODUCT DESCRIBED HEREIN IS SUBJECT TO THE JABSCO ONE YEAR LIMITED WARRANTY, WHICH IS AVAILABLE FOR YOUR INSPECTION UPON REQUEST.

** New Base Assy. 44114-1100
for new type switch + a adapter for same*

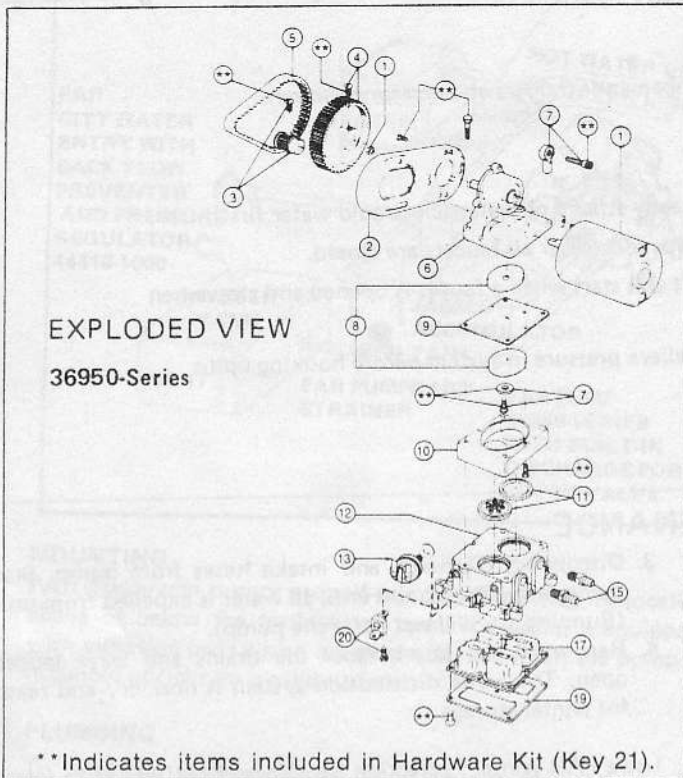

PARTS LIST

36950 - Series

Key	Part Description	Part Number	Qty
1	Motor Kit 12 Vdc.	30200-0000	1
1	Motor Kit 24 Vdc.	30200-0010	
1	Motor Kit 32 Vdc.	30200-0020	
2	Motor Mount	34628-0000	1
3	Small Pulley	37169-0000	1
4	Large Pulley	37171-0000	1
5	Belt	30022-0000*	1
6	Jack Shaft Assembly	35689-0000	1
7	Connecting Rod Assembly	37173-0000	1
8	Diaphragm Plate	35503-0000	2
9	Diaphragm	30015-0000*	1
10	Retainer	35497-0000	1
11	Valve Set (Inlet & Outlet)	30004-0000*†	1 Set
12	Base Assembly†	35620-1100†	1
13	Pressure Switch	37121-0010—See Note 3 44814-0001—See Note 2	1
15	Ports(Inlet & Outlet) Barb	37176-0000†— See Note 4	1 Set
17	Pulsation Dampener	37178-0000*†	1
19	Bottom Plate	35686-0000†	1
20	Vibration Pad Kit	37180-0000†	1 Set
21	Hardware Kit	37166-0000	1 Set
	Service Kit*	30126-0000	

*Indicates Parts Contained in Service Kit.

†Indicates Parts Supplied with Base Assembly.

NOTE 2— Includes Switch and Conversion Kit to Mount New Style Switch Onto Older Style-J and -0000 Pumps.

NOTE 3— Replacement Switch only for -1000 Series Pumps. Meets USCG Electrical Standards.

NOTE 4— Threaded Outlet Port 37050-0001
Threaded Inlet Port 37050-0000
Flare Outlet Port 37050-0002
Flare Inlet Port 37050-0003