

Model 36950-2 Series

ELECTRIC WATER SYSTEM PUMP *Automatic Multi-Outlet*

FEATURES

- Self-Priming
- Diaphragm Design Allows Dry Running
- Built-in Discharge Check Valve
- Quiet Operation
- Built-in Hydraulic Pulsation Dampener
- Large Vibration Absorbing Pads
- Ports Available with Barb, Threads or Flare
- Meets USCG Regulation 183.410 and ISO 8846 MARINE for Ignition Protection



Model 36950-2 Series

SPECIFICATIONS

	U.S. GPM	litres/min.	Imp. GPM
Open Flow:	3.0	11,3	2.5
Vert. Dry Suction Lift:	5 Feet	(1,5m)	
Ports:	Slip-on 1/2" or 5/8" ID Hose		
Approx. Ship. Weight:	11 lb (5,0 kg)		

MODEL	VOLTS	NOM. AMP DRAW	PRESSURE		FUSE/BREAKER* NORMAL
			CUT-IN psi (bar)	CUT-OUT psi (bar)	
2000	12 Vdc	6	20(1.4)	40(2.7)	8 Amp
2010	24 Vdc	3	20(1.4)	40(2.7)	4 Amp
2200	12 Vdc	6	10(0.7)	20(1.4)	8 Amp
2210	24 Vdc	3	10(0.7)	20(1.4)	4 Amp

* Customer supplied, not included with pump.

APPLICATIONS

Jabco automatic water system pumps are designed for self contained recreational vehicles and pleasure boats with multiple-outlet water systems. The systems are automatic – when a faucet is opened, the pump instantly begins operation to provide a constant flow from tank to faucet. Closing the faucet automatically discontinues pump operation.

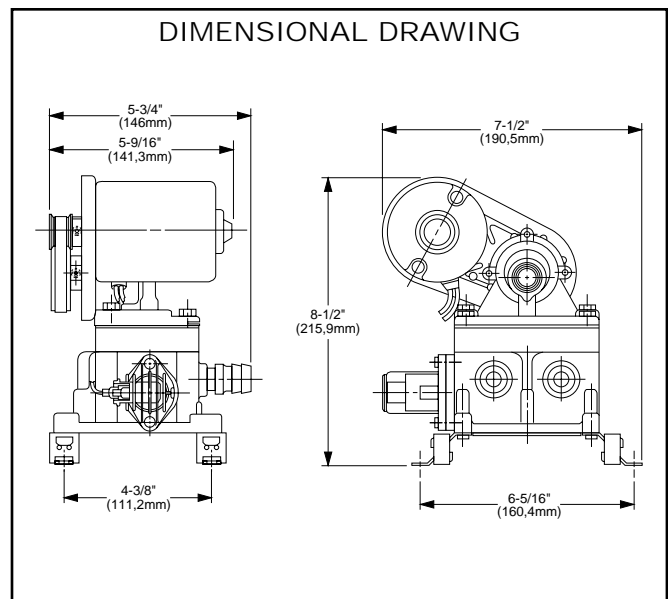

INSTALLATION

PLUMBING

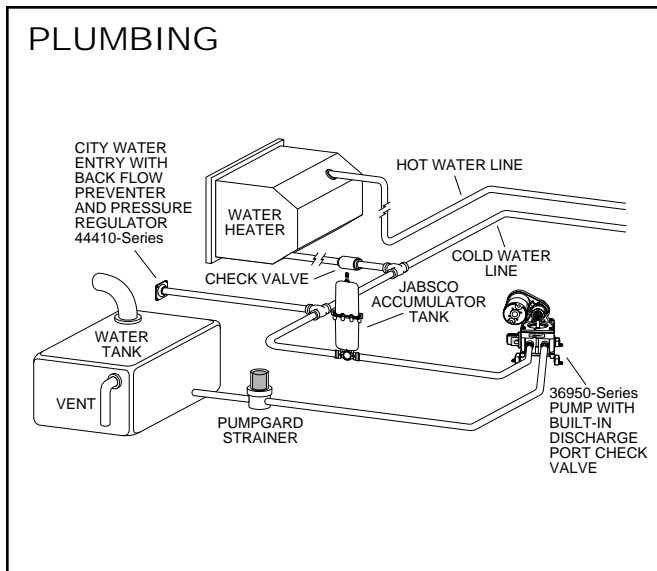

MOUNTING

Jabsco diaphragm pumps are self-priming. They may be located above or below the fresh water tank. The pump is equipped with vibration pads which are most effective when the pump is mounted upright on a solid surface.

PLUMBING

To minimize water pressure drop, the size of water supply line should not be less than sizes shown in the table below. Valves, elbows, etc. used should be the same size as pipe or tubing. Use full opening (gate or ball type) valves only. Fresh water tank must be vented.

MINIMUM PIPING SIZE		
Supply Line Length	Hose ID	Pipe Size
Less than 48"	1/2"	3/8"
48" or more	5/8"	1/2"

PRESSURE REGULATOR. It is recommended that systems having a connection for city water be equipped with a pressure regulator set at approximately 35 psi. This valve automatically regulates the incoming water pressure to avoid damage to the pump and plumbing from excessive pressures. Model 44410-1000 (permanent flush mount) and Model 44410-1010 (in-line) pressure regulating valves are recommended for this purpose.

SUCTION FILTER. A Model 36400-0000 (strainer/filter) is recommended to be installed between the pump and fresh water tank. It helps prevent valve clogging caused by foreign material entering the pump.

WATER PURIFIER. Many water purifiers cause excessive restriction to flow, especially when element is in use for some time. When used at the main distribution line it causes the pump to cycle on and off rapidly. To minimize cycling, use an accumulator tank between pump and purifier, install purifier to feed a single outlet for drinking-water only.

ACCUMULATOR TANK. The use of an accumulator tank (Jabsco Model 30573-0000, 12573-2000 or 18810-0000), although not required, is recommended for a more effective water distribution system. It eliminates "water hammer," stores pressures to allow a limited use of water without restarting pump (desirable at night-time), assures a constant, even stream of water at faucets farthest from pump and prolongs pump life by cutting down rapid start/stop operation.

WIRING DIAGRAM

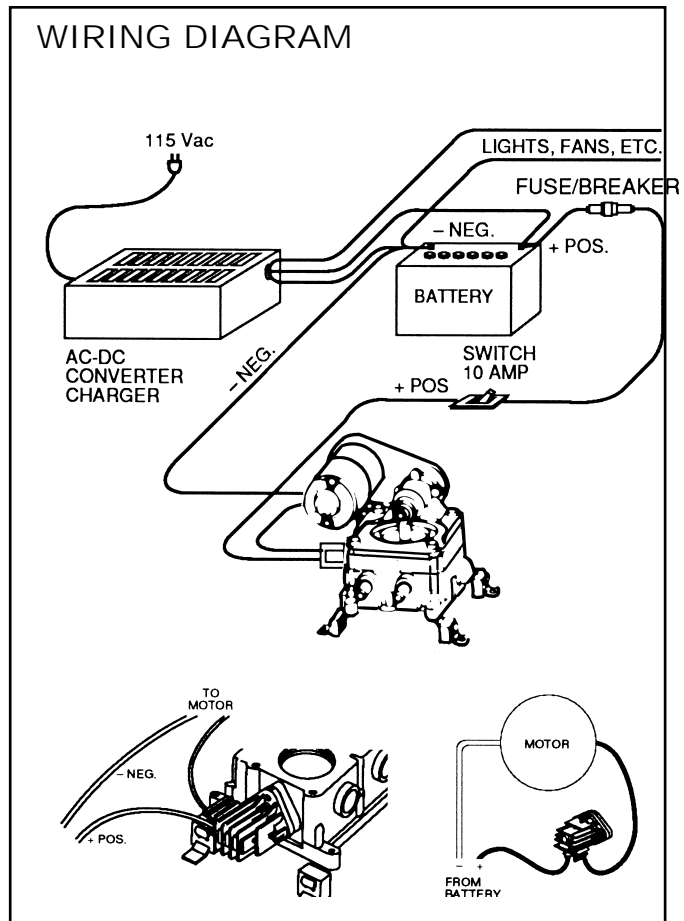

WIRING

Pump should be wired in an independent circuit according to the wiring diagram.

WIRE SIZE CHART (AWG-COPPER)

Length of circuit in feet (Sum of + Pos. & - Neg. Wire Lengths)

Voltage	Up to 80'	80' to 100'	100' to 150'
12 Vdc	14	12	10
24 Vdc	16	14	14
32 Vdc	16	16	14

MOTOR PROTECTION. The pump wiring must include a fuse/breaker in the positive lead to protect against overcurrent draw. See specification table for proper fuse rating.

SWITCHES. An on-off switch must be installed in the circuit to turn off pump when vehicle or boat is unattended, stored, in transit, or connected to city water. Use red and white label included as a reminder to shut off pump and relieve pressure in water system when idle.

AC-DC POWER CONVERTERS. AC-DC converter/charger packs should be wired to operate pump directly from the battery at all times. If the battery is bypassed and converter is used to service the pump directly, be sure the total electrical loads do not exceed the converter amp rating. Overloading the converter could result in low-voltage condition.

VOLTAGE CHECK. After installation, check the voltage at the pump motor. Voltage should be checked when pump is operating along with the inside electrical fixtures. Full voltage must be available at the pump motor at all times.

OPERATION

- Check water level in tank. Be sure valves are open and strainers and aerator are clean.
- Open all faucets, hot and cold.
- Turn on power to pump.
- Close each faucet when it starts to deliver a steady stream of water (close cold water first).
- Observe the pump. Check to be sure pump stops soon after all faucets are closed.
- Pump is now ready for automatic operation. It will start when a faucet is opened and stop when the faucet is closed.
- Turn off power to pump and open faucet to relieve pressure in system *before* hooking up to city water and when *unattended*.

MAINTENANCE

WINTER STORAGE The Jabsco pump, with its unique pulsation dampener, will withstand frozen water without damage, provided the system is not under water system air to freezing temperatures. To prevent accidental damage, the entire water system must be protected for winter storage. This requires a complete draining, using the following directions and the vehicle manufacturer's instructions:

1. Open all faucets and allow pump to empty water tanks and intake lines. Run pump dry for 1 to 2 minutes before turning off.
2. Open all drains and blow air through city water entry. Allow time for water heater to empty.
3. Disconnect discharge and intake hoses from pump. Start pump and allow to run until all water is expelled from unit. (Running dry will not harm the pump).
4. Reconnect the hoses, close the drains and leave faucets open. The water distribution system is now dry and ready for winter storage.

An alternate method is to use potable water system anti-freeze solution. Follow directions of anti-freeze manufacturer.

⚠ DANGER DO NOT USE AUTOMOTIVE TYPE RADIATOR ANTI-FREEZE. IT IS POISONOUS. USE OF THIS TYPE OF ANTI-FREEZE WILL CAUSE SERIOUS INTERNAL INJURY OR DEATH.

SERVICE

TROUBLESHOOTING

<u>Problem</u>	<u>Causes</u>
Pump operates but no water flows through faucet.	<ul style="list-style-type: none"> – Low water level in tank. – Suction line clogged or kinked. – Air leak in suction line. – Loose hose clamps or fittings in suction line.
Pump cycles on and off when faucets are closed.	<ul style="list-style-type: none"> – Water leak in plumbing. – Defective toilet flush valve. – Internal leak in pump. – Outlet valve not sealing.
Pump operates roughly and has excessive noise and vibration.	<ul style="list-style-type: none"> – Intake line is restricted, kink in suction hose or fittings too small. – Pump mounted on flimsy board. – Deformed or ruptured pulsation dampener in pump. – Loose screws at pulleys and connecting rod.
Pump fails to start when faucet is opened.	<ul style="list-style-type: none"> – No voltage to pump. – Blown fuse. – Clogged or kinked outlet line. – Defective pressure switch.
Pump fails to stop when faucets are closed.	<ul style="list-style-type: none"> – Empty water tank. – Outlet valve not sealing. – Very low voltage to pump. – Defective pressure switch.

NOTICE: Before servicing pump, turn off power to pump and open faucets to relieve pressure in water system.

VALVES REPLACEMENT

1. Remove motor and four tie down screws.
2. Expose valves by lifting jack shaft and attached diaphragm assembly from pump base.
3. Lift valves from pockets. Clean all foreign materials from valves and seats.
4. Reinstall valves into same pockets, being sure rubber valve with small hole is UP on intake and rubber valve without the small hole is DOWN on discharge (see exploded view).
NOTE: Do not use valve with small hole in rubber on discharge side of pump.
5. When reassembling, adjust belt tension to 1/4" play.

DIAPHRAGM & CONNECTING ROD REPLACEMENT

1. Remove motor and four tie down screws then lift jack shaft and attached diaphragm assembly from pump base.
2. Expose diaphragm by removing two diaphragm ring screws and detaching ring.
3. Remove diaphragm screw to separate diaphragm and plates from connecting rod. Inspect diaphragm for cuts and ruptures.
4. Remove lock nut to separate connecting rod from jack shaft.
5. When reassembling, be sure to align diaphragm and connecting rod so that rod slips straight onto jack shaft and diaphragm rests squarely on diaphragm retainer. Misalignment will create a strain on diaphragm and significantly shorten its life. Adjust belt tension to 1/4" play.

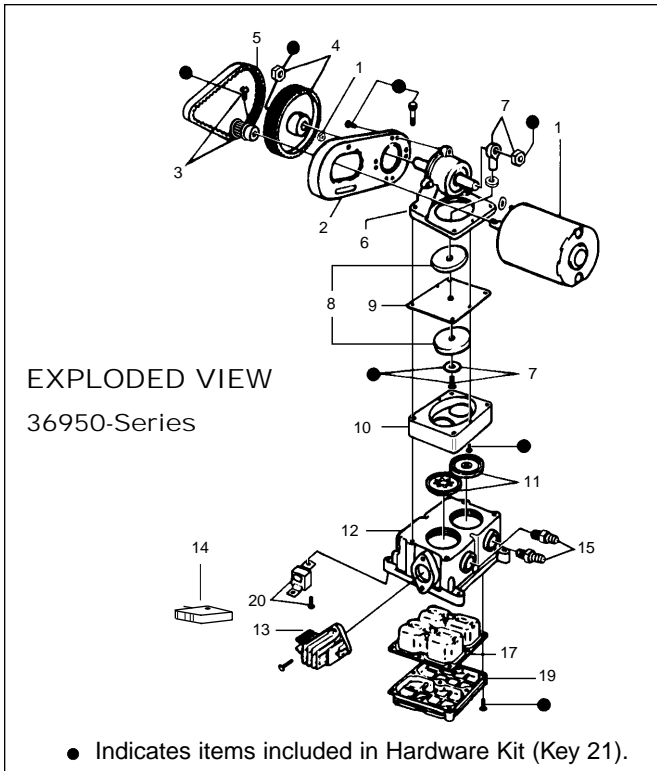

EXPLODED VIEW
36950-Series

PARTS LIST

36950-Series

Key	Part Description	Part Number	Qty
1	Motor Kit 12 Vdc.	.30200-0000	1
1	Motor Kit 24 Vdc.	.30200-0010	1
1	Motor Kit 32 Vdc.	.30200-0020	1
2	Motor Mount	.34628-0000	1
3	Small Pulley	.37169-0000	1
4	Large Pulley	.37171-0001	1
5	Belt	.30022-0000*	1
6	Jack Shaft Assembly	.35689-0001 – See Note 5	1
7	Connecting Rod Assembly	.37173-0001 – See Note 5	1
8	Diaphragm Plate	.35503-0000	2
9	Diaphragm	.30015-0000*	1
10	Retainer	.35497-0000	1
11	Valve Set (Inlet & Outlet)	.30004-0000*†	1 Set
12	Base Assembly†	.44114-1100	1
13	Pressure Switch	.37121-0010 – See Note 3 .37121-0000 – See Note 2 .44814-1000 – See Note 1	1
14	Micro Switch only	.18753-0141	1
15	Ports (Inlet & Outlet) Barb	.37176-0000† – See Note 4	1 Set
17	Pulsation Dampener	.44127-1000	1
19	Bottom Plate	.35686-0000†	1
20	Vibration Pad Kit •	.43990-0058 †	1 Set
21	Hardware Kit •	.43990-0071	1 Set
	Service Kit *•	.43990-0061	

* Indicates Parts Contained in Service Kit.
† Indicates Parts Supplied with Base Assembly.
• Except Model 36950-2180

SERVICE (continued)

PULSATION DAMPENER REPLACEMENT

1. Remove pump from installation.
2. Remove nine screws from bottom of base and bottom plate.
3. Pull out rubber pulsation dampener from base.
4. Inspect dampener for excessive deformation, ruptures and cuts.
5. When installing new pulsation dampener, make sure flange is well-seated to effect a proper water and air seal.

SWITCH REPLACEMENT – PROCEDURE A

Direct replacement of switch with threaded stem directly into pump body.

1. Disconnect power leads from switch and remove switch from pump.
2. Moisten rubber side of washer with water. Thread washer onto switch threads with metallic side of washer facing switch. Apply a thin film of sealing compound to the replacement switch threads. Keep compound clear of passage-way hole.
3. Screw replacement switch into pump base/body until snug.
4. Reconnect switch power leads.

SWITCH REPLACEMENT – PROCEDURE B

For pump base-body with flange mount and two screw holes only.

1. Disconnect power leads from switch. Remove two screws on switch flange and save. **CAUTION: These screws hold down a strong spring.** Hold switch firmly. Personal injury could result if switch body is allowed to fly loose. Remove switch housing, spring, plunger and diaphragm from base/body.
2. Remove stem, retainer, and screws from switch and discard leaving switch housing, spring, plunger, and diaphragm.
3. Insert plunger and spring assembly into base/body noting stack-up in diaphragm.
4. Cover with switch housing assembly. Hold firmly and retain with two screws saved from old switch.
5. Reconnect switch power leads.

MOTOR REPLACEMENT

1. Disconnect one motor wire from pressure switch terminal, the other from splice connector.
2. Remove two motor nuts to separate motor.
3. Loosen screw to slide off small pulley from motor shaft.
4. When assembling, be sure to adjust belt tension before tightening motor nuts. Proper adjustment is made when belt can be depressed 1/4" at a point halfway between pulleys. Do not overtighten belt.

NOTE 1 – Low Pressure Switch 10 (.7) to 20 (1.4) psi

NOTE 2 – Includes Switch and Conversion Kit to Mount New Style Switch Onto Older Style-J and -0000 Pumps.

NOTE 3 – Replacement Switch only for -2000 Series Pumps. Meets USCG Regulation 183.410 and ISO MARINE for Ignition Protection

**NOTE 4 - Threaded Outlet Port 37050-0001
Threaded Inlet Port 37050-0000**

NOTE 5 - Jack shaft assembly kit, with part number ending in 0001 includes new style connecting rod (37173-0001) with a 5/16" diameter hole and two (2) locknuts. Previous model pumps use a connecting rod (37173-0000) with a 1/4" diameter hole and a bolt.

Jabsco



ITT Industries
Engineered for life

THE PRODUCTS DESCRIBED HEREIN ARE SUBJECT TO THE JABSCO ONE YEAR LIMITED WARRANTY, WHICH IS AVAILABLE FOR YOUR INSPECTION UPON REQUEST.

U.S.A.
Jabsco
20 Icon
Foothill Ranch, CA 92610-3000
Tel: 949.609.5106
Fax: 949.859.1254

UNITED KINGDOM
Jabsco
Bingley Road, Hoddesdon
Hertfordsire EN11 0BU
Tel: +44 (0) 1992 450145
Fax: +44 (0) 1992 467132

CANADA
Fluid Products Canada
55 Royal Road
Guelph, Ontario N1H 1T1
Tel: (519) 821.1900
Fax: (519) 821.2569

JAPAN
NHK Jabsco Company Ltd.
3-21-10, Shin-Yokohama
Kohoku-Ku, Yokohama, 222
Tel: 045.475.8906
Fax: 045.475.8908

GERMANY
Jabsco GmbH
Oststrasse 28
22840 Norderstedt
Tel: +49-40-53 53 73 -0
Fax: +49-40-53 53 73 -11