

PUMP DIMENSIONS

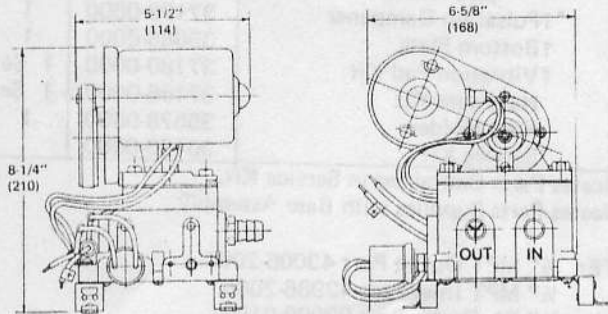

Dimensions in parenthesis are in millimeters.

OPERATION

- Check level of water in tank.
- Check all strainers or any aerators and clean thoroughly.
- Open all faucets, hot and cold.
- Turn on power to pump and wait for hot water tank and water lines to fill.
- Close each faucet when it starts to deliver a steady stream of water (close cold water faucet first).
- Observe the pump. Check to be sure pump stops soon after closing last faucet.
- Pump is now ready for automatic operation. It will start when a faucet is opened and stop when the faucet is closed.
- Relieve system pressure before hooking up to city water.

MAINTENANCE

WINTER STORAGE. PAR pumps, with their unique pulsation dampener, will withstand frozen water without damage, provided the system is not under pressure prior to freezing. To prevent accidental damage, the entire water system should be protected from freezing during winter storage. This requires complete draining, using the following directions and/or vehicle manufacturers instructions:

1. Open all faucets and drains and allow pump to empty water tank and intake line. Run the pump dry for 1 to 2 minutes before turning off.
2. With all drains open, blow air through city water entry. Allow time for the water heater to empty. Disconnect discharge and intake hoses from the pump. Start the pump and allow to run until all water is expelled from unit. (Running dry will not harm the pump.)
4. Reconnect the hoses, close the drains but leave faucets open. The water distribution system is now dry and ready for winter storage.

An alternate method is to use potable water system anti-freeze solution. Follow directions of anti-freeze manufacturer, and use a PAR Winter Protection Kit Model 44610-0000.

DO NOT USE AUTOMOTIVE TYPE RADIATOR ANTI-FREEZE. IT IS POISONOUS.

FEATURES

- Self-Priming
- Diaphragm Design Allows Dry Running
- Built-in Discharge Check Valve
- Quiet Operation
- Fuse Protected
- Built-in Hydraulic Pulsation Dampener
- Large Vibration Absorbing Pads
- Available with Barb or Threaded Ports
- IAPMO Approved
- CSA Certified

SPECIFICATIONS

	U.S. GPM	Liters/Min.	Can. GPM
Open Flow:	3.0	11.4	2.5
Cut-in Pressure:	16 PSI Nom. (1,1kg/cm)		
Cut-off Pressure:	26 PSI Nom. (1,8kg/cm)		
Voltage:	12VDC		
Current:	6 Amps Nominal		
Fuse Rating:	6¼ Amps "Slo-Blo"/8 Amp Normal		
Vert. Dry Suction Lift:	5 Feet (1,52M)		
Ports:	Slip-on 1/2" or 5/8" I.D. Hose or 1/2" Threads		
Weight:	11 lbs.	5.0 kgs.	
Approval:	IAPMO Type IV and CSA		

TROUBLE SHOOTING

Problem	Causes
Pump operates but no water flows through faucet.	<ul style="list-style-type: none"> -Low water level in tank. -Suction line clogged or kinked. -Air leak in suction line. -Loose hose clamps or fittings in suction line. -Defective valves or check valve.
Pump cycles on and off when faucets are closed.	<ul style="list-style-type: none"> -Water leak in plumbing. -Defective toilet flush valve. -Internal leak in pump. -Outlet valve not sealing.
Pump operates roughly and has excessive noise and vibration.	<ul style="list-style-type: none"> -Intake line is restricted, kink in suction hose or fittings too small. -Pump mounted on flimsy board. -Deformed or ruptured pulsation dampener in pump. -Loose screws at pulleys and connecting rod.
Pump fails to start when faucet is opened.	<ul style="list-style-type: none"> -No voltage to pump. -Blown fuse. -Clogged or kinked outlet line. -Defective pressure switch.
Pump fails to stop when faucets are closed.	<ul style="list-style-type: none"> -Empty water tank. -Outlet valve not sealing. -Very low voltage to pump -Air in system. -Defective pressure switch.

EXPLODED VIEW

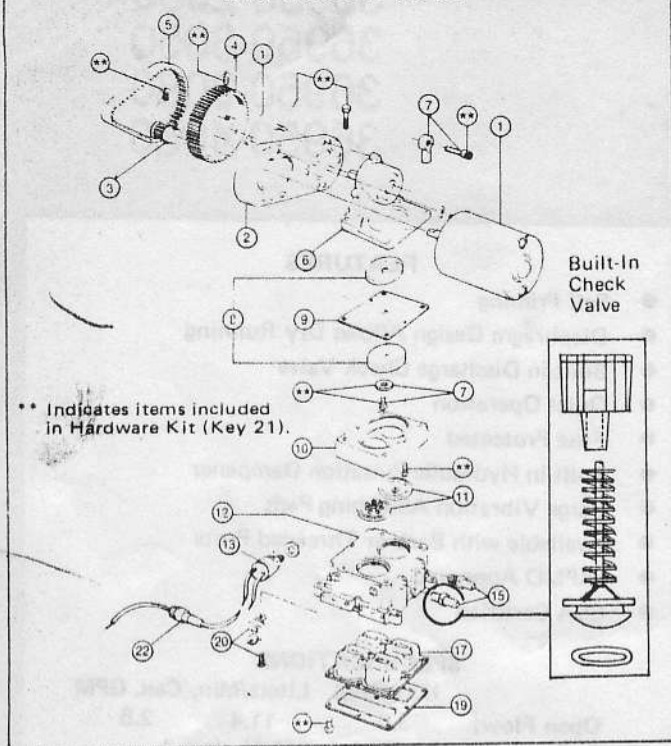

SERVICE

CAUTION: Before servicing pump, turn off power and open faucet to relieve pressure in water system.

VALVES REPLACEMENT

1. Remove motor and four tie down screws.
2. Expose valves by lifting jack shaft and attached diaphragm assembly from pump base.
3. Lift valves from pockets. Clean all foreign materials from valves and seats.
4. Reinstall valves into same pockets, being sure rubber valve with small hole is UP on intake and rubber valve without the small hole is DOWN on discharge (see exploded view).
CAUTION: Do not use valve with small hole in rubber on discharge side of pump.
5. When reassembling, adjust belt tension to 1/4" play.

DIAPHRAGM & CONNECTING ROD REPLACEMENT

1. Remove motor and four tie down screws then lift jack shaft and attached diaphragm assembly from pump base.
2. Expose diaphragm by removing two diaphragm ring screws and detaching ring.
3. Remove diaphragm screw to separate diaphragm and plates from connecting rod. Inspect diaphragm for cuts and ruptures.
4. Remove eccentric screw to separate connecting rod from jack shaft.
5. When reassembling, be sure to align diaphragm and connecting rod so that rod slips straight onto jack shaft and diaphragm rests squarely on diaphragm retainer. Misalignment will create a strain on diaphragm and significantly shorten its life. Adjust belt tension to 1/4" play.

PULSATION DAMPENER REPLACEMENT

1. Remove pump from installation.
2. Remove nine screws from bottom of base and bottom plate.
3. Pull out rubber pulsation dampener from base.
4. Inspect dampener for excessive deformation, ruptures and cuts.
5. When installing new pulsation dampener, make sure flange is well-seated to effect a proper water and air seal.

PARTS LIST

36950-Series

Key	Description	Part Number	Qty.
1	Motor Kit	30200-0000	1
2	Motor Mount	34628-0000	1
3	Small Pulley	37169-0000	1
4	Large Pulley	37171-0000	1
5	*Belt	30022-0000	1
6	Jack Shaft Assembly	35689-0000	1
7	Connecting Rod Assembly	37173-0000	1
8	Diaphragm Plates	35503-0000	2
9	*Diaphragm	30015-0000	1
10	Retainer	35497-0000	1
11	*†Valve Set (Inlet & Outlet)	30004-0000	1 Set
12	†Base Assembly	35620-1100	1
13	Pressure Switch	44814-0000	1
15	Ports (Inlet & Outlet) Barb (See Note)	37176-0000	1 Set
17	*†Pulsation Dampener	37178-0000	1
19	†Bottom Plate	35686-0000	1
20	†Vibration Pad Kit	37180-0000	1 Set
21	Hardware Kit	37166-0000	1 Set
22	Fuse Holder	35578-0000	1
	*Service Kit	30126-0000	

*Indicates Parts Contained in Service Kit.

†Indicates Parts Supplies with Base Assembly.

NOTE: 1/2" MPT Outlet Port 43006-2000
 1/2" MPT Inlet Port 42986-2000
 1/2" FL Outlet Port 93009-0192
 1/2" FL Inlet Port 93009-0193

PRESSURE SWITCH REPLACEMENT

1. Disconnect wires from pressure switch.
2. Unscrew switch from base.
3. Thread new switch with sealing washer into pump base, with metallic side of washer facing switch. Tighten securely.
4. Rewire one lead to motor, other to fuse holder.

MOTOR REPLACEMENT

1. Disconnect one motor wire from pressure switch, the other from splice connector.
2. Remove two motor nuts to separate motor.
3. Loosen screw to slide off small pulley from motor shaft.
4. When reassembling, be sure to adjust belt tension before tightening motor nuts. Proper adjustment is made when belt can be depressed one-quarter inch at a point halfway between pulleys. Do not overtighten.

CHECK VALVE REPLACEMENT

1. Remove water line from output port.
2. Pull poppet retainer from port using wire hook or long-nosed pliers.
3. Inspect poppet with "O"-ring, stainless steel spring and retainer-guide. Clean and reinstall or replace.

APPROVED



T-1220



RV

STD Z240.3.2

JABSCO PRODUCTS ITT

Marine and Recreation Components Division
 International Telephone and Telegraph Corporation
 1485 Dale Way, Costa Mesa, California 92626

Telephone: (714) 545-8251