

JABSCO®

Model 36740-Series

FLEXMOUNT 3" BLOWERS FEATURES

- Tough Reinforced Plastic Housing
- Universal Flexmount Bracket Permits Outlet to Face Any Direction
- Slip-On Inlet and Outlet Ducting Connection
- Efficient High Volume Airflow
- Low Current Draw
- Corrosion-Resistant Materials Throughout
- N.M.M.A. Type Accepted
- Meets USCG Regulation 183.410 and ISO 8846 MARINE for Ignition Protection
- DC Models Comply with ISO 9097 MARINE

INSTALLATION

INSTALLATIONS MUST MEET APPLICABLE SECTIONS OF TITLE 33, PART 183; SUBPART K, USCG VENTILATION REGULATIONS.

MOUNTING: Jabsco blowers are primarily intended for intermittent duty cycles such as evacuating fuel vapors from bilge areas. If desired, they also may be used for other general air circulation applications with longer duty cycles. However, when doing so, it should be noted that the maximum motor life is approximately 1000 hours. Therefore, the blower should only be used for applications if this length of service is acceptable. For continuous duty applications, ask your dealer about Jabsco Heavy Duty Long Life Blowers. Mount blower on flat bulkhead surface in highest part of compartment free from spray or deck wash. Blower may be rotated in mounting bracket to facilitate the shortest route of ducting. Use a suitable discharge fitting so that static pressure of blower will not be affected by change in wind direction. Route inlet ducting with as few bends as possible to lower 1/3 of the bilge compartment where vapors are likely to accumulate. Be sure ducting is positioned below top of engine stringers but not so low as to become submerged in bilge water. Locate pickup to take advantage of natural airflow direction. Jabsco flexible ducting No. 34959-0100 is easy to cut and install.

NOTICE: Blower should be mounted away from extreme heat (more than 130°F) to prevent distortion of blower wheel or housing.

For an exposed inlet, ventilator intake screen No. 34764-0000 provides a safe and attractive protected inlet.

OPERATION: See following warning placard statement.

⚠ WARNING



Explosion hazard. Gasoline vapors can explode. Before starting engine, operate blower for 4 minutes and check engine compartment bilge for gasoline vapors. Run blower below cruising speed. Failure to do so can result in injury or death.



Model 36740-Series

SPECIFICATIONS

| Model | Airflow | Voltage | Amps | Fuse Size | Weight lb(kg) |
|------------|---------------------------------------|---------|------|-----------------|-----------------|
| 36740-0000 | 150 CFM (4,2 m ³ /min.) | 12 Vdc | 6.8 | 10 A | 5.5 (2,5 kg) |
| 36740-0010 | 150 CFM (4,2 m ³ /min.) | 24 Vdc | 3.3 | 5 A | 5.5 (2,5 kg) |
| 36740-0031 | 140 CFM (4,0 m ³ /min.) | 115 Vac | 0.8 | 1.25 A 115 V | 5.0 (2,3 kg) |

INSTALLATION DRAWING

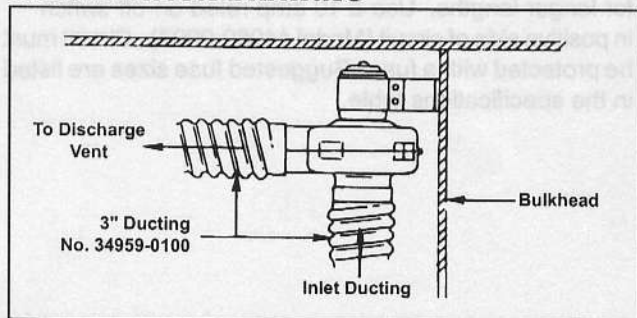

THE "WARNING" PLACARD SUPPLIED WITH BLOWER MUST BE MOUNTED ADJACENT TO ENGINE IGNITION SWITCHES (ALL LOCATIONS) TO COMPLY WITH TITLE 33, PART 183; SUBPART K, USCG VENTILATION REGULATIONS. *

*Additional warning placards are available from factory by requesting form 43003-0418.

PARTS LIST

| Key | Part Description | Part Number | Qty. |
|-----|---|-------------|------|
| 1 | Bracket Assembly (includes screw & nut) | 43899-000 | 1 |
| 2 | Motor Kits: | | |
| | 12Vdc | 30200-0000 | |
| | 24Vdc | 30200-0010 | |
| | 32Vdc | 30200-0020 | |
| | 115Vac | 30200-0050 | |
| 3 | Blower Housing | 35772-0000 | 1 |
| 4 | Blower Wheel | 34742-0001 | 1 |
| 5 | Blower Housing | 35773-0000 | 1 |
| 6 | Screw – 8 x 5/8 SS Self Tapping Pan Head | 35508-0000 | 5 |

PARTS VIEW

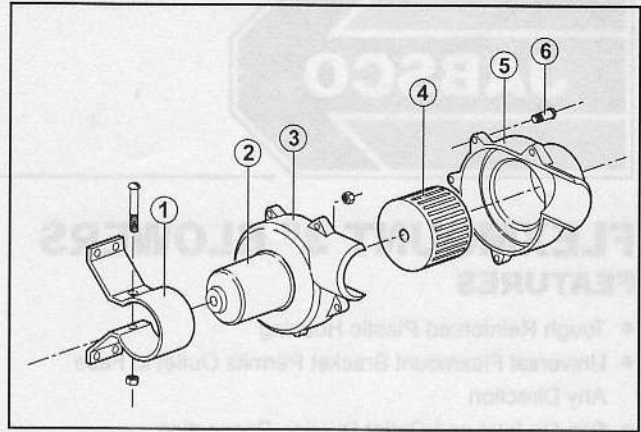

MARINE SWITCH PANELS

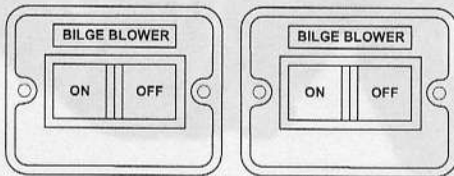

44960-0002
Lighted Switch with
Boot SPST
(For DC Blowers Only)

44960-0003
Unlighted SPST
(For AC or DC Blowers)

DIMENSIONAL DRAWING

Inches (millimeters)

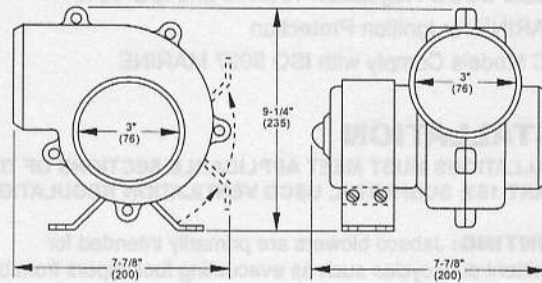

WIRING FOR DC MODELS

Use stranded copper wire. For lengths up to 25 feet (7.6 m) from power source: use 12 gauge wire for 12 Volt, 14 gauge wire for 24 Volt. Use larger wire for longer lengths. Use a 10 amp rated on-off switch in positive side of circuit (Model 44960-0003). Circuit must be protected with a fuse. Suggested fuse sizes are listed in the specifications table.

WIRING FOR AC MODEL

Use 16 gauge stranded copper wire for lengths up to 100 feet from power source. Connect the grounded, unswitched conductor (white) to the white motor lead. Connect the ungrounded, switched conductor (black) to the black motor lead. This conductor should include, at the power source, a 1.25 amp 125 Volt fuse. The green motor lead must be connected to the AC circuit ground.

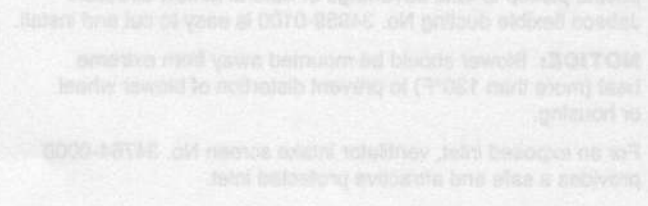

THE WIRING PLACARD SUPPLIED WITH BLOWER MUST BE MOUNTED ADJACENT TO ENGINE IGNITION SWITCHES (ALL LOCATIONS) TO COMPLY WITH TITLE 23, PART 183, SUBPART K, USCG VENTILATION REGULATIONS.

*Additional wiring details are available from factory by requesting form 44960-0010.

OPERATOR: See following warning placard statement.
Explosion hazard. Examine vapors and vapors. Before starting engine, operate blower for 4 minutes and check engine compartment area for excessive vapors. Run blower before starting speed. Failure to do so can result in injury or death.



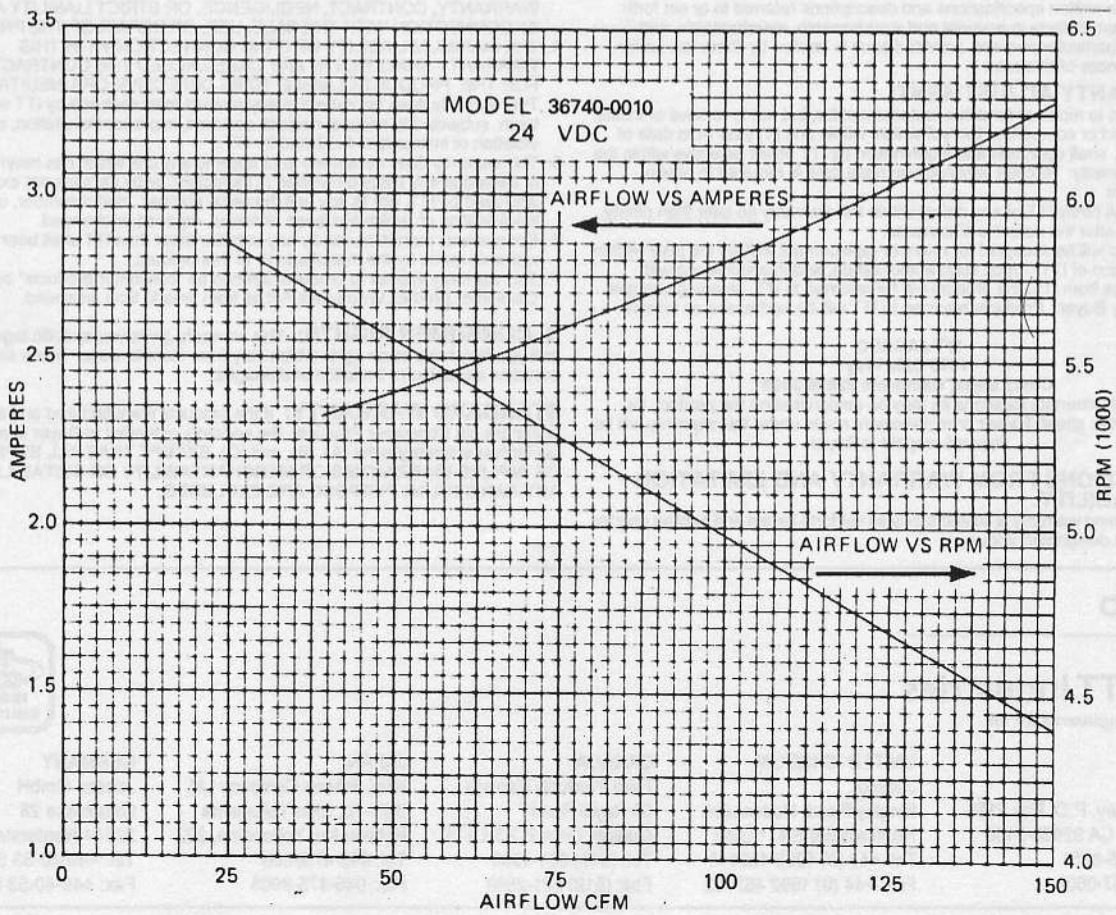
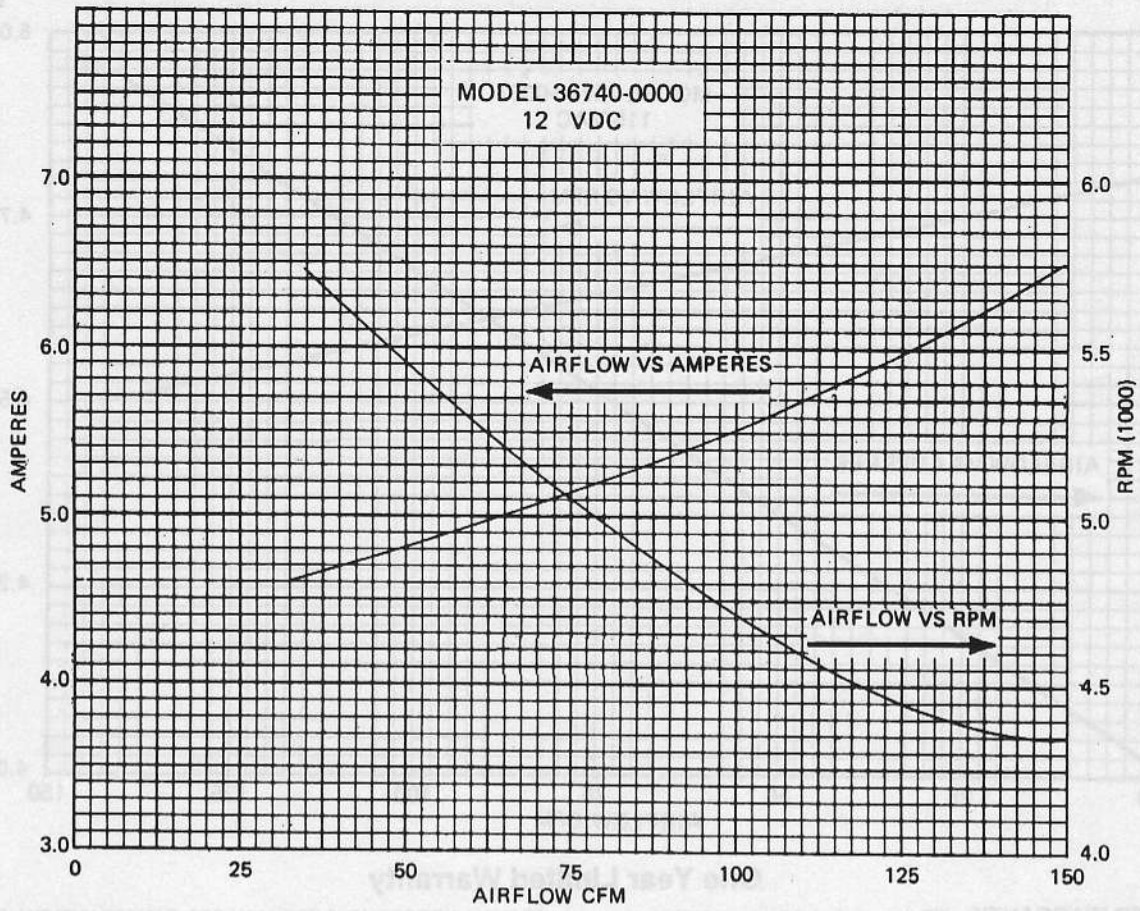

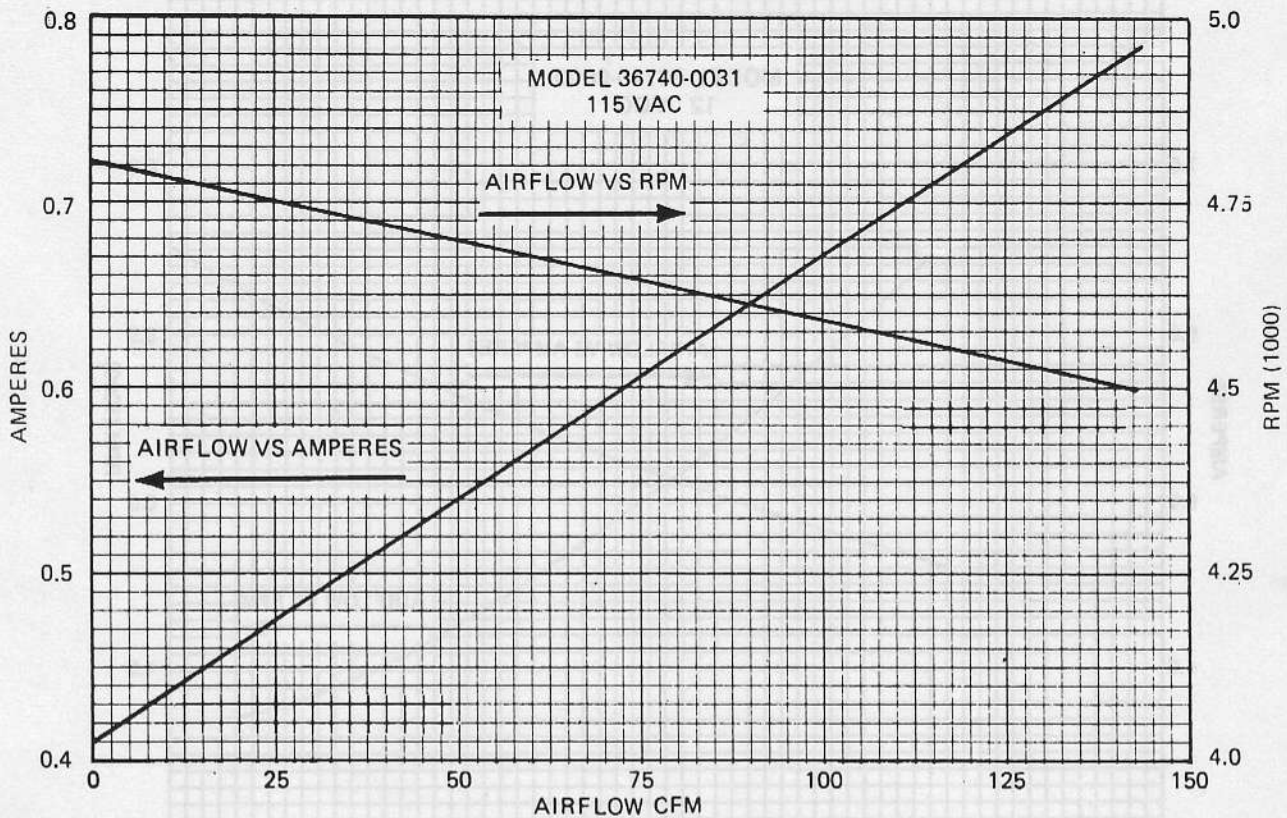

One Year Limited Warranty

A. LIMITED WARRANTY: ITT warrants that at the time of shipment, the products manufactured by ITT and sold hereunder shall be in conformity with applicable written specifications and descriptions referred to or set forth herein, free from defects in material and workmanship, merchantable, and suitable for a particular purpose, provided such is implied by State law under the circumstances of this sale.

B. WARRANTY ADJUSTMENT:

- ITT agrees to repair or furnish a replacement for, but not to remove or install, any product or component thereof which, within one (1) year from date of purchase, shall upon test and examination by ITT prove defective within the above warranty. Receipt verifying purchase date is required to obtain adjustment.
- Buyer shall notify ITT of any defect within this warranty no later than ninety (90) days after the defect is discovered.
- No product will be accepted for return or replacement without the prior written authorization of ITT. Upon such authorization, and in accordance with instructions from ITT, the product will be returned to ITT, shipping charges prepaid by Buyer. Products returned to ITT will be addressed as follows:

ITT JABSCO
1485 Dale Way
Costa Mesa, California 92626-3998

Or to such alternate locations as may be designated on the product, its container, or this sheet. Repair or replacement made under this warranty will be shipped prepaid to Buyer.

C. EXCLUSIONS FROM WARRANTY AND LIMITATION OF LIABILITY:

- The foregoing warranty is limited solely as set forth herein and applies only for the period designated above.

- ITT SHALL NOT BE LIABLE FOR ANY LOSS, DAMAGE, SPECIAL OR CONSEQUENTIAL DAMAGE OF ANY KIND, WHETHER BASED UPON WARRANTY, CONTRACT, NEGLIGENCE, OR STRICT LIABILITY ARISING IN CONNECTION WITH THE SALE, USE, OR REPAIR OF THE PRODUCT.
- THE MAXIMUM LIABILITY OF ITT IN CONNECTION WITH THIS WARRANTY SHALL NOT IN ANY CASE EXCEED THE CONTRACT PRICE FOR THE PRODUCT CLAIMED TO BE DEFECTIVE OR UNSUITABLE.
- This warranty does not extend to any product manufactured by ITT which has been subjected to misuse, neglect, accident, improper installation, or use in violation of instructions furnished by ITT.
- This warranty does not extend to or apply to any unit which has been repaired or altered at any place other than ITT's factory, or by persons not expressly approved by ITT, nor to any unit the serial number, model number, or identification of which has been removed, defaced or changed.
- Components manufactured by any supplier other than ITT shall bear only that warranty made by the manufacturer of that product.
- This warranty applies to products defined as "consumer products" by the Consumer Product Warranties Act as from time to time amended.

D. CONSUMER RIGHTS: This warranty gives you specific legal rights, and you may have other rights which vary from state to state. Some states do not allow exclusion or limitation of damages.

STANDARD WARRANTY: If the products manufactured and sold here under are not Consumer Products, the warranty extended to Buyer shall be as set forth in subparagraphs (A), (B), and (C), EXCEPT THAT ALL EXPRESS OR IMPLIED WARRANTIES OR MERCHANTABILITY OR SUITABILITY FOR ANY PARTICULAR PURPOSE ARE EXCLUDED.

Jabsco



U.S.A.
Jabsco
1485 Dale Way, P.O. Box 2158
Costa Mesa, CA 92628-2158
Tel: (714) 545-8251
Fax: (714) 957-0609

UNITED KINGDOM
Jabsco
Bingley Road, Hoddesdon
Hertfordshire EN11 0BU
Tel: +44 (0) 1992 450145
Fax: +44 (0) 1992 467132

CANADA
Fluid Products Canada
55 Royal Road
Guelph, Ontario N1H 1T1
Tel: (519) 821-1900
Fax: (519) 821-2569

JAPAN
NHK Jabsco Company Ltd.
3-21-10, Shin-Yokohama
Kohoku-Ku, Yokohama, 222
Tel: 045-4758906
Fax: 045-475-8908

GERMANY
Jabsco GmbH
Oststrasse 28
22844 Norderstedt
Tel: +49-40-53 53 73 -0
Fax: +49-40-53 53 73 -11