

**PAR**

# Model 36251-2 SERIES

Model 36251-2 SERIES

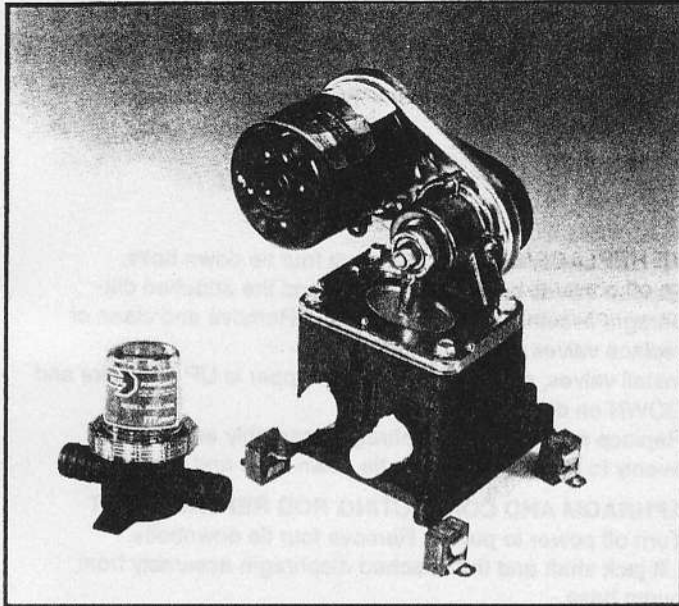

## ELECTRIC SHOWER DRAIN PUMP

### FEATURES

- Self-Priming
- Diaphragm Design Allows Dry Running
- Quiet Operation
- Built-in Hydraulic Pulsation Dampener
- Permanently Lubricated Ball Bearings on Shaft and Connecting Rod
- Corrosion Resistant Materials Throughout for Fresh or Salt Water Service
- Meets USCG Electrical Standards

### SPECIFICATIONS

	U.S. GPM	Liters/Min.	Imp. GPM
Open Flow:	2.0	7,5	1.7
Vert. Dry Suction Lift:	5 Feet (1,5M)		
Ports:	3/4" Slip-on Hose		
Weight:	8 lbs (3,6 kgs)		

### INSTALLATION

#### MOUNTING

Mount upright in a dry location (above highest bilge water level) on a solid surface. Selection of a dry, cool, ventilated location will generally extend pump life.

#### LUBING

For intake and discharge use 3/4" ID non-collapsible hose. Keep intake and discharge line free of kinks and restrictions. Install the pumpguard supplied (PAR Model 36200-0000) in the intake line from the sump to protect pump from debris. Use a 3/4" thru-hull fitting for discharge.

#### WIRING

Wire pump in a circuit independent of all other electrical fixtures. Use stranded copper wire. Install fuse in positive leads. See table for recommended wire and fuse size. See diagram for wiring instructions. Use a 10 amp-rated switch (PAR 44960-Series). After installation, it is recommended that voltage be checked at the motor terminals with motor operating under full load and all other appliances in the circuit operating. Voltage should not be less than 90% of rated motor voltage.

### STANDARD MODELS

Model	Voltage	Amperage (Nominal)
36251-2000	12 VDC	5
36251-2010	24 VDC	3
36251-2020	32 VDC	2

### MAINTENANCE

**WINTER STORAGE:** When possible it is preferred that the complete pump be removed and stored in a warm dry place. If this is not possible the pump must be completely drained, hoses removed and pump run until all water is expelled.

### WIRING AND FUSE SIZE

Wire Length Between Battery and Motor	Model 36251-2000 12 Volt	Model 36251-2010 24 Volt	Model 36251-2020 32 Volt
1-25 feet	12 AWG	14 AWG	16 AWG
25-50 feet	12 AWG	14 AWG	14 AWG
Fuse Size: Slow Blow Standard	5 AMP	3 AMP	2 AMP
	7 AMP	4 AMP	3 AMP

### DIMENSIONAL DRAWING

inches (millimeters)

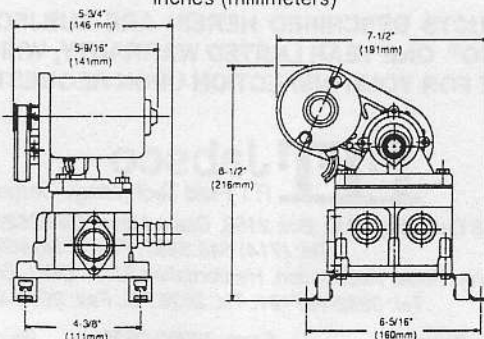

### WIRING DIAGRAM

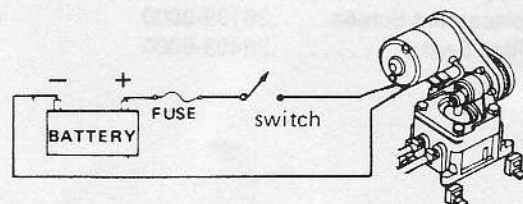

## EXPLODED VIEW

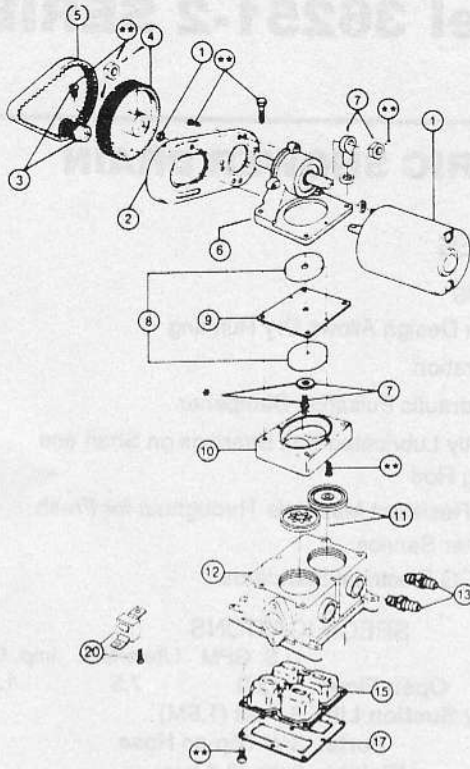

\*\* Indicates items included in Hardware Kit (Key 21).

## PART LIST

### 36251-Series

Key	Part Description	Part Number	Qty
1	Motor Kit 12 Vdc. ....	30209-0000	1
1	Motor Kit 24 Vdc. ....	30200-0010	1
1	Motor Kit 32 Vdc. ....	30200-0020	1
2	Motor Mount .....	34628-0000	1
3	Small Pulley .....	37169-0000	1
4	Large Pulley .....	37171-0001	1
5	Belt .....	30022-0000*	1
6	Jack Shaft Assembly .....	35689-0001	1
7	Connecting Rod Kit .....	37173-0001	1
8	Diaphragm Plate .....	35503-0000	2
9	Diaphragm .....	30015-0000*	1
10	Retainer .....	35173-0000	1
11	Valve Set (Inlet & Outlet) .....	30004-0000*	1 Set
12	Base Assembly† .....	44114-1000	1
13	Ports (Inlet & Outlet) Barb. ....	37175-0000†	1 Set
15	Pulsation Dampener .....	44127-1000	1
17	Bottom Plate .....	35686-0000†	1
20	Vibration Pad Kit .....	43990-0058†	1 Set
21	Hardware Kit .....	43990-0071	1 Set
	Service Kit * .....	43990-0061	

\* Indicates Parts Contained in Service Kit.

† Indicates Parts Supplied with Base Assembly.

Pumpgard .....36200-0000  
 Replacement Screen....36139-0000  
 O-Ring Seal.....36403-0000

## TROUBLESHOOTING

### Problems

Loss of suction to pump

## SERVICE

### Causes

- Air leak in suction line or pumpgard.
- No water in sump.
- Intake hose kinked or plugged.
- Fouled intake or discharge valve.
- Ruptured diaphragm.

Rough or noisy operation.

- Intake or discharge hose kinked or plugged. Pumpgard clogged.
- Pump not mounted firmly.
- Loosened eccentric screw.
- Ruptured or collapsed pulsation dampener.

Pump fails to start.

- No voltage to pump.
- Blown fuse.
- Clogged outlet line.

## VALVE REPLACEMENT

1. Turn off power to pump. Remove four tie down bolts.
2. Expose valves by lifting jack shaft and the attached diaphragm assembly from pump base. Remove and clean or replace valves.
3. Install valves, making sure rubber flapper is UP on intake and DOWN on discharge.
4. Replace motor-mount-diaphragm assembly and fasten evenly to base with the four tie down bolts and washers.

## DIAPHRAGM AND CONNECTING ROD REPLACEMENT

1. Turn off power to pump. Remove four tie downbolts.
2. Lift jack shaft and the attached diaphragm assembly from pump base.
3. Remove two diaphragm retainer screws and the bottom diaphragm retainer.
4. Remove lock nut. Remove connecting rod and diaphragm from the top of diaphragm retainer, then unscrew bolt to separate diaphragm plates.
5. Check diaphragm for cuts and cracks. Check rod assembly bearing for excessive wear. Replace if badly worn.
6. Loosely reassemble diaphragm, diaphragm plates, connecting rod spacer and diaphragm bolt onto connecting rod. Firmly secure connecting rod to jack shaft with the lock nut. Secure diaphragm to upper diaphragm retainer with the bottom diaphragm retainer and two screws.
7. Tighten connecting rod bolt.
8. Replace motor-mount-diaphragm assembly and fasten evenly to base with the four tie down bolts and washers.

## PULSATION DAMPENER REPLACEMENT

1. Disconnect power leads from pump and remove from mount.
2. Remove nine bottom plate screws and the bottom plate. Pull out and replace pulsation dampener.
3. Replace bottom plate and screws. Tighten evenly to ensure an air and water seal.
4. Reinstall pump and reconnect power leads.

**THE PRODUCTS DESCRIBED HEREIN ARE SUBJECT TO THE JABSCO® ONE YEAR LIMITED WARRANTY, WHICH IS AVAILABLE FOR YOUR INSPECTION UPON REQUEST.**

# ITT Jabsco

ITT Fluid Technology Corporation  
 1485 Dale Way, P.O. Box 2158, Costa Mesa, Ca 92628-2158  
 Tel: (714) 545-8251; Fax: (714) 957-0609  
 Bingley Road, Hoddesdon, Hertfordshire EN11 OBU, England  
 Tel: 0992-467191; Tlx: 26351 G; Fax: 0992-467191