

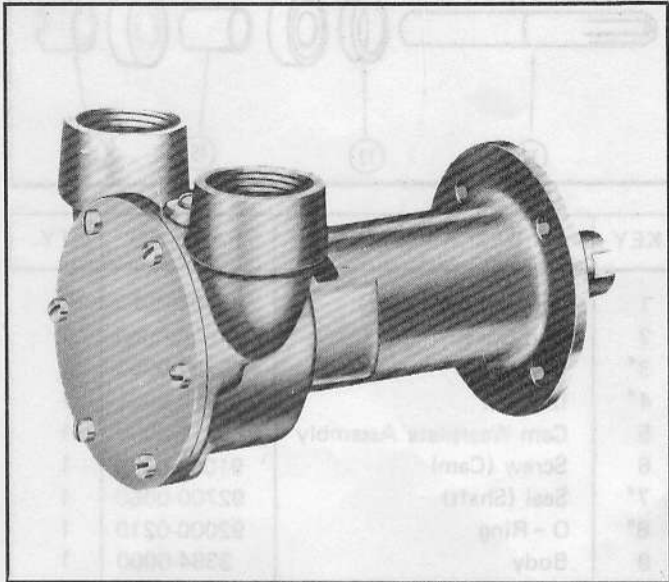

# Model 3380-0001



MODEL: 3380-0001

## Self-Priming Pumps FEATURES

- Body: Bronze
- Impeller: Jabsco Neoprene Compound
- Shaft: 316 Stainless Steel
- Shaft Seal: Lip Type
- Ports: 1/2" NPT
- Weight: Approx. Shipping Wght. 5 1/2 lbs

APPLICATION:  
Marine Engine Cooling

### FOR ENGINE MODELS:

- CHRIS CRAFT - K Series (95 to 120 HP)
- HERCULES - QX
- KERMATH - Sea Prince
- OSCO - Hercules Diesel 470 (and others)
- PALMER - PH75 - PH125
- UNIVERSAL - Explorer 6 - Model OK  
Master 6 - Model OL

Model 3380-0001

### DIMENSIONAL DRAWING

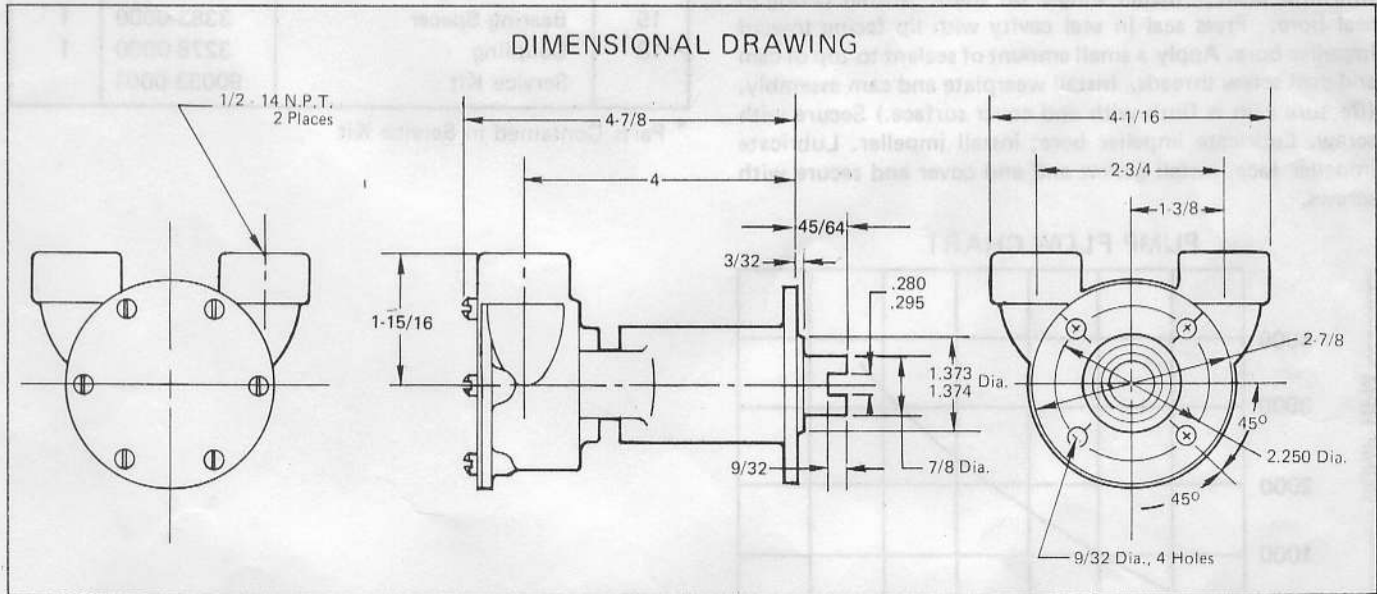

### INSTALLATION INSTRUCTIONS

Engage shaft with drive tang, make sure flange seats squarely on mounting surface and bolt to engine. Connect inlet and outlet fittings using pipe compound to seal threads.

### OPERATING INSTRUCTIONS

Pump will self prime at low or high speeds. Make sure scoop and inlet line are clear and all connections air tight. Do not run pump dry for more than 30 seconds. Lack of water flow may damage impeller. To drain pump, loosen end cover screws.

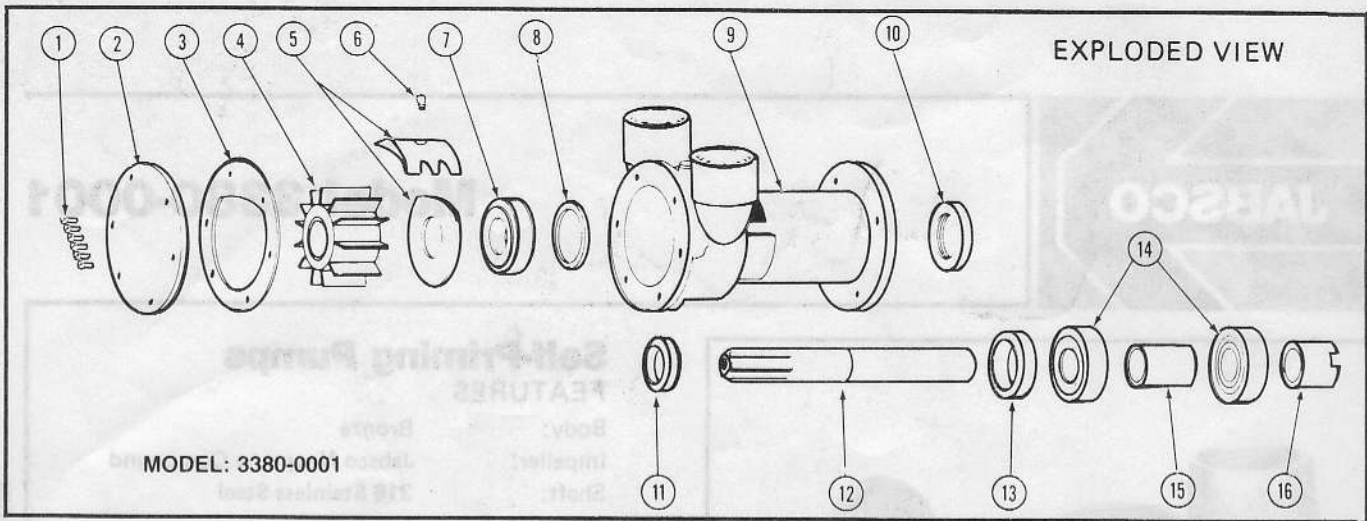

**SERVICE INSTRUCTIONS**

**IMPELLER REPLACEMENT:** Remove end cover and gasket. Pull impeller out by grasping hub with pliers. Replace impeller, gasket and end cover. A light coating of grease in impeller bore will aid priming on dry start up. (Use correct Jabsco gasket; a thicker or thinner gasket may cause impeller damage.) Standard gasket is 0.010" thick.

**MAJOR REPAIR:** Remove pump from engine to replace seal, bearings or shaft. To disassemble pump, remove end cover, gasket and impeller as outlined above. Press on impeller end of shaft to remove shaft and bearing assembly. Remove cam and wearplate assembly. Use screw driver to pry bearing seal out of bearing bore. Press shaft seal out towards impeller bore. Replace all worn parts. When installing coupling, support splined end of shaft. Press bearing seal in bearing bore with lip towards bearing. Press shaft and bearing assembly into bearing bore. Press adaptor ring into body. Install slinger on shaft. Install O-ring in seal bore. Press seal in seal cavity with lip facing toward impeller bore. Apply a small amount of sealant to top of cam and cam screw threads. Install wearplate and cam assembly. (Be sure cam is flush with end cover surface.) Secure with screw. Lubricate impeller bore; install impeller. Lubricate impeller face, install gasket and end cover and secure with screws.

KEY	DESCRIPTION	PART NO.	QTY.
1	Screws (End Cover)	91002-0020	6
2	End Cover	11830-0000	1
3*	Gasket	5212-0000	1
4*	Impeller	1210-0001	1
5	Cam Wearplate Assembly	5211-0000	1
6	Screw (Cam)	91003-0090	1
7*	Seal (Shaft)	92700-0060	1
8*	O - Ring	92000-0210	1
9	Body	3384-0000	1
10	Adaptor Ring	3376-0000	1
11	Slinger	3286-0000	1
12	Shaft	5857-0000	1
13	Bearing Seal	92700-0180	1
14	Ball Bearings	92600-0130	2
15	Bearing Spacer	3383-0000	1
16	Coupling	3278-0000	1
	Service Kit	90033-0001	

\* Parts Contained in Service Kit

**PUMP FLOW CHART**

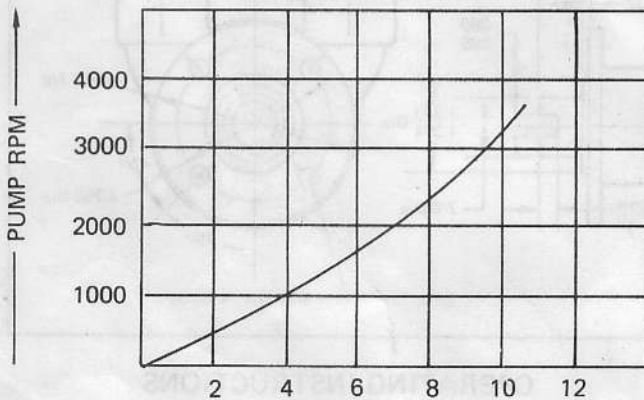

Typical flow in average engine cooling application.\*

\* Average engine cooling applications have discharge pressures of 10 - 15 PSI and intake vacuums of 3 - 5 inches of mercury.

**THE PRODUCT DESCRIBED HEREIN IS SUBJECT TO THE JABSCO ONE YEAR LIMITED WARRANTY, WHICH IS AVAILABLE FOR YOUR INSPECTION UPON REQUEST.**

**ITT JABSCO**

A Unit of ITT Corporation

1485 Dale Way, P.O. Box 2158, Costa Mesa, CA 92628-2158, Tel: (714) 545-8251  
 Bingley Road, Hoddesdon, Hertfordshire EN11 0BU England, Tel: +44-992-467191