

FEATURES

- Smooth Flow
- Self-Priming up to 10 feet (3m)
- Dry running capability
- Soft noise absorbing mounts
- Snap-fit port fittings
- Built-in bypass — less pulsation
- Reduces need for accumulator tank
- Corrosion resistant materials
- Thermal overload protection
- Motor rating: IP 54
- CSA listed
- ISO 8846 MARINE (ignition protection)
- CE

SPECIFICATIONS

Motor: Permanent Magnet, Ball Bearing Totally Enclosed.
Not for Continuous Duty. Intermittent Duty Only.

Pump: Body - Polypropylene
Diaphragm - Santoprene
Valves - EPDM



Fittings: (2) 1/2" - 14 Male pipe
(2) 1/2" (13 mm) Hose Barbs



31295 / 31395 - Series

Pump Series	Dimensions - Inches (mm)			Weight lb. (kg)
	Height	Width	Length	
31X95-XXXX	4-3/4" (121)	6" (152)	9" (229)	3.5 (1.6 kg)

MODEL	VOLTS	AMP DRAW (A) @ 10 psi (0.7 bar)	FUSE SIZE (A)	OPEN FLOW GPM (l/min)	MAX PSI (bar)
31395-0092	12V dc	4.4	10	2.9 (11)	50 (3.4)
31395-0094	24V dc	2.2	5	2.9 (11)	50 (3.4)
31395-0392	12V dc	4.4	10	2.9 (11)	40 (2.7)
31395-0394	24V dc	2.2	5	2.9 (11)	40 (2.7)
31395-0292	12V dc	4.4	10	2.9 (11)	25 (1.7)
31395-0294	24V dc	2.2	5	2.9 (11)	25 (1.7)
31295-0092	12V dc	3.5	10	1.9 (7)	25 (1.7)
31295-0094	24V dc	1.7	5	1.9 (7)	25 (1.7)

OPERATION

With pump switch off and battery fully charged, fill water tank, open all faucets, then turn pump switch on. Water will begin to flow. When the water is free of air, turn faucets off. Remember,

you are filling the water heater and the toilet and shower lines. When all valves are shut-off, pump will stop. Should pump fail to stop, turn switch off and see the trouble shooting guide.

DIMENSIONAL DRAWING

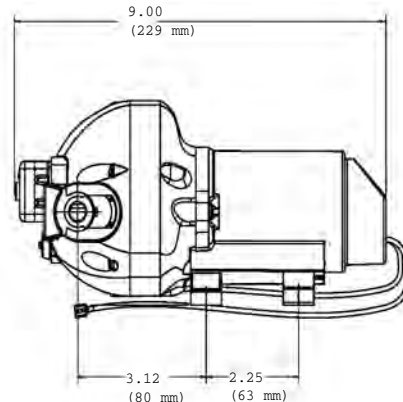
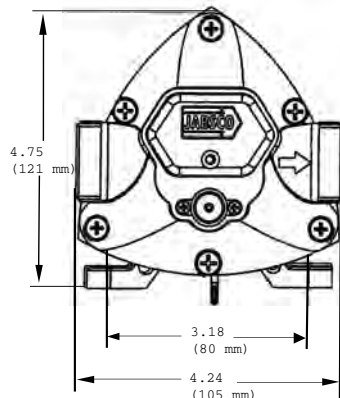

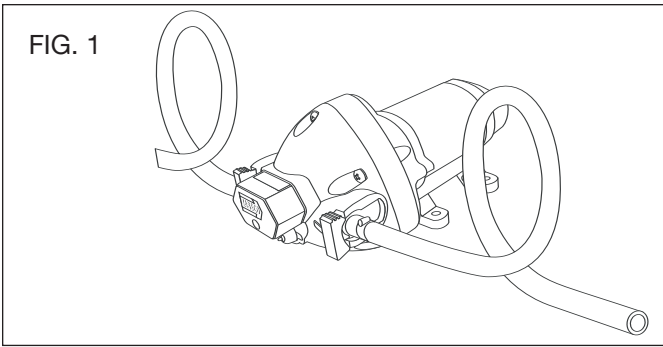

INSTALLATION

STEP 1

Remove shipping plugs from pump ports. There may be slight amount of water that drains out of the pump as all pumps are tested at the factory before shipment.

STEP 2

A direction arrow can be found on the pump head to indicate direction of flow. Connect the appropriate sized hose to one of the supplied fittings and then connect the hose to the water supply tank outlet. To reduce vibration use 1/2" (13 mm) braided or reinforced flexible hose on the inlet and outlet of the pump as shown on Fig.1. Use hose clamps on the slip-on barb connectors.

WIRING (Fig. 3)

IF YOU ARE NOT FAMILIAR WITH APPLICABLE ELECTRICAL STANDARDS, HAVE THE UNIT INSTALLED BY A QUALIFIED ELECTRICIAN.

Suggested wiring information is given as a reference. For proper information, please reference USCG regulations for marine applications and wiring gauges, connectors and fuse protection.

STEP 1

Determine the distance from the power source to the pump and then double the measurement. Wire gauge installation is determined on the entire run length, to the pump and back.

STEP 2

Connect to power supply lead (red)(+) to the positive (+) terminal on the battery or through a properly installed fuse / circuit breaker panel. Then run the length of wire to the pump, connecting the red wire through a switch appropriately rated to the pump's current requirements.

STEP 3

Route the wire so as not to create hazards in operation of the engine, movement of steering components or human traffic.

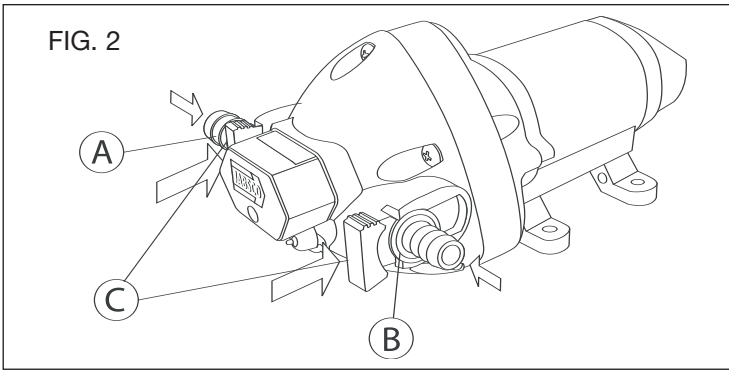

STEP 3

Slide rubber mounts fully into 4 mounting tracks.

STEP 4

Mount pump horizontally in an accessible location or vertically with pumphead down. Support weight of the pump and attach pumphead mounts first then motor mounts second.

STEP 5 (Fig. 2)

Install inlet A and discharge B port connectors. Firmly push slide clips C forward to lock port connectors in place.

STEP 6 (Fig. 4)

Install a Pumpgard™ strainer in an accessible location (for inspection and cleaning) between the tank and pump inlet in order to protect valves from debris.

STEP 4

Connect the red lead to the red lead on the pump housing located pressure switch.

STEP 5

Connect the black lead from the pump to the ground or negative power side (-) of the vessel.

STEP 6

Turn the system off when not in use for extended periods of time or when the water supply tank is empty.

STEP 7

After installation, check voltage at the pump motor. Voltage should be checked when pump is operating. Full voltage must be available at the pump motor at all times for proper pump operation and pump motor life.

WIRE SIZE

Pump Voltage	Total Wire Length - feet (meters)		
	0 - 20 ft (0 - 6 m)	20 - 35 ft (6 - 9 m)	35 - 55 ft (9 - 12 m)
12 VDC	#14 AWG (2.5 mm ²)	#12 AWG (4 mm ²)	#10 AWG (6 mm ²)
24 VDC	#16 AWG (1.5 mm ²)	#14 AWG (2.5 mm ²)	#12 AWG (4 mm ²)

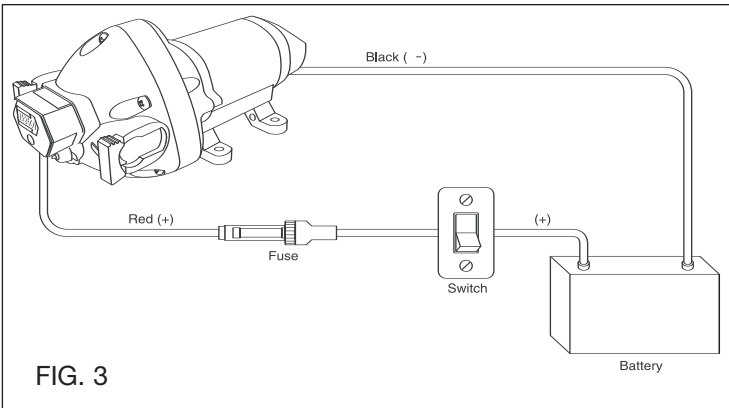

CAUTION Motor case could get hot during extended operation. Prolonged contact with skin may cause a burn.

WARNING Fire hazard. Wiring must comply with applicable electrical standards and include a properly sized fuse or circuit breaker. Improper wiring can cause a fire resulting in injury or death.

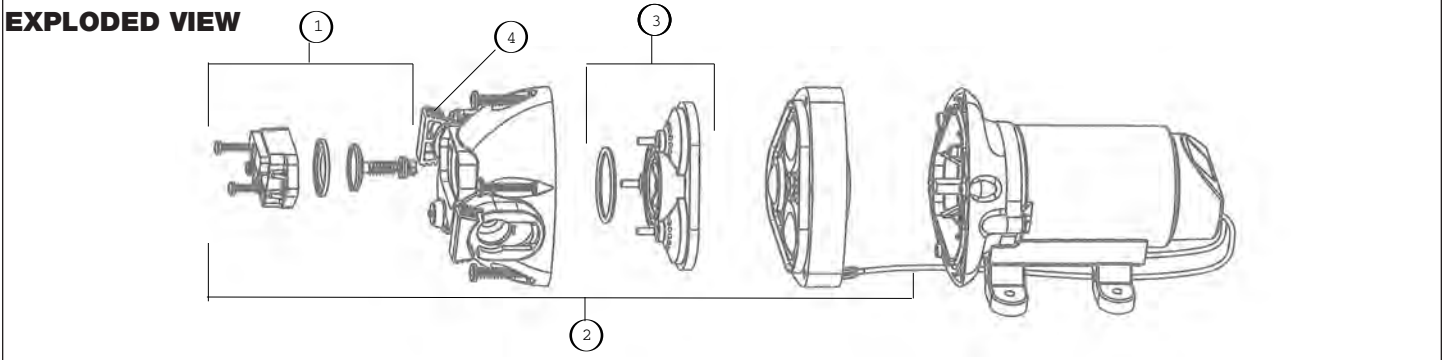
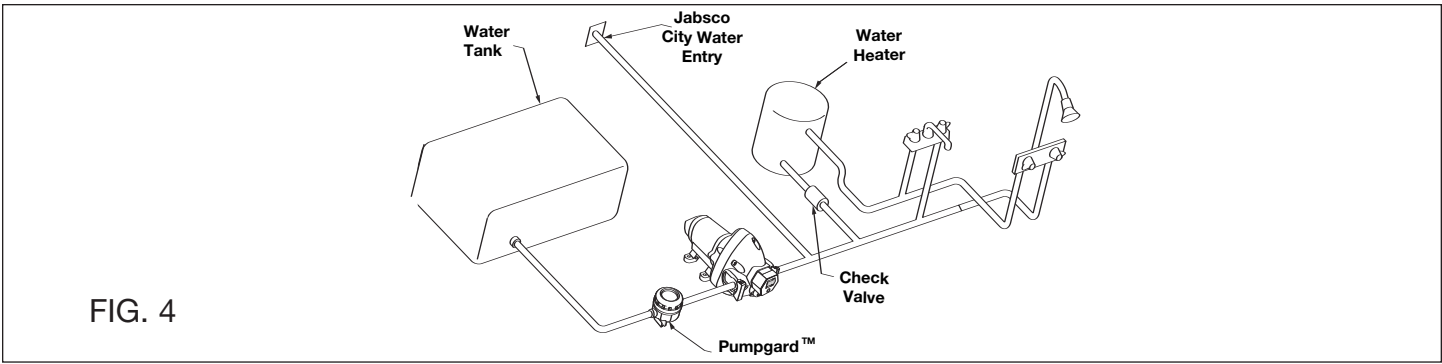

AUTOMATIC WATER SYSTEM PUMP SERVICE PARTS

KEY#	DESCRIPTION	SERIES	
		31395 - XXXX	31295 - XXXX
1	Pressure Switch	(25 psi)	18916-1025
		(40 psi)	18916-1040
		(50 psi)	18916-1050
2	Pumphead Assembly	(25 psi)	18914-1025
		(40 psi)	18914-1040
		(50 psi)	18914-1050
3	Check Valve Assembly	18911-1030	18911-1030
4	Slide Clips (Pair)	30647-1000	30647-1000

**ACCESSORIES
SNAP-IN PORT SYSTEM**

30649-1000 (1 PAIR) SNAP-IN PORT X 1/2" - 14 MALE PIPE STRAIGHT	30654-1000 (1 PAIR) SNAP-IN PORT X 1/2" (13 mm) HOSE BARB STRAIGHT	30653-1000 (1 PAIR) SNAP-IN PORT X 3/4" (19 mm) HOSE BARB STRAIGHT	30650-1000 (1 PAIR) SNAP-IN PORT X GARDEN HOSE STRAIGHT	30655-1000 (1 PAIR) SNAP-IN PORT X 1/2" - 14 MALE PIPE 90° ELBOW	30651-1000 (1 PAIR) SNAP-IN PORT X 1/2" (13 mm) HOSE BARB 90° ELBOW	30642-1000 (1 PAIR) SNAP-IN PORT X 3/4" (19 mm) HOSE BARB 90° ELBOW

Winterizing

Allowing water to freeze in the system may result in damage to the pump and plumbing system. Non-Toxic antifreeze for potable water may be used with Jabsco pumps. Follow manufacturer's recommendations. Refer to boat or equipment manufacturer's instructions for their specific winterizing and drainage procedures. **Do not use automotive antifreeze** to winterize potable water systems. These solutions are highly toxic and may cause serious injury or death if ingested.

1. Drain the water tank. Open tank drain valve. You may use the pump to drain the tank by opening all the faucets in the system. Allow the pump to operate until the tank is empty. Do not operate the pump more than 15 minutes continuously.

- Open all faucets and purge the water from the plumbing system. Turn off power to the pump. Be sure that all the water from the drain lines is drained.
- Remove quick-connect inlet and outlet fittings from the pump and turn the pump on to pump out remaining water from the pump head. Be sure to have a catch pan or a rag under the pump to prevent water from spilling onto the boat. Turn the pump off once the plumbing is empty. Leave the fittings disconnected from the pump until the system is ready to be used again. Make a note on your tank filler that the plumbing is not connected.
- Be sure that all faucets are left open to protect against damage to the plumbing.

Sanitizing

Potable water systems require periodic maintenance to deliver a consistent flow of fresh water. Depending on use and the environment the system is subjected to, sanitizing is recommended prior to storing and before using the water system after a period of storage. Systems with new components, or ones that have been subjected to contamination, should also be disinfected as follows:

(NOTE: The sanitizing procedure is in conformance with the approved procedures of the US Public Health Service.)

1. Use the following methods to determine the amount of common household bleach needed to sanitize the tank:
 - A. Multiply "gallons of tank capacity" by 0.13; the result is the ounces of bleach needed to sanitize the tank (30 gallons X .13 = 3.9 oz bleach).
 - B. Use the number of liters of tank capacity to determine the number of milliliters of bleach needed to sanitize the tank (120 liters of tank capacity = 120 milliliters of bleach).
2. Mix into solution the proper amount of bleach within a container of water
3. Pour the solution (water/bleach) into the tank and fill the tank with potable water.
4. Open all faucets (hot and cold) allowing the water to run until the distinct odor of chlorine is detected.
5. The standard solution must have four (4) hours of contact time to disinfect completely. Doubling the solution concentration allows for contact time of one (1) hour.
6. When the contact time is completed, drain the tank. Refill with potable water and purge the plumbing of all sanitizing solution.

TROUBLESHOOTING

WARNING: BEFORE SERVICING PUMP, TURN OFF PUMP AND DRAIN WATER FROM SYSTEM!!

PROBLEM	SOLUTION
Pulsation Flow - Pump cycles on and off	Restricted pump delivery. Check discharge lines, fittings and valves for undersizing or clogging. Clean screens in faucets. Some filters or purifiers are highly restrictive. Filters/purifiers with high pressure drop may require a separate line and/or the installation of an accumulator tank in the system.
Failure to Prime - Motor operates, but no pump discharge	Restricted intake or discharge line Air leak in intake line Punctured pump diaphragm Debris under flapper valves Crack in pump housing
Pump fails to turn off after all fixtures are closed	Empty water tank Punctured pump diaphragm Discharge line leak Defective pressure switch Insufficient voltage to pump Debris under flapper valves
Low flow and pressure	Air leak at pump intake Accumulation of debris inside pump and plumbing Worn pump bearing (excessive noise) Punctured pump diaphragm Defective motor
Motor fails to turn on	Loose wiring connection Pump circuit has no power Blown fuse/thermal protector tripped Pressure switch failure Defective motor

Jabsco

www.jabsco.com



ITT Industries
Engineered for life

THE PRODUCTS DESCRIBED HEREIN ARE SUBJECT TO THE JABSCO THREE-YEAR LIMITED WARRANTY, WHICH IS AVAILABLE FOR YOUR INSPECTION UPON REQUEST.

U.S.A Jabsco Cape Ann Industrial Park Gloucester, MA 01930 Tel: +1 978 281 0440 Fax: +1 978 283 2619	UK Jabsco Bingley Road, Hoddesdon Hertfordshire EN11 0BU Tel: +44 (0) 1992 450145 Fax: +44 (0) 1992 467132	CANADA Fluid Products Canada 55 Royal Road Guelph, Ontario N1H 1T1 Tel: 519 821 1900 Fax: 519 821 2569	JAPAN NHK Jabsco Company Ltd. 3-21-10, Shin-Yokohama Kohoku-Ku, Yokohama, 222 Tel: +45 475 8906 Fax: +45 475 8908	GERMANY Jabsco GmbH Oststrasse 28 22840 Norderstedt Tel: +49 (40) 53 53 730 Fax: +49 (40) 53 53 7311	ITALY Jabsco Marine Italia Via Tommaseo, 6 20059 Vimercate, Milano Tel: +39 039 685 2323 Fax: +39 039 666 307
---	---	---	--	---	--